



## Literature-Based Research on Antidiabetic Potential of Okra

Dhanish Joseph<sup>1\*</sup>, Hima Davis<sup>2</sup>, Manju Maria Mathews<sup>2</sup>, Bharat Mishra<sup>2</sup> and Junia George<sup>2</sup>

<sup>1</sup>Assistant Professor, Nirmala College of Pharmacy, Muvattupuzha, Kerala, India.

<sup>2</sup>Nirmala College of Pharmacy, Muvattupuzha, Kerala, India.

Received: 12 Jan 2020

Revised: 16 Feb 2020

Accepted: 18 Mar 2020

### \*Address for Correspondence

#### Dhanish Joseph

Assistant Professor,

Nirmala College of Pharmacy,

Muvattupuzha, Kerala, India.

Email: dhanishjoseph707@gmail.com



This is an Open Access Journal / article distributed under the terms of the **Creative Commons Attribution License** (CC BY-NC-ND 3.0) which permits unrestricted use, distribution, and reproduction in any medium, provided the original work is properly cited. All rights reserved.

### ABSTRACT

Diabetes mellitus is an endocrine disorder that affects about 10% of the world population. Management of diabetes without any side effects have been a significant challenge to the medical field since almost all the available allopathic medications have been reported toxic and having side effects. So it is prudent to look for options in herbal medicines which considered to be less toxic and free from side effects than the synthetic ones. Traditional antidiabetic plants can overcome the high cost, side effects of currently available drugs like organ toxicity. This project aims to identify the potential antidiabetic effect of different extracts of okra. *Abelmoschus esculentus* (okra) is a flowering plant belonging to the Mallow family with sufficient hypoglycaemic effect. Several research and review articles discussing the hypoglycaemic effect (both in vivo and in vitro) of okra has collected, and its antidiabetic potential is compared. The results show that the okra can have a glucose reduction in the range of 20 – 70% and the green methanolic okra extract 5mg/kg shows the highest reduction of about 73%.

**Keywords:** Diabetes mellitus, *Abelmoschus esculentus*, Streptozotocin, Alloxan, Phytochemical analysis..

### INTRODUCTION

Diabetes mellitus is a chronic endocrine disorder characterized by impaired insulin secretion or action, which may result in hyperglycemia [1]. Physical inactivity and unhealthy dietary habits result in overweight and insulin resistance which forms the major risk factors for diabetes mellitus [2]. At present, the chronic use of synthetic medicine for the management of diabetes causes severe side effects. Researchers have been looking for alternative therapies that include herbal or natural remedies [3]. Several traditional medicines of herbaceous plants proved to be highly useful in reducing blood glucose levels. Experimental evaluation and isolation of active constituents from



**Dhanish Joseph et al.**

herbal plants having antidiabetic potential is increasing nowadays, which could open up a new era in the field of diabetes management [4].

*Abelmoschus esculentus* (A.E.) commonly known as okra, lady's finger is a flowering plant in the Mallow family with sufficient antidiabetic potential [1]. In this study, the antidiabetic activity of different parts of A.E gathered from the various other studies conducted by different researchers. The work aims to identify multiple in vitro, in vivo research activities conducted about the hypoglycaemic activity of okra and its parts and to identify the real potential of okra in the treatment of diabetes mellitus. The study helps to identify the active constituents present in the different parts of okra which can be used for further research to develop a new safe and effective herbal medicine for the management of diabetes mellitus.

**METHODOLOGY**

Both research and review articles published in peer-reviewed journals have selected which discuss the antidiabetic activity of different parts of *Abelmoschus esculentus*. The sources include Google Scholar, Pubmed, Science direct. The articles taken were published after the year 2010 and then categorized into in vivo and in vitro studies (Table 1 and Table 2). Later the antidiabetic activity was compared and discussed.

**Discussion on *In vivo* antidiabetic studies****Mode of induction**

The most commonly used drug for inducing diabetes found to be alloxan as well as streptozotocin (STZ). The preferable one is STZ due to its effective induction of type II diabetes at a low dose (35 mg/kg), it is also having an advantage of low mortality rate compared to alloxan [15]. Both of these inducing agents have used in different concentrations in various studies (Table 1). The highest dose of alloxan administered intraperitoneally to Wistar rats at 150 mg/kg produces a glucose level in the range of 100 – 170 mg/dl [1, 5]. In contrast, STZ, at a dose of 35 mg/kg, administered intraperitoneally to Sprague Dawley rats produces a glucose level above 200 mg/dl [15].

Similarly, STZ at a dose of 50 mg/kg, when administered intraperitoneally to Sprague Dawley rats produces a glucose level of 100 – 150 mg/dl [8]. From this, it is evident that the STZ is more successful in inducing diabetes comparing with alloxan at lower doses. Those animals induced with STZ at a dose of 35 mg/kg develop a stable blood glucose concentration in two days, i.e. they require a less induction period at low doses as compared to alloxan [15]. At the same time, alloxan injection of dose 150 mg/kg intraperitoneally in Wistar rats gives stable diabetes (150 – 200) for about a month or so [5,1].

**Comparison of extracts**

Ben-Chioma et al. compared the antidiabetic efficiency of aqueous extract and dry powder of okra fruits at a dose of 100 mg/kg in alloxan (65mg/kg) induced Wistar rats. The percentage glucose reduction after 14 days of treatment in aqueous extract and dry powder form of okra fruits found to be 36.08% and 32.36% respectively. The study concluded that increased blood glucose reduction was seen in animals treated with aqueous extract than those given dry powder form [7]. Jain P et al. studied the antidiabetic effect of ethanolic and aqueous okra fruit extract. In alloxan (150 mg/kg) induced Wistar albino rats. Two different doses (250 and 500 mg/kg) of both the extracts compared in a 14 days duration study. The result shows no significant difference in percentage glucose reduction between the ethanolic (21.14% & 20.38%) and aqueous extracts (26.16% & 23.96%) of okra fruit [5]. Kulkarni makes a comparison of the antidiabetic effect between 200 & 400 mg/kg of aqueous extract of dry powder and fresh fruits of okra and okra mucilage in STZ (60 mg/kg) induced adult male Wistar rats for 28 days. The percentage glucose reduction (60 – 70%)



**Dhanish Joseph et al.**

shows that both the aqueous extracts have promising results when compared to the mucilage studied, also the percentage glucose reduction increases with the dose administered in aqueous extracts. But for the two different treatments of mucilage of okra fruit (200 & 400 mg/kg), the percentage glucose reduction remains almost the same (59.80% & 59.60%) [9]. Anjani PP et al. studied the hypoglycaemic efficiency of methanolic green and purple okra extract in two different doses (5 & 10 mg/kg). The study carried out for 14 days in Sprague Dawley rats induced with 50 mg/kg of STZ intraperitoneally. Methanolic extract of green and purple okra at a dose of 5 mg/kg gives a percentage glucose reduction of 73.26% and 72.33% and at a dose of 10 mg/kg provides a percentage with glucose reduction of 66.86% and 37.14% respectively. The study concludes that these two okra extracts show no much difference in percentage blood glucose reduction[8].

An OGTT study of the whole plant of okra has conducted by M.Sarkar et al. in swiss albino mice. The hypoglycaemic effect of crude methanolic extract of the entire plant (200mg/kg), n-Hexane and chloroform soluble fraction isolated from methanolic extract (200 mg/kg) of okra determined in the study. The methanolic extract shows more percentage glucose reduction (46.50%) than the soluble fractions after 3 hours [16]. The comparison of different extracts of okra reveals that the extracted form of okra itself shows some advantages over the other types of okra used in the separate antidiabetic study. However, there was no significant difference in the antidiabetic effect produced by aqueous and alcoholic extracts of okra irrespective of the dose, the animal used, inducing chemical and treatment duration. This study concludes that the antidiabetic activity of okra is similar for various extracts.

**Comparison of Dose of Okra**

The different doses of various extracts of okra compared to see whether there is any difference in antidiabetic activity. A comparison of percentage blood glucose reduction of increasing doses (100, 250, 500 mg/kg) of aqueous extracts of okra fruit in alloxan-induced Wistar rats conducted. The aqueous extract of okra fruit given at a dose of 100 mg/kg has the highest percentage glucose reduction (36.08%) when administered for 14 days [5, 7]. The aqueous and alcoholic extracts (250 & 500 mg/kg) given to alloxan-induced Wistar rats, no much difference in percentage glucose reduction (20 – 25%) was seen [5].

The antidiabetic potential exhibited by different doses of aqueous and alcoholic extracts of okra in STZ induced rats were different. A low dose of alcoholic extract of okra (5, 10 mg/kg) gives a percentage glucose reduction above 50% [8]. A similar percentage glucose reduction obtained for aqueous extracts of okra, when it is administered at a dose of 100 mg/kg or above in STZ induced rats [9, 10]. Different doses of alcoholic extracts can influence the hypoglycaemic activity of okra, but the dose of aqueous extracts is unimportant. This effect also depends on the inducing agent used for diabetes induction. Diabetes induced by STZ can be treated effectively with a low dose of alcoholic extract of okra [8]. In contrast, the glucose reduction in alloxan-induced rats was similar when treated with different doses of both aqueous and alcoholic extracts of okra [5].

**Comparison of Okra with Standard anti-diabetic drug**

The antidiabetic potential of okra in both aqueous and non-aqueous extracts (Figure 1 and Figure 2) has compared with the different standard medicines in various studies [5, 7, 9, 14, 16]. The antidiabetic study of okra fruit conducted by Benchioma et al. in alloxan-induced Wistar rats uses glibenclamide as the standard drug. The percentage glucose reduction by the aqueous extract and dry powder form of okra (100 mg/kg) compared with the standard drug glibenclamide at a dose of 5 mg/kg. The standard drug gives 51.57% glucose reduction, which was higher compared to the aqueous (36.08%) and dry powder (32.36%) forms of okra [7].

Jain p et al. compared the hypoglycaemic efficiency of two different doses (250 & 500 mg/kg) of aqueous and ethanolic extracts of okra fruit with 2.5 mg/kg of standard drug glibenclamide. The results show a higher percentage of glucose reduction by glibenclamide (32.79%) in alloxan-induced Wistar albino rats than the extracts [5]. An OGTT



**Dhanish Joseph et al.**

study of the water-soluble fraction of okra fruit was conducted in alloxan-induced long Evan rats by H. Khatun et al. In this study the aqueous extract (200 mg/kg) of the fruit was compared with 2 mg/kg of metformin, the glucose level reported was  $34.2 \pm 1.07$  mmol/L and  $20.7 \pm 1.01$  mmol/L respectively [14].

The antidiabetic study of different aqueous extracts and mucilage of okra fruit conducted by Kulkarni compared his result with glibenclamide at a dose of 10 mg/kg. The percentage reduction of glucose was 70.94% which was similar to those by the extracts and the mucilage (60 – 70%) of okra [9]. An OGTT study of the whole plant of okra in Swiss albino mice takes 10 mg/kg of glibenclamide as the standard drug. The percentage glucose reduction by the standard was 62.13% which was higher compared to the other groups (40 – 50%) in the study [16]. The most frequently used standard in most of the in vivo antidiabetic studies found to be glibenclamide. The blood glucose reduction was seen in the range of 20 – 70% for different doses of glibenclamide. The comparison of percentage glucose reduction by glibenclamide reveals that the percentage reduction increases as the dose of the drug increases. The study uses 10 mg/kg of glibenclamide gives a percentage reduction of glucose above 60% [9, 16] whereas 51.57% glucose reduction was given when the dose of glibenclamide reduced to 5 mg/kg [7]. Further, when the dose of glibenclamide reduced to 2.5 mg/kg, a further reduction in blood glucose was seen (32.79%) [5].

The methanolic green okra extract showed the highest percentage glucose reduction (73.26%) among all the aqueous and non-aqueous extracts and mucilages at a dose of 5 mg/kg in STZ induced Sprague Dawley rats [8]. The alcoholic extracts of okra fruits show much higher potential in reducing blood glucose levels at lower doses when compared with different doses of aqueous extracts of okra. The above discussion also refers to okra fruit as the best part of the okra plant that is widely used to reduce the blood glucose level. Both the aqueous and non-aqueous extracts of okra fruits studied show promising results [5,7,9,14,15].

**Discussion on In vitro antidiabetic studies**

Apart from the in vivo studies, there are many in vitro studies (Table 2) also carried out in okra fruits and seeds. A.K. Sekar et al. determined the antidiabetic potential of fresh okra fruit by identifying the total phenolic and flavonoid content, % enzyme inhibition and conducting DPPH assay. The results of these in vitro tests are compared between the aqueous, methanolic and ethanolic extracts and showed that methanolic extracts have better activity than the others [12]. V. Sabitha et al. determined the in vitro enzyme inhibitory effect of okra peel and aqueous seed extracts. The aqueous extract of okra seed (80.9%) found to be less potent than the peel extract (88.7%) in reducing blood glucose level since the antidiabetic potential is attributed to the inhibitory effect against glucosidase enzyme. This enzyme retards the carbohydrate digestion, which in turn delays the postprandial rise in glucose level [13]. The hypoglycemic effect of okra fruit studied by measuring glucose adsorption, glucose diffusion and amylase inhibitory activity by Dhiraj et al. The results revealed that the studied vegetable insoluble fibre could effectively adsorb glucose, retard the glucose diffusion and inhibit the  $\alpha$ -amylase activity [3].

**Phytoconstituents responsible for the antidiabetic property of okra**

*Abelmoschus esculentus* is said to exhibit different pharmacological activities like antioxidant, antidiabetic, anti-inflammatory, anticancer, antibacterial properties [17]. Various extracts of okra have been evaluated for their phytochemical composition by different researchers so that the active constituents responsible for the activity or effect can be understood. The biochemical and nutritional evaluation of okra shows that it contains polyphenols, proteins, fat, fibre, carbohydrate and several other antioxidant vitamins [3]. The different parts of okra are rich in various constituents. Fresh fruits contain pectin and mucilage, and the mucilage of fruit is rich in flavonoids. The seeds mainly composed of polyphenols like oligomeric catechins. Ethanolic and aqueous fruit extracts contain carbohydrates, gums and mucilages, proteins, phytosterols, flavonoids, tannins, phenolic compounds, and volatile oil [17, 18]. The antioxidant activity is mainly due to the polyphenols and exhibited by the fruit extracts where the presence of lectin gives anti-inflammatory response shown by the ethanolic extract.



**Dhanish Joseph et al.**

Liao. H analyzed and compared the total phenolic and flavonoid content of okra fruit, flower, leaf and seed methanolic extracts. The results show that the methanolic extract of the flower part has a higher total phenolic and flavonoid content. They also reported a significant correlation between these contents and anti-oxidant activity shown by the plant. In 2012, the same author, isolated a new flavonol glycoside from *Abelmoschus esculentus*, which shows antioxidant property [19, 20]. The chemical analysis of crude and purified okra mucilages resulted that there were a high protein and mineral content in the crude extract compared to the purified one. The ash content was accounted for by calcium, magnesium, potassium and phosphate ions [21].

The hypoglycaemic effect of okra is mainly due to the polysaccharides and different polyphenols present in it [22, 23, and 24]. The flavonoid glycosides like isoquercitrin and quercetin 3-O-gentiobioside reduced blood glucose and serum insulin levels and improved glucose tolerance [23]. Liu et al. purified and identified the dominant polysaccharide of okra, rhamnogalacturonan, as the main chemical responsible for the anti-diabetic effect [25].

**CONCLUSION**

This study aimed to identify the hypoglycaemic effect of okra by review of several reviews and research papers that have been already published and concluded that *Abelmoschus esculentus* is an essential plant that needs to be developed into an anti-diabetic formulation, since, it has high hypoglycaemic property. The different parts of the plant exhibit the activity which is proven by various researchers and the percentage glucose reduction was shown in the range of 20- 70 %. This percentage range was obtained from the articles published in peer-reviewed journals after the year 2010.

The percentage glucose reduction was the main parameter for comparison between the different okra extracts studied by various researchers. The effect of the extract, dose, mode of induction, the period of study on the percentage glucose reduction has been discussed. The phytochemical composition of okra has also been explored to some extent. The flavonol glycosides (quercetin derivatives) and the polysaccharides found in okra were the primary class of phytoconstituents responsible for its antidiabetic activity. The various parts of okra are rich in different bioactive constituents responsible for different therapeutic activities. The phytochemical analysis of okra also reveals the abundance of polyphenols present in it which is responsible for the antioxidant property of okra. The best of all the compared extracts was the green methanolic okra fruit extract at a dose of 5 mg/kg, which shows the highest percentage glucose reduction (73.26%). The best drug for diabetic induction found to be STZ. It can induce diabetes at a low dose and have a low mortality rate compared to alloxan [9, 10, and 15]. The comparison of okra extract activity with the standard drug glibenclamide results that both have similar activity.

*Abelmoschus esculentus* is an important herbal plant that needs to be commercialized within no time as it has high antidiabetic potential. Since it is a commonly available plant and the whole plant exhibiting activity, the drug developed from this could have the advantages of the least adverse effects and affordability. Further studies need to be done on various extracts as well as parts of okra that its safety needs to be explored. The more toxicity studies like histopathology and biochemical evaluations could help to confirm that okra is safe to use in humans and the development of a formulation would be a significant achievement in the management of diabetes.

**REFERENCES**

1. Onuoha N, Iroegbu L, Uwaezuoke N. Anti-diabetic effects of okra [*Abelmoschus esculentus* (L.) Moench] fruits in alloxan-induced diabetic rats. *Biochemistry*. 2017;29(2).
2. Prasad SK, Kulshreshtha A, Qureshi TN. Antidiabetic activity of some herbal plants in streptozotocin-induced diabetic albino rats. *Pak J Nutr*. 2009;8(5):551-7.



**Dhanish Joseph et al.**

3. Amin IM. Nutritional properties of *Abelmoschus esculentus* as a remedy to manage diabetes mellitus: a literature review. International Conference on Biomedical Engineering and Technology 2011 (Vol. 11, pp. 50-54). Singapore: IACSIT Press.
4. Chaimum-aom N, Chomko S, Talubmook C. Toxicology and Oral glucose Tolerance Test (OGTT) of Thai Medicinal Plant Used for Diabetes controls, *Phyllanthus acidus* L.(EUPHORBIACEAE). Pharmacognosy Journal. 2017;9 (1).
5. Jain P, Parkhe G, Jain N, Jain R. Antidiabetic potential of *Abelmoschus esculentus* Linn. In alloxan-induced diabetic rats.
6. Gohil DD, Lele SS. Insoluble Vegetable Fiber as a Potential Functional Ingredient: Invitro Studies on Hypoglycemic and Hypocholesterolemic Effect. American Journal of Food Science and Technology. 2014; 2(2):48-52.
7. Ben-Chioma AE, Tamuno-Emine DG, Dan DB. The effect of *Abelmoschus esculentus* in alloxan-induced diabetic Wistar rats. International Journal of Science and Research; 4 (11): 540. 2015; 543.
8. Anjani PP, Damayanthi E, Rimbawan R, Handharyani E. Potential of okra (*Abelmoschus esculentus* L.) extract to reduce blood glucose and malondialdehyde (MDA) liver in streptozotocin-induced diabetic rats. JurnalGizidanPangan. 2018 28; 13(1):47-54.
9. Kulkarni K. Phytochemical and pharmacological evaluation of *Abelmoschus esculentus* (Lady's Finger) extracts for antidiabetic activity.
10. Tian ZH, Miao FT, Zhang X, Wang QH, Lei N, Guo LC. The therapeutic effect of okra extract on gestational diabetes mellitus rats induced by streptozotocin. Asian Pacific journal of tropical medicine. 2015; 8(12):1038-42.
11. Dubey P, Mishra S. Effect of okra seed in the treatment of hypoglycemia: A research framework using STZ induced rat. Journal of Medicinal Plants. 2018; 6(3):85-8.
12. Ahmed BT, Kumar SA. Antioxidant and Antidiabetic properties of *Abelmoschus esculentus* extract-an in vitro assay. Research Journal of Biotechnology. 2016 1;11(3).
13. Sabitha V, Panneerselvam K, Ramachandran S. In vitro  $\alpha$ -glucosidase and  $\alpha$ -amylase enzyme inhibitory effects in aqueous extracts of *Abelmoschus esculentus* (L.) Moench. Asian Pacific journal of tropical biomedicine. 2012 1; 2(1): S162-4.
14. Khatun H, Rahman A, Biswas M, Islam AU. Water-soluble fraction of *Abelmoschus esculentus* L interacts with glucose and metformin hydrochloride and alters their absorption kinetics after coadministration in rats. ISRN Pharmaceutics. 2011 11; 2011.
15. Peng CH, Lin HC, Lin CL, Wang CJ, Huang CN. *Abelmoschus esculentus* subfractions improved nephropathy with regulating dipeptidyl peptidase-4 and type 1 glucagon-like peptide receptor in type 2 diabetic rats. Journal of food and drug analysis. 2019 1; 27(1):135-44.
16. Mda H, Sarkarb AM. Evaluation of biological activities of *Abelmoschus esculentus* (Malvaceae). Int J curr Sci. 2014; 10: 43-9.
17. Islam MT. Phytochemical information and pharmacological activities of Okra (*Abelmoschus esculentus*): A literature-based review. Phytotherapy research. 2019; 33(1):72-80.
18. Arapitsas P. Identification and quantification of polyphenolic compounds from okra seeds and skins. Food Chemistry. 2008 15; 110(4):1041-5.
19. Liao H, Dong W, Shi X, Liu H, Yuan K. Analysis and comparison of the active components and antioxidant activities of extracts from *Abelmoschus esculentus* L. Pharmacognosy magazine. 2012; 8 (30):156.
20. Liao H, Liu H, Yuan K. A new flavonol glycoside from the *Abelmoschus esculentus* Linn. Pharmacognosy Magazine. 2018; 8(29):12.
21. Woolfe ML, Chaplin MF, Otchere G. Studies on the mucilages extracted from okra fruits (*Hibiscus esculentus* L.) and baobab leaves (*Adansoniadigitata* L.). Journal of the Science of Food and Agriculture. 1977; 28(6):519-29.
22. Doreddula SK, Bonam SR, Gaddam DP, Desu BS, Ramarao N, Pandey V. Phytochemical analysis, antioxidant, antistress, and nootropic activities of aqueous and methanolic seed extracts of ladies finger (*Abelmoschus esculentus* L.) in mice. The Scientific World Journal. 2014; 2014.





## Dhanish Joseph et al.

23. Sindhu RK, Puri V. Phytochemical, nutritional and pharmacological evidences for *Abelmoschus esculentus* (L.). J Phytopharmacol. 2016;5(6):238-41.
24. Durazzo A, Lucarini M, Novellino E, Souto EB, Daliu P, Santini A. *Abelmoschus esculentus* (L.): Bioactive Components' Beneficial Properties—Focused on Antidiabetic Role—For Sustainable Health Applications. Molecules. 2019; 24(1):38.
25. Liu, J.; Zhao, Y.; Wu, Q.; John, A.; Jiang, Y.; Yang, J.; Liu, H.; Yanga, B. Structure characterization of polysaccharides in vegetable "okra" and evaluation of the hypoglycemic activity. Food Chem. 2018, 242, 211– 216.

**Table 1: In vivo Antidiabetic Studies of *Abelmoschus Esculentus***

Plant part	Animal/ Induction method	Treatment Duration	Extraction method	Dose	In vivo response		Reference
					Glucose level	% Reduction	
Fruits	Alloxan 65mg/kg i.v, Wistar rats	14 days	Aqueous	100mg/kg	10.15 ± 3.04 mmol/l	36.08%	Ben-Chioma AE et al, 2015[7]
			Dry powder	100mg/kg	10.74 ± 2.17 mmol/l	32.36%	
			Glibenclamide	5mg/kg	7.69 ± 1.81 mmol/l	51.57%	
			NA	DC	15.88±2.84 mmol/l	-	
			NA	Control	4.57 ± 0.32 mmol/l	-	
Fruits	Alloxan 150mg/kg,i.p, Wistar rats	14 days	Paste	1250mg/kg	163±49.5 mg/dl	44.42%	Onuoha N et al, 2017[1]
				2500mg/kg	98.8 ± 22.6 mg/dl	66.31%	
				5000mg/kg	65.0 ± 22.9 mg/dl	77.83%	
			NA	DC	293.3±43.4 mg/dl	-	
Fruits	Alloxan 150mg/kg BW i.p, Wistar albino rats	14 days	Ethanol 90%w/v	250 mg/kg	114.6±0.61 mg/dl	21.14%	Jain P et al, 2017[5]
				500 mg/kg	107.3±3.16 mg/dl	26.16%	
			Aqueous	250mg/kg	115.7±0.56 mg/dl	20.38%	
				500mg/kg	110.5±1.23 mg/dl	23.96%	
			Glibenclamide	2.5mg/kg	97.67±0.56 mg/dl	32.79%	
			NA	DC	145.33 mg/dl	-	
			NA	Control	100.7±0.76 mg/dl	-	

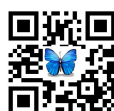



Dhanish Joseph et al.

Table 1: continues

Plant part	Animal/ Induction method	Treatment Duration	Extraction method	Dose	In vivo response		Reference
					Glucose level	% Reduction	
WSF of fruits	Long Evans rats, alloxan (120 mg/kg), i.v, OGTT	24 hrs	Aqueous	200 mg/kg	34.2±1.07 mmol/L	-	H Khatun et al, 2011[14]
			Metformin	2 mg/kg	20.7±1.01 mmol/L	-	
			NA	control	6.8±0.13mmol/L	-	
Fruits	Adult male Wistar rats,STZ 60mg/kg i.p	28 days	Aqueous extract of dry powder	200mg/kg	187 ± 8mg/dl	60.04%	Kulkarni,2017 [9]
				400mg/kg	154 ± 13 mg/dl	67.09%	
			Aqueous extract of fresh fruits	200mg/kg	198 ± 1 mg/dl	57.69%	
				400mg/kg	173 ± 13 mg/dl	63.03%	
			Mucilage	200mg/kg	188 ± 9 mg/dl	59.80%	
				400mg/kg	189 ± 8 mg/dl	59.60%	
			Glibenclamide	10mg/kg	136 ± 6 mg/dl	70.94%	
NA	DC	468+9 mg/dl	-				
NA	Control	78 ± 2 mg/dl	-				
Fresh fruits	male Sprague-Dawley rats 8 rats /group 35mg/kg STZ	12 weeks	Ethanollic	0.45mg/kg	209.33±46.05 mg/dl	52.98%	Huang CN et al, 2018[15]
			NA	DC	445.25+23.45 mg/dl	-	
			NA	Control	77.25+2.95 mg/dl	-	

Table 1: continues

Plant part	Animal/ Induction method	Treatment Duration	Extraction method	Dose	In vivo response		Reference
					Glucose level	% Reduction	
Okra extract	45mg/kg STZ ,i.p, SD rats	19 days	Aqueous extract	200 mg/kg	6.87 ± 0.49mmol/l	29.89%	Tian ZH et al, 2015[10]
			NA	DC	9.80 ± 1.02 mmol/l	-	
			NA	Control	6.67 ± 0.88 mmol/l	-	
Okra green	STZ 50 mg/kg	14 days	Methanolic Green okra	5mg/kg	100.25 ± 8.32mg/dl	73.26%	Anjani PP et al, 2018[8]







**Dhanish Joseph et al.**

Purple without separating between skin and seeds	BW i.p, Sprague Dawley rats		extract	10mg/kg	124.25 ±34.26 mg/dl	66.86%	
			Methanolic Purple okra extract	5mg/kg	103.75 ± 7.09 mg/dl	72.33%	
				10mg/kg	145 ± 58.43 mg/dl	37.14%	
			NA	DC	375+70.60 mg/dl	-	
			NA	Control	82.75 ± 5.39 mg/dl	-	
Seeds	STZ 60mg/kg BW i.p,male Wistar rats	42 days	Powdered	250mg	180.3±6.2 mg/dl	22.38%	Dubey P et al, 2018[11]
				500mg	168.6±7.0 mg/dl	27.42%	
			NA	DC	232.3 mg/dl	-	
			NA	Control	99.5±4.4 mg/dl	-	
Whole plant	Swiss albino mice, OGTT studies	3 hrs	n-Hexane soluble fraction	200mg/kg	-	40.32%	M. Sarkar et al, 2014[16]
			Chloroform soluble fraction	200mg/kg	-	35.57%	
			Crude methanolic extract	200mg/kg	-	46.50%	
			Glibenclamide	10mg/kg	-	62.13%	

**Table 2: in vitro Antidiabetic Studies of *Abelmoschus esculentus***

SI No	Plant Part	Invitro Assay	Result			References
1	Fresh Fruit		Aqueous	Methanolic	Ethanolic	A.K. Sekar et al, 2016[12]
		Total phenolic content	113.5mg/g	159.7mg/g	155.5mg/g	
		Total flavonoid	17.2mg/100g	26.3mg/100g	23.9mg/100g	
		DPPH assay	79.30%	90.50%	94.50%	
		Enzymatic inhibitory %	84.40%	92.30%	88.60%	
2	Peel and seed	Alpha-amylase	Aqueous peel powder	Aqueous seed powder		V.Sabitha et al,2012 [13]
			87.57±0.35%	80.06±0.2%		
3	Fruit	Alpha-glucosidase	88.7±0.2%	80.9±0.9%		Dhiraj D.G et al, 2014 [4]
		Glucose adsorption capacity	7.40mmol/g			
		Glucose dialysis retardation index	4.90±0.010			
		Glucose diffusion	553.72±0.61µmol			
		Amylase inhibitory activity	7.84±1.19%			





Dhanish Joseph et al.

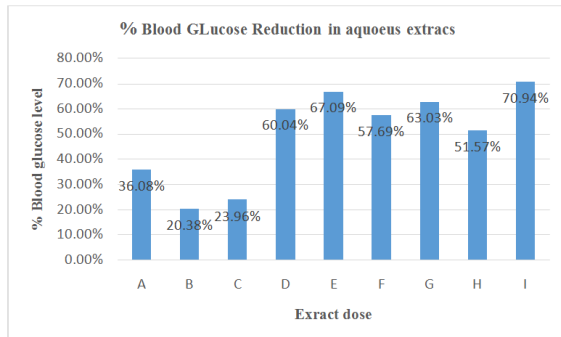

Figure: 1 Percentage of blood glucose reduction of aqueous extracts of okra fruit

A= aqueous extract 100mg/kg, B= aqueous extract 250mg/kg, C= aqueous extract 500mg/kg, D= aq. extract of dry powder 200mg/kg, E= aq. extract of dry powder 400mg/kg, F= aq. extract of fresh fruit 200mg/kg, G= aq. extract of fresh fruit 400mg/kg, H= Glibenclamide 5mg/kg, I= Glibenclamide 10mg/kg

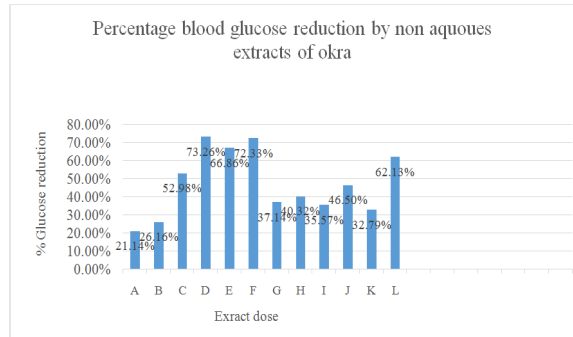

Figure: 2 Percentage Blood Glucose Reduction by Non Aqueous extracts of okra

A= ethanolic extract 250mg/kg, B= ethanolic extract 500mg/kg, C= ethanolic extract 0.45mg/kg, D= methanolic green okra extract 5mg/kg, E= methanolic green okra extract 10mg/kg, F= methanolic purple okra extract 5mg/kg, G= methanolic purple okra extract 10mg/kg, H= n-hexane soluble fraction 200mg/kg, I= chloroform soluble fraction 200mg/kg, J= crude methanolic extract 200mg/kg, K= glibenclamide 2.5 mg/kg, L= glibenclamide 10mg/kg

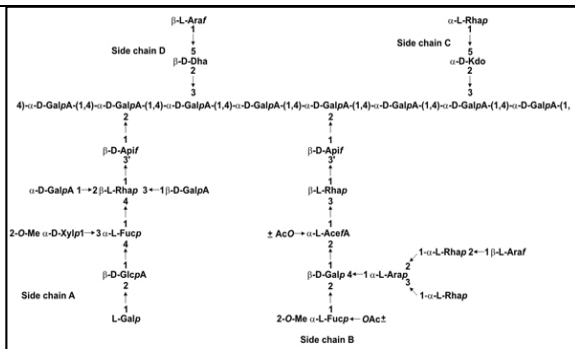

Figure :3. Rhamnogalacturan

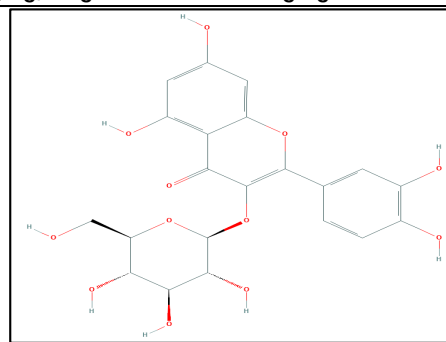

Figure :4. Quercetin 3- O - gentiobioside





## Trends of Liquidity Management and their Impact on Financial Performance of CIPLA and SUN PHARMA

Pramod Kumar Patjoshi<sup>1\*</sup> and Girija Nandini<sup>2</sup>

<sup>1</sup>Associate Professor, School of Management, Centurion University of Technology and Management, Bhubaneswar, Odisha, India

<sup>2</sup>Assistant Professor, School of Management, Centurion University of Technology and Management, Bhubaneswar, Odisha, India

Received: 14 Jan 2020

Revised: 17 Feb 2020

Accepted: 19 Mar 2020

### \* Address for Correspondence

#### Pramod Kumar Patjoshi

Associate Professor,  
School of Management,  
Centurion University of Technology and Management,  
Bhubaneswar, Odisha, India.  
Email: pramodpatjoshi@gmail.com



This is an Open Access Journal / article distributed under the terms of the **Creative Commons Attribution License** (CC BY-NC-ND 3.0) which permits unrestricted use, distribution, and reproduction in any medium, provided the original work is properly cited. All rights reserved.

### ABSTRACT

A corporate sector in order to remain in the competitive business environment should safeguard its suitable liquidity. Equally, a corporate sector displeases if it cannot be able to meet its short term responsibility eventually of time significances in wicked creditworthiness by outsiders, a decrease in the value of reputation in the market. Bearing in mind the inflexible opposition that happens in the current commercial atmosphere, analyzing liquidity and examines of its effect on profitability is extremely important to the business managers to quick policy-making capability and advantage. A study of liquidity risk management is important for internal as well as external users of financial information. Liquidity should be neither extreme nor insufficient. Liquidity is the monetary strength of a company. In this background, an effort has been made to analyze the liquidity management and financial performance of CIPLA Ltd. (CIPLA) and Sun Pharmaceutical Industries Ltd. (SUN PHARMA), leading pharmaceutical industries in India for the period from 2009-10 to 2018-19. To investigate the trends of liquidity management and their impact on financial performance of CIPLA and SUN PHARMA different financial ratio analysis, comprehensive rank test, Spearman's Rank correlation analysis, and t-test have been employed.

**Keywords:** Liquidity Management, Financial Performance, Correlation, t test and Profitability Ratios.





**Pramod Kumar Patjoshi and Girija Nandini**

## INTRODUCTION

Liquidity talks about the obtainability of cash or cash equivalents to meet the current obligations and short-term operating requirements. In other arguments, liquidity is the volume of liquid assets that are accessible to pay the current obligations as well as revenue expenditure in addition to the short term debt (accountingcourse.com). Liquidity means having adequate money in the form of cash, or near-cash assets, to meet the financial requirements. Proper liquidity and investment management help in planning the outflows to creditors on time to avoid losing name, trust and potential insolvency (Panigrahi, 2013). Financial performance is the result of a firm's strategies and operations in monetary value, which use to reflect in the firm's return on growth, value-added, return on equity and investment, etc. (businessdictionary.com). Liquidity and profitability have great significance for the companies. Liquidity shows the controlling of current assets and current liabilities in a company. It displays whether a firm can effectively manage its short term obligations or not (Megaladevi, 2018).

Liquidity risk is high when the company is not able to pay its current obligations. If a firm wants to sustain for a long period it should remain liquid and meet its current liabilities when due. Despite the companies give importance on capital budgeting and capital structure, the recent trend is that a lot of firms focus on assets management potency. Liquidity management involves investments in liquid assets to meet the short-term maturing debt of creditors and others. Different stockholders like shareholders, Investors, money lenders, and managers look to the financial statements of the companies by means of financial ratios related to liquidity measurement for evaluating liquidity hazard. This is generally done by comparing short term assets as well as short term liabilities to determine whether the company can make additional investments, disbursement of dividend as well as bonuses or, encounter their debt requirements. Companies that have high leverage than their liquidity risk is so high since they have fewer assets to impose. Consequently, the company should take numerous steps to decrease the gap between its current assets to overcome their debt requirements (investopedia.com).

Liquidity management shows a vital role in a company's profitability, risk and also its value. Investment in more risky projects can give more return. So, the firms want to keep more liquidity may have low risk and low profitability. A firm with low liquidity may have high-risk outcomes to high profitability. So the company should try to balance the risk and return. Van Horne and Wachowicz (2004) defined that too many current assets may have a negative impact on a firm's profitability, while a low current asset possibly will lead to a decrease in liquidity and stock-outs, which can create problems in managing the business. When all the present obligations are met, it increases the credit standing of the organization. But, failure to satisfy such obligations on a continuous basis would reduce the credit standing and market name leading to difficulties in finding sources of finance. A study of liquidity management is important for internal as well as external users of financial information. Liquidity should be neither extreme nor insufficient. Liquidity is the monetary strength of a company. It can be analyzed by computing different liquidity ratios and can rank them as per the Mootal's final Rank check (Vimala & Kumar, 2016).

Financial management policy follows to maintain suitable liquidity in order to maintain its current accountabilities and also profitability. Competition is very high in the current commercial atmosphere, so measuring liquidity and analyses of its effect on financial performance are extremely significant to the business managers to quick decision-making ability and superiority. The universal increase of privatization and liberalization, which was originally exposed in the U.K. in the 1980s and later extended over almost all over the world, has inspired significant debate in India on the prudence of liberalization. The growing requirement on the universal financing institutions is increasing in the adverse situation in India has also carried the appeal to approve the economic liberalization approach by the Government of India. The Indian Government expected to adopt a new economic business strategy. Later, many approach announcements visible by the Indian Government have thrust on the way to deregulation, globalization, and liberalization. Accordingly, a large number of public enterprises had grown-up speedily over the few decades in an almost non-competitive situation have in progress of facing top opposition. So, a notable change in



**Pramod Kumar Patjoshi and Girija Nandini**

the Indian public sector has similarly developed inevitably to face the new competitions (Jafar & Sur, 2006). In this context, the current study has been made to analyze the liquidity management and financial performance of CIPLA Ltd. (CIPLA) and Sun Pharmaceutical Industries Ltd. (SUN PHARMA), leading pharmaceutical industries in India for the period from 2009-10 to 2018-19.

**Brief Profile of CIPLA**

CIPLA is a pharmaceutical and biotechnology company in India. It is a multinational company and one of the world's biggest producers of generic medicines. It was established by Dr. Khwaja Abdul Hamiedas with the name The Chemical, Industrial & Pharmaceutical Laboratories in 1935. It has its center of operations and offices in Mumbai, Maharashtra, Belgium, UK, and the United States. Its present chairman is Dr. Yusuf K. Hamied. CIPLA has 34 production centers in India that are cGMP compliant and follow national and main international standards. Its medicines are traded in more than 170 countries including the United States, Canada, Europe, Africa, Australasia, Latin America, and the Middle East. The company's production includes more than 2000 different types of products like multiple therapeutic categories, which include treatment for critical, prolonged and unusual diseases. The corporation produces reasonable drugs and it has a pioneering role in the HIV/AIDS cure. It is amongst the important producers of ARV (anti-retroviral) medicines in all over the world, and was the world's first pharmaceutical concern (in 2001) to supply ARVs to nations at less than a dollar a day. In the financial year 2014-15 (according to company sources), its ARV drugs were used by more than 2 million HIV patients in 100 countries (www.brandindiapharma.in).

**Brief Profile of SUN PHARMA**

Sun Pharmaceuticals Ltd. is the largest (by market capitalization) pharmaceuticals company in India and the 5th largest generic medicinal corporation in the world. The company produces and sells superior quality, reasonable drugs in more than 150 countries and 6 continents. By means of 31st March 2015, Sun Pharma had knowledgeable human resources of more than 2,000 scientists and had capitalized over 7% of its yearly incomes in Research & Development. The company has over 48 production facilities all over the world. 30 brands of the company are within the top 300 pharma brands in India. SUN PHARMA Company sells its medicines as branded generics in India and also in all the major global markets. The healing sections covered by the corporation's more than 2000 different types of medicines including psychiatry, anti-infective, neurology, cardiology, orthopedics, diabology, gastroenterology, ophthalmology, nephrology, urology, dermatology, gynecology, respiratory, oncology, dental and Nutritional. SUN PHARMA is mainly divided into four parts. They are Active Pharmaceutical Ingredients (API), International Branded Generics, Indian Branded Generics, and US Generics. Similarly, they make domain APIs which include steroids, hormones, peptides, and anti-cancer medicines. All these medicines are manufactured at 14 international standard manufacturing facilities all over the world. More than 72% of the company's revenues are from international markets. One of the largest markets of the company remains in the USA that consists of nearly 60% of its revenue (www.brandindiapharma.in).

**Literature Review**

Elijelly (2004) studied the liquidity gain trade-off: associate in a rising market. It examined the relationship between gain and liquidity, as calculated by current magnitude relation and money gap (cash conversion cycle) for the joint-stock firms in Saudi Arabia. The study shows a negative relation between the firm's gain and its liquidity level. Sharma and Kumar (2011) studied that the positive relationship amongst accounts receivables and profitability is because of the situation that Indian corporations have to uphold added trade credit to survive with their international participants. While Kartik (2012) reveals trends in liquidity management and their impact on profit. A linear relationship between liquidity and profit is found by using a multivariate analysis model. Here the companies are keeping an adequate quantity of current liabilities for liquidity management. On the other hand, Panigrahi (2013)



**Pramod Kumar Patjoshi and Girija Nandini**

examined leading Indian cement firms that have been taken to find the liquidity position. Ten years data viz, 2000-2001 to 2009-2010 have been taken for the analysis. Only secondary data is taken for the study. Statistical techniques like mean, variance, constant of variation, magnitude relation analysis, and Motaal's final rank check has been used. It shows that the liquidity position of small firms is higher as compared to big firms. It also indicates an unsound liquidity position. Low or negative assets indicate the aggressive assets management policy of the companies.

Further in the study Egbide, et al. (2013) analysed the association between liquidity and profitability. They have selected 30 different production companies listed on the Nigeria Stock Exchange for 5 years which is from 2006 to 2010. The outcome recommends that the current ratio and liquid ratio are positively connected with profitability. But the cash conversion period is negatively related with the profitability of production companies in Nigeria. The relationship in all the cases was statistically insignificant, representing low degree of impact on liquidity and the profitability of those companies. So, the inclusive state of liquidity should be better by creating more accurate credit policy which would produce smaller cash conversion period (CCP) and have a positive influence on the profitability of the company. Similarly Venkateswarlu and Reddy (2015) analysed the liquidity management of cement corporations for a period of ten years from 2003-04 to 2012-13. Current quantitative relations, fast quantitative relation, liquid funds to current assets quantitative relation and comparative liquidity position have been taken for the analysis. Motala's final Rank is also taken to rank the companies. They found that Deccan Cements Ltd. is in the first rank, representing the prime liquid company amongst the six sample corporations. Panyam Cements & Mineral Industries Ltd. and Sagar Cements Ltd. are in second and third positions. Anjani Portland Cements Ltd. was in the fourth rank and Bheema Cements Ltd. and NCL Industries Ltd. got fifth rank and sixth rank, showing the notable critical liquidity position. Whereas Vimala and Kumar (2016) reveals the liquidity management of major pharmaceutical companies by applying statistical techniques like variance, coefficient of variation and found liquidity should be neither more nor less. Here the liquidity is analyzed by computing different liquidity ratios and Motala's final Rank check. Patjoshi (2016) studied the impact as well as the relationship of liquidity on the profitability of selected steel companies in India from 2010-11 to 2014-15. The collected data has investigated through the descriptive analysis, correlation and regression of various financial ratios for finding out the impact of liquidity on profitability.

On the contrary Waswa et al. (2018) investigated how the performance of the company influenced by the liquidity management. They have taken five sugar companies for the period of 30th June 2005 to 2016 for the study. They suggest that a negative relationship occurs between liquidity management and firm performance by using a random-effects regression model. The analysis proposes that cautious thought and forecasting of funding liquidity management are important ways to increase the financial performance of the company. The study also recommends that there is a necessity for the sugar manufacturing companies to enhance their operating cash flow, to influence their financial performance positively. While Megaladevi (2018) investigated the interrelationship of liquidity and profitability in different Cement Corporations in India by applying different financial ratios for profitability and financial ratios of liquidity risk management. The outcomes of the analysis display that CR and QR are having a significant association with ROAE. ROE is correlated at a 5% level of significance with ICR and at a 1% level of significance with ROCE and EBDITCE. ROTA is positively correlated at a 5% level of significance with ROCE, EBDITCE, ROACE, and ICR Profitability ratios also play a significant role in the financial positions of companies. All stakeholders have curiosity to know the liquidity position of a firm. The Suppliers of firm will check the liquidity of the firm before supplying goods on credit. ROCE is having a significant relationship with ROE, ROTA, EBDITCE, ROAE, ROACE, TDDR and ICR at 5% and 1% level of significance. The research shows that Liquidity and profitability have near association amongst every ratio. Patjoshi (2018) examined the analysis of liquidity management and financial performance of ONGC and IOCL from 2006–2007 to 2015–2016 and to examine the liquidity and trend of the degree of relationship among liquidity as well as profitability different financial ratios, inclusive rank test, Spearman's Rank correlation analysis, and t-test applied.



**Pramod Kumar Patjoshi and Girija Nandini****Objectives of the Study**

This study has the following core objectives:

1. To study the trends of liquidity management and financial performance of CIPLA Ltd. (CIPLA) and Sun Pharmaceutical Industries Ltd. (SUN PHARMA).
2. To analyse the impact of liquidity management on financial performance of CIPLA and SUN PHARMA.

**Hypothesis of the Study**

Keeping the objectives in view, the hypothesis framed for the study is Hypothesis (Ho): There is no significant difference between liquidity management on financial performance of CIPLA and SUN PHARMA.

**METHODOLOGY OF THE STUDY**

To study the trends of liquidity management and their impact on financial performance of CIPLA and SUN PHARMA, data has been composed from the published annual reports of the CIPLA and SUN PHARMA for the ten years from 2009-10 to 2018-19. The collected data have been appropriately re-arranged, classified and tabulated as per the requirements of the study. Various financial ratios, comprehensive rank tests, Spearman's rank correlation analysis, and t-test have been employed to study the liquidity management and financial performance of the CIPLA and SUN PHARMA. To find out the liquidity management of the CIPLA and SUN PHARMA throughout the study period, the significant liquidity ratios like Current Ratio (CR), Liquid Ratio (LR), Inventory Turnover Ratio (ITR), and Debtor Turnover Ratio (DTR) have been calculated. For a comprehensive rank test with liquidity ratios, the profitability ratio Return on Total Assets (ROTA) has also been applied.

**RESULTS AND DISCUSSION****Analysis of Important Ratios related to Liquidity of CIPLA and SUN PHARMA**

Table-1 defines the movement of the liquidity position of CIPLA and SUN PHARMA through significant selected ratios related to liquidity and the trend of the significant ratios connected to liquidity has elaborated below. Current Ratio is a liquidity ratio that measures a company's capacity to pay short-term liabilities or those due within one year. It communicates investors and analysts how a company can increase the current assets to fulfill its current debt and other short-term obligations. High CR indicates more funds to meet the company's short term liabilities. Table 1 shows that the Current ratio of CIPLA and SUN PHARMA has decreased significantly from 2009-10 to 2018-19. The current ratio of CIPLA varies from 2.20 to 3.33 and SUN PHARMA varies from 2.44 to 4.46. The average current ratio of CIPLA and SUN PHARMA are 2.71 and 3.31 respectively, for the study period, which is more than the standard ratio of 2:1.

Similarly, Liquid ratio (LR) is also known as acid test ratio or quick ratio. It measures the detailed liquidity position of companies. The liquid ratio is calculated to overcome the limitation of the current ratio. The liquid ratio is the association between quick assets and quick liabilities. Normally a higher liquid ratio is taken as a good liquidity position of the companies and a lower liquid ratio says that the liquidity position of the companies is not good. Table-1 shows that the liquid ratio of the CIPLA and SUN PHARMA varies from 1.26 to 2.05 and from 2.00 to 3.24 respectively. The averages LR of both the companies for the study period were 1.57 and 2.62. It specifies that CIPLA and SUN PHARMA liquid ratios are higher than the standard ratio of 1:1. Both the companies authenticate a declining trend for the study period. The average liquid ratio is also more than the standard ratio of 1:1 for the period 2009-10 to 2018-19.



**Pramod Kumar Patjoshi and Girija Nandini**

Inventory turnover ratio (ITR) is the number of times a company sells its finished goods and replaces its stock of goods in a period of time. It shows how the company manages its inventory and how their sales plans are effective. More inventory turnover ratio is healthier for the company. It implies a company is able to sell its goods very fast and so also demand for their product is also very high. Low inventory turnover specifies fewer sales and low demand for the products of a company. The inventory turnover ratio describes whether a company is managing its stock appropriately or not. The ITR of CIPLA varies from 3.03 times to 4.20 times and that of SUN PHARMA varies from 3.69 times to 5.21 times. The averages ITR of CIPLA and SUN PHARMA were 3.66 times and 4.26 times respectively for a period of 2009-10 to 2018-19. The average inventory turnover ratio was 2.12 times for Indian Manufacturing Companies as per a study conducted by CMIE (CMIE, 1998, P.7). The ITR of both companies is higher than the standard set by CMIE during the study period. Thus, it showed efficient management of inventory for both the companies. However, SUN PHARMA has managed its inventory more efficiently as compare to CIPLA during the study period.

Debtors Turnover Ratio (DTR) is also known as the Receivables Turnover Ratio. It defines how quickly the credit sales of the company are changed into cash. This ratio displays the competence of a firm in handling and collecting the credit delivered to the customers. Debtor management is also one of the important parts of working capital management. The high debtor turnover ratio shows the high liquidity of debtors. Low debtors turnover ratio and long collection period imply that payment by debtors is delayed. Table-1 shows that the minimum Debtors Turnover Ratio as 3.62 times and maximum DTR as 6.23 times for CIPLA. SUN PHARMA shows the minimum DTR as 3.27 times and maximum DTR as 7.40 times. The average debtor turnover ratio of Indian Manufacturing Companies should be 11 times as per the study done by CMIE (CMIE, 1998, P. 7). The average debtor turnover ratios of CIPLA are 4.97 times and SUN PHARMA is 4.45 times for the year 2009-10 to 2018-19. It is significantly lower than the standard set by CMIE. So, CIPLA and SUN PHARMA have not made their management of debtors correctly.

Table-1, also defines that both the companies CIPLA and SUN PHARMA liquidity position has been declined considerably from 2009-10 to 2018-19. The evaluation of different liquidity ratios between CIPLA and SUN PHARMA displays that the liquidity position of SUN PHARMA is mostly better than CIPLA. From the above, it is clear that the liquidity positions of CIPLA and SUN PHARMA were satisfactory. Both the companies implemented a conservative approach for liquidity management as both the companies have maintained higher liquidity ratios (CR & LR) as compared to the standard liquidity ratio. SUN PHARMA was more conservative than CIPLA for the study period. But both the companies are very poor in managing their debtors.

**Analysis of Ranking in order of liquidity of CIPLA and SUN PHARMA**

To measure the comprehensive liquidity position of CIPLA and SUN PHARMA more accurately, a complete test has been taken into consideration. Different ratios (expressed as a percentage) like Inventory to current assets ratio, Debtor to current assets ratio, Cash & Bank to current assets ratio and Other current assets to current assets ratio have been taken into consideration for the assessment. Accordingly, a procedure of ranking has been used to work out at an additional inclusive degree of liquidity in which the above stated four ratios are combined in a points score. A high score describes a reasonably beneficial position and ranking has been assessed correspondingly. But, a low inventory to current assets ratio gives a more beneficial position and accordingly ranking has appraised respectively. The final ranking has been done on the norm that lower the points scored the better are the liquidity position and vice versa.

Table 2 shows that the liquidity position of the CIPLA is best during the study period i.e. in the years 2009-10 & 2018-19. The year 2017-18 is in the second position followed by the years 2016-17, 2010-11 & 2011-12, 2015-16, 2012-13, 2014-15 and 2013-14 correspondingly in that order. So, the disparity in the liquidity position under different years of the study period can be a point for analysis into the financial performance of the CIPLA. Table 3 shows that the liquidity position of the SUN PHARMA is best during the study period i.e. in the year 2013-14. The year 2016-17





**Pramod Kumar Patjoshi and Girija Nandini**

stood the second position followed by the years 2014-15, 2017-18, 2015-16, 2018-19, 2011-12 and 2009-10, 2010-11 & 2012-13 correspondingly in that order. It reveals that the comprehensive liquidity position of SUN PHARMA in the second half of the study period was better as compared to that in the first half. So, the difference in the liquidity position in different years of the study period can be a point for analysis into the financial performance of the SUN PHARMA.

**Analysis of Spearman's Rank Correlation between Liquidity and return on total assets (ROTA) of CIPLA**

Table 4 displays the study of the overall profitability of CIPLA and calculates the t-test between liquidity and return on total assets (ROTA). It also shows the degree of association among liquidity and profitability of CIPLA by using Spearman's rank correlation coefficient. Here the composite ranks of liquidity (as given in Table 2) and the ranks of profitability (ROTA) have been taken for the analysis. It is observed from Table 4 that the company's ROTA decreased significantly over the study period 2009-10 to 2018-19. The average ROTA is 12.99% during the study period. The variation is from 6.93% to 19.07%. The computed t value is 1.83 and P-value is 0.50. It is found that there is no significant difference between liquidity and profitability at 5 percent level. Therefore the null hypothesis (there is no significant difference between liquidity management on financial performance of CIPLA) is accepted. The table shows that the rank correlation coefficient between liquidity and ROTA is -0.52; there was a negative correlation between liquidity and profitability of CIPLA throughout the study period. So, CIPLA cannot able to manage its liquidity in an efficient manner so as to safeguard its liquidity position and incapable to achieve higher profitability combination.

**Analysis of Spearman's Rank Correlation between Liquidity and return on total assets (ROTA) of SUN PHARMA**

Table 5 shows the analysis of the overall profitability of SUN PHARMA and the t-test between liquidity and return on total assets (ROTA). It also tried to assess the degree of association among liquidity and profitability of SUN PHARMA by using Spearman's rank correlation coefficient. Here the composite ranks of liquidity (as given in Table 3) and the ranks of profitability (ROTA) have been taken for the analysis.

Table 5 depicts return on total assets, t-test and P-value of SUN PHARMA over the study period. ROTA of SUN PHARMA has dropped significantly over the study period. The average ROTA is 21.55% during the study period. The variation is from 0.05% to 37.43%. The calculated t value 1.83 and P-value of 0.50 which was found that there is no significant difference between liquidity and profitability at 5% level. Therefore the null hypothesis (there is no significant difference between liquidity management on financial performance of SUN PHARMA) is accepted. It shows that the rank correlation coefficient is -0.60; there was a negative correlation between liquidity and profitability of SUN PHARMA during the study period. Consequently, SUN PHARMA cannot able to manage its liquidity in an efficient manner so as to safeguard its liquidity position and incapable to achieve higher profitability combination.

**CONCLUSION**

A momentous weakening trend to meet the current obligation and immediate debt paying capability of both the sample companies CIPLA and SUN PHARMA was experiential through the study period. Additionally, the capability in managing the liquidity of the companies treaded down particularly by the passage of time throughout the study period. All financial ratios except debtor turnover ratio relating to the liquidity of CIPLA and SUN PHARMA have worsened extremely with the passage of time. All these objectionable appearances have conclusively a contrasting impression on the overall liquidity position of CIPLA and SUN PHARMA. Both the companies



**Pramod Kumar Patjoshi and Girija Nandini**

implemented a conservative approach for liquidity management as both the companies have maintained higher liquidity ratios (CR & LR) as compared to the standard liquidity ratio. SUN PHARMA was more conservative than CIPLA for the study period. But both the companies are very poor at managing their debtors. It does not match the rank correlation coefficient between liquidity and profitability as there was a negative correlation between liquidity and profitability of both the companies CIPLA and SUN PHARMA during the study period. For SUN PHARMA the rank correlation between liquidity and profitability is a highly negative correlation as compare to CIPLA during the study period. An additional distinguished consequence of the study is that the relationships between the foremost liquidity and profitability indicators of the companies during the study period have no significant difference at 5 percent level. Therefore the null hypothesis (there is no significant difference between liquidity management on financial performance of CIPLA and SUN PHARMA) is accepted. It also reveals from the study that the overall profitability of the companies has come down considerably throughout the study period. This mainly due to the fact the companies cannot able to maintain the efficiency of all components of current assets throughout the study period. In the comparison between different liquidity ratios of CIPLA and SUN PHARMA it is clear that the liquidity position of CIPLA is better than SUN PHARMA for the study period. From the analysis, it originates that both the company's return on total assets has also come down suggestively with the decrease in the liquidity position. However, both the companies CIPLA and SUN PHARMA cannot able to manage their liquidity in an efficient manner so as to safeguard its liquidity position and incapable to achieve higher profitability combination for the study period.

**REFERENCES**

- 1) B. C. Egbide, O. Uwuigbe , U. Uwuigbe , "Liquidity Management and Profitability of Manufacturing Companies in Nigeria", IOSR Journal of Business and Management (IOSR-JBM), Vol. 9(1), 2013, pp. 13-21.
- 2) A. Eljelly, "Liquidity-Profitability Tradeoff: An Empirical Investigation in an Emerging Market", International Journal of Commerce and Management, vol. 14(2), 2004, pp. 48-61.
- 3) <http://www.businessdictionary.com/definition/financial-performance.html>
- 4) <https://www.myaccountingcourse.com/accounting-dictionary/liquidity>
- 5) <https://www.brandindiapharma.in/pharmaceutical-companies-india/sun-pharma>
- 6) <https://www.investopedia.com/ask/answers/122714/what-liquidity-management.asp>
- 7) N. C. Kartik, "Trends in liquidity management and their impact on profitability- a case study", Great Lakes Herald ,Vol 6(1), 2012, pp 16-30.
- 8) K. H. I. Madushanka, M. Jathurika, "The Impact of Liquidity Ratios on Profitability (With special reference to Listed Manufacturing Companies in Sri Lanka)", International Research Journal of Advanced Engineering and Science, vol. 3( 4), 2018, pp. 157-161.
- 9) P. Megaladevi, "A Study on The Impact of Liquidity Ratios on the Impact of Liquidity Ratios on Profitability of Selected Cement Companies in India", ICTACT Journal on Management Studies, vol.4(4), 2018, pp. 860-864
- 10) A. Panigrahi, "Liquidity Management of Indian Cement Companies – A Comparative Study", ,IOSR Journal of Business and Management (IOSR-JBM), Vol.14 ( 5), 2013, pp. 49-61.
- 11) P. K. Patjoshi, "A Study on Liquidity Management and Financial Performance Of Selected Steel Companies in India", International Journal of Advanced Information Science and Technology (IJAIST), vol. 5 (7), 2016, pp.108-117.
- 12) P. K. Patjoshi, "Analysing Liquidity Management and Financial Performance Practices of ONGC and IOCL", Siddhant-A Journal of Decision Making, vol.18 (2), 2018, pp. 175-184.
- 13) A. K. Sharma, S. Kumar, "Effect of Working Capital Management on Firm Profitability: Empirical Evidence from India", Global Business Review, vol. 12(1), 2011, pp.159-173.
- 14) K. Smith, "Profitability versus Liquidity Tradeoffs in Working Capital Management, in Readings on the Management of Working Capital", New York, St. Paul: West Publishing Company, 1980.





**Pramod Kumar Patjoshi and Girija Nandini**

- 15) J. C. Van Horne, J. M. Wachowicz, "Fundamentals of Financial Management", (12 ed.), New York: Prentice Hall, 2004.
- 16) P. Venkateswarlu, B. K. Reddy, "Liquidity Management of Select Cement Companies of Andhra Pradesh - (A Comparative Study)", Vol. 3(5), 2015, pp 31-42.
- 17) S. Vimala, J. P Kumar, "Analysis of Liquidity Management of Select Pharmaceutical Companies in India", GJRA-Global Journal for Research Analysis, Vol.5 (12), 2016, ISSN No 2277 , pp.27-29.
- 18) C. W. Waswa, M. S. Mukras & O. David, "Effect of Liquidity on Financial Performance of the Sugar Industry in Kenya", International Journal of Education and Research, vol. 6 (6), 2018 , pp.29-44.

**Table 1 Financial Ratios relating to Liquidity Management of CIPLA and SUN PHARMA**

Year	Current Ratio		Liquid Ratio		Inventory Turnover Ratio		Debtor Turnover Ratio	
	Cipla	Sun Pharma	Cipla	Sun Pharma	Cipla	Sun Pharma	Cipla	Sun Pharma
2009-10	3.13	4.46	2.05	3.24	3.75	3.71	3.62	3.39
2010-11	3.33	3.87	1.96	3.00	3.32	3.90	4.24	5.06
2011-12	2.65	3.54	1.56	2.80	3.79	3.89	4.52	3.91
2012-13	3.07	3.02	1.64	2.39	3.47	4.45	4.96	4.23
2013-14	2.77	2.94	1.38	2.46	3.53	5.21	6.23	7.40
2014-15	2.53	2.44	1.28	2.00	3.03	4.89	5.72	5.22
2015-16	2.20	3.51	1.26	2.88	3.62	4.44	5.85	4.20
2016-17	2.25	3.08	1.37	2.55	4.20	4.62	5.71	4.38
2017-18	2.55	2.85	1.58	2.30	3.76	3.85	4.91	3.39
2018-19	2.59	3.33	1.66	2.55	4.13	3.69	3.94	3.27
Average	2.71	3.31	1.57	2.62	3.66	4.26	4.97	4.45
Minimum	2.20	2.44	1.26	2.00	3.03	3.69	3.62	3.27
Maximum	3.33	4.46	2.05	3.24	4.20	5.21	6.23	7.40

**Table 2 Statement of Ranking in order of liquidity of CIPLA**

Year	Inventory to Current Assets		Debtor to Current Assets		Cash and Bank Balance to Current Assets		Other Current Assets to Current Assets		Total Rank	Ultimate Rank
	%	Rank	%	Rank	%	Rank	%	Rank		
2009-10	34.63%	1	35.87%	2	1.41%	10	28.07%	1	14	1.5
2010-11	41.20%	6	32.22%	5	2.07%	8	24.50%	3	22	5.5
2011-12	41.16%	5	34.57%	3	2.01%	9	22.26%	5	22	5.5
2012-13	46.46%	8	32.48%	4	2.78%	7	18.27%	8	27	8
2013-14	50.30%	10	28.47%	8	3.04%	6	18.19%	9	33	10
2014-15	49.31%	9	26.14%	10	7.36%	3	17.19%	10	32	9
2015-16	42.59%	7	26.36%	9	9.75%	1	21.30%	7	24	7
2016-17	39.21%	4	28.83%	7	7.02%	4	24.94%	2	17	4
2017-18	37.91%	3	29.08%	6	9.05%	2	23.97%	4	15	3
2018-19	35.64%	2	37.31%	1	5.56%	5	21.49%	6	14	1.5

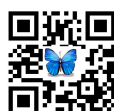



**Pramod Kumar Patjoshi and Girija Nandini**

**Table 3 Statement of Ranking in order of liquidity of SUN PHARMA**

Year	Inventory to Current Assets		Debtor to Current Assets		Cash and Bank Balance to Current Asset		Other Current Assets to Current Assets		Total Rank	Ultimate Rank
	%	Rank	%	Rank	%	Rank	%	Rank		
2009-10	27.38%	10	29.95%	1	11.27%	10	27.18%	6	27	9
2010-11	22.37%	8	17.26%	8	33.11%	6	27.26%	5	27	9
2011-12	20.94%	6	20.86%	5	33.79%	5	24.41%	9	25	7
2012-13	21.03%	7	22.11%	3	33.11%	7	23.76%	10	27	9
2013-14	16.50%	1	11.63%	10	40.10%	1	31.77%	1	13	1
2014-15	17.94%	3	16.82%	9	34.81%	4	30.43%	3	19	3
2015-16	18.01%	4	19.00%	6	36.97%	3	26.01%	8	21	5
2016-17	17.19%	2	18.12%	7	38.10%	2	26.59%	7	18	2
2017-18	19.20%	5	21.80%	4	27.70%	8	31.29%	2	19	4
2018-19	23.51%	9	26.49%	2	21.69%	9	28.31%	4	24	6

**Table 4. Rank Correlation between Liquidity and ROTA of CIPLA**

Year	ROTA (%)	Ranking based on ROTA	Ranking of Liquidity
2009-10	19.07%	1	1.5
2010-11	15.29%	4	5.5
2011-12	16.26%	3	5.5
2012-13	18.73%	2	8
2013-14	13.86%	5	10
2014-15	10.95%	6	9
2015-16	10.12%	7	7
2016-17	6.93%	10	4
2017-18	9.29%	9	3
2018-19	9.44%	8	1.5
Average	12.99%		
Minimum	6.93%		
Maximum	19.07%		

Spearman's rank Correlation coefficient Between liquidity and ROTA is -0.18 and t value is 1.83. P value is 0.50 being insignificant difference at 5% level

**Table 5 Rank Correlation between Liquidity and ROTA of SUN PHARMA**

Year	ROTA (%)	Ranking based on ROTA	Ranking of Liquidity
2009-10	33.83%	2	9
2010-11	32.81%	3	9
2011-12	37.43%	1	7
2012-13	30.25%	4	9
2013-14	23.83%	5	1
2014-15	0.05%	10	3
2015-16	15.95%	7	5
2016-17	22.02%	6	2
2017-18	8.26%	9	4
2018-19	11.04%	8	6
Average	21.55%		
Minimum	0.05%		
Maximum	37.43%		

Spearman's rank Correlation coefficient Between liquidity and ROTA is -0.60 And t value is 1.83. P value is 0.50 being insignificant difference at 5% level





## Spectrum of Simple Graph and Connectivity

F.Doujan Wrikat

Faculty of Science, Department of Mathematics, Mutah University, Jordan

Received: 11 Jan 2020

Revised: 15 Feb 2020

Accepted: 19 Mar 2020

### \*Address for Correspondence

**F.Doujan Wrikat**

Faculty of Science,

Department of Mathematics,

Mutah University, Jordan.

Email: fawwari@gmail.com, fawri@mutah.edu.jo



This is an Open Access Journal / article distributed under the terms of the **Creative Commons Attribution License** (CC BY-NC-ND 3.0) which permits unrestricted use, distribution, and reproduction in any medium, provided the original work is properly cited. All rights reserved.

### ABSTRACT

Let  $\Gamma$  be a simple graph, the vertex connectivity of  $\Gamma$  is the minimum number of vertices whose removal cause a disconnected or trivial graph. In general vertex connectivity called connectivity of the graph  $\Gamma$ .

The spectrum of  $\Gamma$  consists of the eigenvalues together with their multiplicities of the adjacency matrix of the graph  $\Gamma$ .

In this article, we will investigate and construct a relation between graph spectrum and connectivity of certain types of simple graphs.

**Keywords** : Graph, connectivity, matrix, spectrum.

## INTRODUCTION

There are several reasons for the interest in the theory of graph spectrum. It has many applications in engineering fields and many branches of mathematics. The theory of graph spectrum can be considered as a method of using linear algebra as a tool in graph theory and its applications. Now we will present some basic definitions which will be used in the sequel.

**Definition 1.1:** A graph  $\Gamma$  in an unordered triple  $(V(\Gamma), E(\Gamma), R)$ ; where  $V(\Gamma)$  in a nonempty set of  $\Gamma$  an unordered pair of vertices.

**Definition 1.2:** A graph  $\Gamma$  in called simple graph if its undirected graph with no loops and no parallel edges.

**Definition 1.3:** The valency of a vertex  $v$  in  $\Gamma$  is the number of edges incident with it.

**Definition 1.4:** A graph  $\Gamma$  is called  $k$ -regulars if valancy of  $v$  equal  $k$  for all  $v$  in  $\Gamma$ .





### Doujan Wrikat

**Definition 1.5:** A graph  $\Gamma$  with  $n$  vertices is called a complete graph if every vertex of  $\Gamma$  adjacent with rest vertices in  $\Gamma$ , denoted by  $K_n$ .

**Definition 1.6:** A complete bigraph  $K_{m,n}$  is a graph with two disjoint sets of vertices and every vertex in the first set adjacent with all vertices in the second set.

**Definition 1.7:** A star graph  $(S(1,n))$  is a tree consists of one root and  $n$  end vertices.

**Definition 1.8:** A graph  $\Gamma$  is connected if there exists at least one path between any two distinct vertices in  $\Gamma$ .

**Definition 1.9:** The vertex connectivity of a graph  $\Gamma$  is the minimum number vertices whose removal cause a disconnected or trivial graph and its denoted by  $VC(\Gamma)$ .

**Definition 1.10:** The adjacency matrix  $A(\Gamma) = A = [a_{ij}]$  of a labeled graph  $\Gamma$  with  $n$  vertices is an  $n \times n$  matrix  $a_{ij} = 1$ , if  $v_i$  adjacent with  $v_j$  and  $0$ , otherwise.

**Definition 1.11:** The determinant of the matrix  $(\lambda I - A(\Gamma))$  is called the characteristic polynomial of the graph  $\Gamma$ , denoted by  $P(\lambda) = a_0 \lambda^n + a_1 \lambda^{(n-1)} + \dots + a_n$

**Definition 1.12:** The eigenvalue of  $A(\Gamma)$  are the roots of  $P(\lambda)$ .

**Definition 1.13:** The spectrum of the graph  $\Gamma$  consists of the eigenvalues of  $A(\Gamma)$  with their multiplicities, denoted by  $\text{spec}(\Gamma)$ .

## SPECTRUM OF SIMPLE GRAPHS

Now we will introduce some basic results which will be used in the sequel.

**Theorem 2.1 (Kolman.B.[4]):** All the roots of the characteristic polynomial of a real symmetric matrix are real numbers.

**Theorem 2.2 (Biggs.N.[1]):** Let  $\Gamma$  be a  $k$ -regular graph. Then:

- 1)  $k$  is an eigenvalue of  $\Gamma$ .
- 2)  $\Gamma$  is connected, if the multiplicity of  $k$  is one.
- 3) For any eigenvalue  $\lambda$  of  $\Gamma$ .  $|\lambda| \leq k$ .

**Theorem 2.3 (Biggs.N.[1]):** Let  $\Gamma$  be connected graph with  $n$  vertices and diameter  $d$ . Then  $\Gamma$  has at least  $d + 1$ , and at most  $n$  distinct eigenvalues.

**Theorem 2.4 (Cvetkovic.D.[2]):** Let  $\Gamma$  be a connected graph with  $m$  distinct eigenvalues. Then diameter of  $\Gamma \leq m-1$ .

**Theorem 2.5 (Cvetkovic.D.[2]):** Let  $\Gamma$  be a connected  $k$ -regular graph with  $n$  vertices, let  $\lambda$  be a simple eigenvalue of  $\Gamma$ . Then

- 1)  $\lambda = k$ , if  $n$  is odd.
- 2)  $\lambda = 2q - k$ , if  $n$  is even,  $q \in \{0, 1, \dots, K\}$ .

**Theorem 2.6 (Biggs.N.[1]):** Let  $\Gamma$  be a  $k$ -regular graph with  $n$  vertices, let  $P(\lambda) = \lambda^n + a_1 \lambda^{n-1} + \dots + a_n$ . Then, the following hold:

- 1)  $a_1 = 0$
- 2)  $a_2 = -E(\Gamma)$





**Doujan Wrikat**

3) –  $a_3/2$  = Number of  $K_3$  in  $\Gamma$ .

**Theorem 2.7 (Kassasbeh.S.[5]):** Let  $P_n$  be a path graph. Then

$$\text{Spec}(P_n) = \begin{pmatrix} 0 & \sqrt{n}-2 & -\sqrt{n}-2 \\ n-2 & 1 & 1 \end{pmatrix} =$$

**Theorem 2.8 (Wrikat.F.[6]):** Let  $\Gamma$  be a complete graph with  $n$  vertices. Then

$$\text{Spec}(K_n) = \begin{pmatrix} n-1 & -1 \\ 1 & n-1 \end{pmatrix}$$

**Theorem 2.9 (Wrikat.F.[6]):** Let  $\Gamma$  be a bipartite graph with  $m + n$  vertices. Then

$$\text{Spec}(K_{m,n}) = \begin{pmatrix} \sqrt{mn} & 0 & -\sqrt{mn} \\ 1 & m+n-2 & 1 \end{pmatrix}$$

**Theorem 2.10:** Let  $\Gamma$  be a star graph with  $n+1$  vertices,  $S(1,n)$ . Then

$$\text{Spec}(S(1,n)) = \begin{pmatrix} \sqrt{n} & 0 & -\sqrt{n} \\ 1 & n-1 & 1 \end{pmatrix}$$

**Proof:** Let  $\Gamma$  be a star graph  $S(1,n)$ .

Since  $S(1,n)$  isomorphic to  $K_{1,n}$ . So by previous theorem the result holds.

**SPECTRUM OF GRAPHS AND CONNECTIVITY**

In the following sequel we will introduce and construct relation between spectrum of graphs and vertex connectivity of certain types of simple graphs.

**Theorem 3.1 (Fielder.M.[3]):**

- 1) VC (Disconnected graph) = 0
- 2) VC (Graph with cut-vertex) = 1
- 3) VC ( $K_n$ ) =  $n-1$

**Theorem 3.2:** Let  $\Gamma$  be a simple graph. Then

- 1) The vertex connectivity of  $K_{m,n}$  is minimum ( $m,n$ )
- 2) The vertex connectivity of  $S(1,n)$  is 1
- 3) The vertex connectivity of  $P_n$  is 1
- 4) The vertex connectivity of  $C_n$  is 2
- 5) The vertex connectivity of  $k$ -regular is  $K$

**Proof:**

- 1) Let  $\Gamma$  be a bipartite graph  $K_{m,n}$ , so  $\Gamma$  consist of two disjoint set of vertices, the vertices in the first set have valences  $n$ , and in the second have valence  $m$ , thus removing the min ( $m,n$ ) disconnect the graph  $\Gamma$ .
- 2) Let  $\Gamma$  be a star graph  $S(1,n)$ , so the root vertex is a cut vertex. Hence removing the root cause a disconnect graph.
- 3) Let  $\Gamma$  be a path graph  $P_n$ , since  $P_n$  have  $n-2$  cut vertices. Then  $VC(P_n) = 1$
- 4) Let  $\Gamma$  be a cycle graph  $C_n$ . Then removing any two nonadjacent vertices disconnect the graph  $\Gamma$ .
- 5) Let  $\Gamma$  be a  $k$ -regular graph, since the minimum valency in  $\Gamma$  is  $K$ , so removing  $K$  vertices disconnect  $\Gamma$ .





### Doujan Wrikat

**Theorem 3.3** (Fielder.M[3]): For any graph  $\Gamma$ .  $VC(\Gamma) = \text{minimum valancy in } \Gamma$ .

**Theorem 3.4** (Fielder.M[3]): Let  $\Gamma$  be a  $k$ -regular graph with  $n$  vertices. Then  $\text{Spec}(\Gamma) = \{\lambda_1, \lambda_2, \dots, \lambda_n\}$ , then  $\lambda_1 = k$ .

**Theorem 3.5** : Let  $\Gamma$  be a  $k$ -regular graph with  $n$  vertices. Then  $VC(\Gamma) \leq \lambda_1$ .

**Proof:** Let  $\Gamma$  be a  $k$ -regular graph,  $|V(\Gamma)| = n$ . So  $\text{Spec}(\Gamma) = \{\lambda_1, \lambda_2, \dots, \lambda_n\}$ ,  $\lambda_1 \geq \lambda_2 \geq \dots \geq \lambda_n$ . and since maximum valancy equal  $\lambda_1 = k$ . Thus  $VC(\Gamma) = \lambda_1$ .

**Theorem 3.6:** Let  $\Gamma$  be a complete graph  $K_n$ , and let  $\text{Spec}(\Gamma) = \{\lambda_1, \lambda_2, \dots, \lambda_n\}$  Then  $VC(\Gamma) = \lambda_1$ ,  $\lambda_1 \geq \lambda_2 \geq \dots \geq \lambda_n$ .

**Proof:** Let  $\Gamma$  be a complete graph  $K_n$ , since  $\text{Spec}(K_n) = \left( \begin{matrix} n-1 & -1 \\ 1 & n-1 \end{matrix} \right)$ , and  $K_n$  is  $(n-1)$ -regular, so  $K_n$  is  $n-1 = \lambda_1$ .

**Theorem 3.7:** Let  $\Gamma$  be a bigraph  $K_{m,n}$ , let  $\{\lambda_1, \lambda_2, \dots, \lambda_n\}$  be the eigenvalue of  $\Gamma$ , where  $\lambda_1 \geq \lambda_2 \geq \dots \geq \lambda_n$ . Then  $VC(\Gamma) \leq \lambda_1$ .

**Proof:** Let  $\Gamma$  be a bigraph  $K_{m,n}$ , since  $\text{Spec}(K_{m,n}) = \left( \begin{matrix} \sqrt{mn} & 0 & -\sqrt{mn} \\ 1 & m+n-2 & 1 \end{matrix} \right)$ , so maximum eigenvalue is  $\sqrt{mn} = \lambda_1$ , and since  $\sqrt{mn} \geq \text{minimum}(m,n)$ . so  $VC(K_{m,n}) \leq \lambda_1$ .

## REFERENCES

1. Norman Biggs, Algebraic Graph Theory, Cambridge University Press Cambridge (1997).
2. D.M. Cvetkovic, M.Doop, H,Sachs, Spectra of Graphs, Theory and application, Academic press (1978).
3. M.Filder.M.Algebraic Connectivity of Graphs, Czecholovak Mathematical Journal, (1973), Vol,23, p 298.
4. B.Kolman, Elementary Linear Algebra, Macmillan press, (1982).
5. Saba Kassarba, The Characteristic Polynomials of Graphs, Thesis,(2008), (Unpublished).
6. F.D.Wrikat, Spectra of Graphs, Ph.d, Thesis, East Anglia University,UK,(1992).







## Comparative Study of Age and Growth in Some Common Edible Freshwater Fishes of Odisha by using Scale

Abhilash Pattnaik, Siba Prasad Parida, Soumen Mohanty and Pradip Kumar Prusty\*

Department of Zoology, School of Applied Sciences, Centurion University of Technology and Management, Bhubaneswar, Odisha, India

Received: 14 Jan 2020

Revised: 16 Feb 2020

Accepted: 19 Mar 2020

### \*Address for Correspondence

#### Pradip Kumar Prusty

Department of Zoology,  
School of Applied Sciences,  
Centurion University of Technology and Management,  
Bhubaneswar, Odisha, India.  
Email: pradipkumar.prusty@cutm.ac.in



This is an Open Access Journal / article distributed under the terms of the **Creative Commons Attribution License** (CC BY-NC-ND 3.0) which permits unrestricted use, distribution, and reproduction in any medium, provided the original work is properly cited. All rights reserved.

### ABSTRACT

The age of Indian major carp *Catla catla*, minor carp *Cirrihinus reba* and snakehead *Ophiocephalus striatus* was determined by scale analysis method. Different length parameters were measured and length-weight comparison was also done. Scale analysis method was found to be the most suitable method for estimating age. Growth rate of *Catla catla* was found to be faster than that of *Cirrihinus reba*. The age group was divided as 0+ and 1+ for below 1yr of age and more than 1yr of age respectively. No significant variation was seen, rather the samples were found similar with each other. No adverse environmental impact was found on any species. The intra-specific and inter-specific correlation and ANOVA results indicate a +ve relationship among the species.

**Keywords:** age determination, scale, *Catla catla*, *Cirrihinus reba*, *Ophiocephalus striatus*.

### INTRODUCTION

Age determination of fish provides vital information on sexual maturity, spawning time, catchable size, growth rate and lifespan (Ujjania, 2012). These parameters are very essential in fishery. There are four main methods of determining age and growth in fishes: i. Peterson's method of length-frequency analysis, ii. Analysis of scale and other hard parts, iii. Rearing of fish in captivity and observing their growth rate along with analysis of scale, otolith etc., iv. Tagging live fishes in their natural condition after noting essential data and re-examine those fishes after particular interval to observe the changes (Seshappa, 1999). However the last method is not that much easy as only few tagged fishes get recovered. Scale analysis is mostly preferred because it is affordable and quick (Das, 2012). Scales can be used without sacrificing the fish. Therefore, this study is highly significant for fishery management and conservation



**Abhilash Pattnaik et al.**

(Bhatt, 2018). In case of trees, age can be estimated by counting the annual rings in the cross section of trunk. Similarly counting the number of annuli of fish scale provides its age. These annuli or lines of growth usually develop once a year. Age and growth studies are essential in understanding the dynamics of fish population and annual variation. It also represents the effect of various biotic and abiotic factors on the organism (Mayank, 2015).

*Catla catla* (Hamilton, 1822) is the fastest growing carp species (Mitra, 1942). *Cirrihinus reba* (Hamilton, 1822) is a common Indian minor carp like *Labeo bata*. *Ophiocephalus striatus* (Bloch, 1793) is also called as snakehead which is highly rich in nutrients. All these three freshwater fishes have high consumer preference. Several authors have studied on the age and growth of fish on the basis of scale analysis. Johal and Tandon have concluded that the riverine *Catla catla* have better growth rate than those of reservoirs. Prakash and Gupta have studied the growth rate in all the three major carp species and found out that their growth rate is faster during the first five years of life and then becomes slower. The present study is based on estimating the age and growth rate in *Catla catla*, *Cirrihinus reba* and *Ophiocephalus striatus* which will be helpful in various fishery aspects.

## MATERIALS AND METHODS

Freshwater fishes *Catla catla*, *Cirrihinus reba* and *Ophiocephalus striatus* were collected from the local areas of Bhubaneswar from October 2019 to February 2020. All the experiments were done inside the laboratory of Department of Zoology, Centurion University of Technology and Management, Bhubaneswar. Measurements were taken with the help of a measuring tape. Weight and sex were also recorded. Scales from each fish were removed from the region below the dorsal fin and above the lateral line. 10-12 scales were taken from each fish and kept separated. Isolated scales were washed in tap water and scrubbed gently between fingertips to remove mucus and dust particles. Then they were dried on a tissue paper. To make scales more clear and soft, they were kept inside the weak solution of KOH for 5mins; then again washed with tap water and dried. Scales were then placed in 30%, 50% and 70% alcohol for about 5mins to dehydrate. After that they were stained with Eosin and washed with 70% alcohol to remove excess stain. Again the scales were dehydrated with 90% alcohol for 5mins. Finally the scales were placed over slide, covered with cover slip and observed under compound microscope (10x). The number of complete annuli or rings were counted and noted down properly.

## RESULTS

*Catla catla*, *Cirrihinus reba* and *Ophiocephalus striatus* (n=5) samples were collected having the mean length of 38.86±3.61cm, 34.18±1.98cm and 39.9±3.55cm respectively. Besides the total length, other measurements were also noted down such as: the fork length, standard length, head length, pre-pelvic length, pre-dorsal length, dorsal fin base length, caudal peduncle length, body depth, peduncle depth, pre-orbital length, eye diameter, post-orbital length, pectoral length, pelvic fin base length and anal fin base length. All the morphometric data were tabulated. Then the mean and standard deviation of each parameter were calculated. The mean weight of *Catla catla* samples was 686gm, *Cirrihinus reba* was 446gm and *Ophiocephalus striatus* was 762gm. The male-female ratio was 2:3 in *Catla catla*, 1:4 in *Cirrihinus reba* and 2:3 in *Ophiocephalus striatus*. One of the *Catla catla* females and both the *Ophiocephalus striatus* males were found to be more than 1yr of age but all the *Cirrihinus reba* samples were below 1yr age.

## DISCUSSION

The scales of all these three species are cycloid. Focus, radii, true ring and false ring were distinguished properly. Circuli were very clearer. The age group was categorized as 0+ for below 1yr age and 1+ for more than 1yr of age. One *Catla catla* sample and two *Ophiocephalus striatus* samples showed 1 complete ring formation on their scales. So they were placed under 1+ age group. Those samples which didn't show any annual ring formation were placed under 0+ age group. Under 0+ age group, *Catla catla* showed better growth rate than *Cirrihinus reba* which justifies that *Catla*



**Abhilash Pattnaik et al.**

*catla* is the fastest growing carp species (Mitra, 1942). From the correlation table it can be seen that there is no significant deviation among the samples. It indicates that there is no adverse environmental effect on them. From ANOVA it was observed that in all the three species, the degree of freedom (df) between groups is 4 and within groups is 75. The value of p between groups is 0.97 in *Catla catla*, 0.99 in *Cirrihinus reba* and 0.97 in *Ophiocephalus striatus*. Similarly the value of F between groups is 0.12 in *Catla catla*, 0.05 in *Cirrihinus reba* and 0.13 in *Ophiocephalus striatus*.

**CONCLUSION**

The results indicate that all the samples were in good health condition and showed optimum growth in their habitat. They were found to be devoid of any adverse environmental effect. It can be concluded that the scale analysis method is the simplest method for estimation of age in fishes. The correlation and ANOVA results indicate the +ve relationship among the species. The present findings on age and growth analysis will be useful in fishery management.

**ACKNOWLEDGEMENTS**

The authors are thankful to the faculties of the Department of Zoology, Centurion University of Technology and Management, Bhubaneswar, Odisha for providing necessary facilities for the project.

**REFERENCES**

1. Bhatt NA, Tank PR, Kavindra J and Sharma BK, 2018. Age, growth and harvestable size of *Catlacatla* (Ham) from Khodiyar dam, Dhari, Gujarat, JEZS, 6(2):623-628.
2. Das SP, Bej D, Swain S, Jena JK and Das P, 2012. Relative age and growth of Indian major carp *Cirrihinusmrigala* from peninsular rivers of India, J Aqua, 20:35-43.
3. Deepak PK, Sarkar UK, Negi RS and Paul SK, 2008. Age and growth profile of Indian major carp *Catlacatla* from rivers of Northern India, ActaZool Sin, 54:136-143.
4. Jhingran VG, 1952. General length-weight relationship of three major carps of India, InstSci India (B), 18(5):449-460.
5. Johal MS and Tandon KK, 1992. Age and growth of the carp *Catlacatla*(Hamilton, 1822) from the northern India, Fish Res, 14:83-90.
6. Khan MA and Khan S, 2009. Comparison of age estimates from scale, opercular bone, otolith, vertebrae and dorsal fin ray in *Labeorohita*, *Catlacatla* and *Channamarulius*, Fish Res, 100:255-259.
7. Lee RM, 1920. A review of the methods of age and growth determination in fishes by means of scales, Fish Invest LondSer II, 4:2-32.
8. Mayank P, Tyagi RK and Dwivedi AC, 2015. Studies on age, growth and age composition of commercially important fish species, *Cirrihinusmrigala* (Hamilton, 1822) from the tributary of the Ganga River, India, Euro J Exp Bio, 5(2):16-21.
9. Mitra GN, 1942. Rate of growth in the first year of life of *Labeorohita* and *Catlacatla* in the different districts of Orissa, ProcSci Cong, 29(3):159.
10. Prakash Shree and Gupta RA, 1986. Studies on the comparative growth rates of the three major carps of the Govindgarh Lake, IndianJ Fish, 33(1):45-53.
11. Seshappa G, 1999. Recent studies on age determination of Indian fishes using scales, otoliths and other hard parts, Indian J Fish, 46(1):1-11.
12. Ujjania NC, 2012. Comparative age and growth of Indian major carp (*Catlacatla* Ham 1822) in selected water bodies of southern Rajasthan, India, Res J Recent Sci, 1:17-22.





**Abhilash Pattnaik et al.**

**Table.1 Correlation results of *Catla catla* samples**

	<i>Catla catla</i> 1	<i>Catla catla</i> 2	<i>Catla catla</i> 3	<i>Catla catla</i> 4	<i>Catla catla</i> 5
<i>Catla catla</i> 1					
<i>Catla catla</i> 2	0.99999				
<i>Catla catla</i> 3	1	0.99999			
<i>Catla catla</i> 4	1	0.99999	1		
<i>Catla catla</i> 5	1	0.99999	0.99999	1	

**Table.2 Correlation results of *Cirrihinus reba* samples**

	<i>Cirrihinus reba</i> 1	<i>Cirrihinus reba</i> 2	<i>Cirrihinus reba</i> 3	<i>Cirrihinus reba</i> 4	<i>Cirrihinus reba</i> 5
<i>Cirrihinus reba</i> 1					
<i>Cirrihinus reba</i> 2	1				
<i>Cirrihinus reba</i> 3	1	0.99999			
<i>Cirrihinus reba</i> 4	0.99999	0.99999	0.99999		
<i>Cirrihinus reba</i> 5	1	0.99999	0.99999	0.99999	

**Table.3 Correlation results of *Ophiocephalus striatus* samples**

	<i>Ophiocephalus striatus</i> 1	<i>Ophiocephalus striatus</i> 2	<i>Ophiocephalus striatus</i> 3	<i>Ophiocephalus striatus</i> 4	<i>Ophiocephalus striatus</i> 5
<i>Ophiocephalus striatus</i> 1					
<i>Ophiocephalus striatus</i> 2	1				
<i>Ophiocephalus striatus</i> 3	1	1			
<i>Ophiocephalus striatus</i> 4	1	0.99999	1		
<i>Ophiocephalus striatus</i> 5	1	1	0.99999	0.99999	



**Fig.1 *Catla catla***

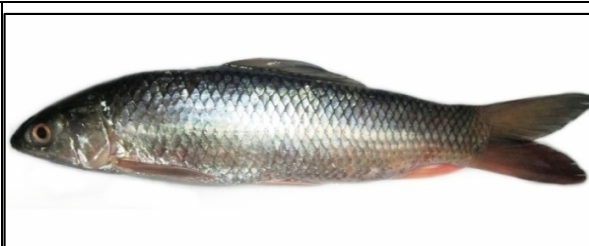

**Fig.2 *Cirrihinus reba***



**Fig.3 *Ophiocephalus striatus***





Abhilash Pattnaik et al.

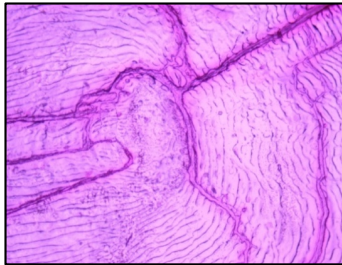

Fig.4 Scale of *C. catla* showing focus (0+ age group)

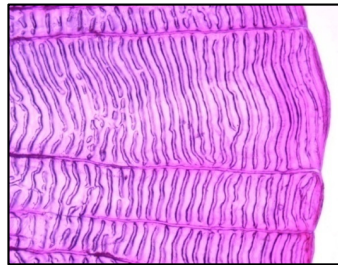

Fig.5 Scale of *C. catla* showing margin (0+ age group)

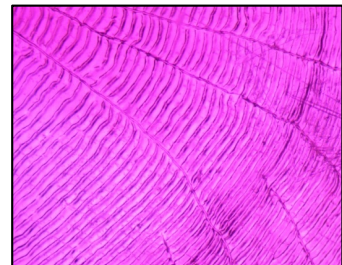

Fig.6 Scale of *C. catla* showing annual ring (1+ age group)

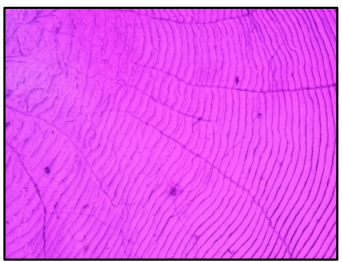

Fig.7 Scale of *C. reba* (0+ age group)

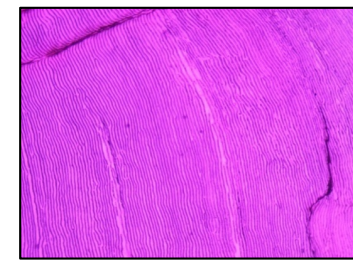

Fig.8 Scale of *O. striatus* showing annual ring (1+ age group)

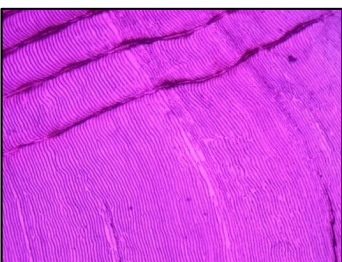

Fig.9 Scale of *O. striatus* showing annual ring (1+ age group)

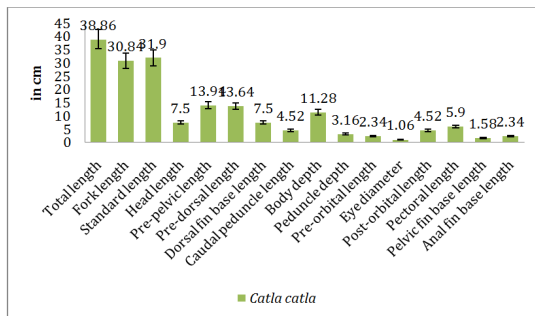

Fig.10. Morphometric graph of *Catla catla* representing the mean values

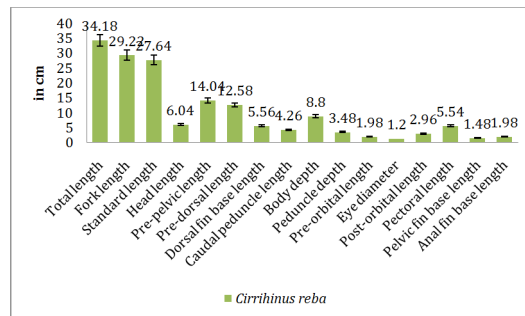

Fig. 11. Morphometric graph of *Cirrihinus reba* representing the mean values

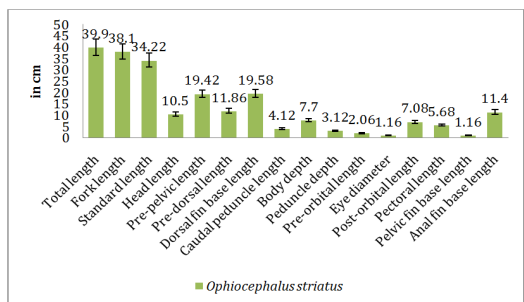

Fig.12. Morphometric graph of *Ophiocephalus striatus* representing the mean values

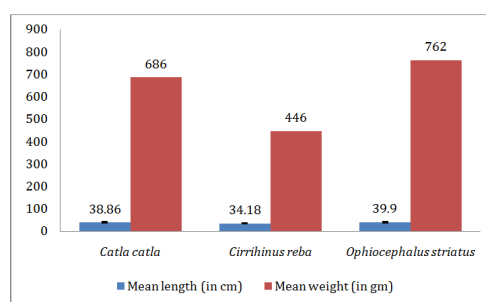

Fig.13. Comparative graph of mean values of length and weight in *Catla catla*, *Cirrihinus reba* and *Ophiocephalus striatus*





## Enumeration and Evaluation of Freshwater Microalgae for Biomass and Lipid Production

Manjunatha S.S\* and Girisha S.T

Department of Microbiology and Biotechnology, Jnanabharathi campus, Bangalore University, Bengaluru, Karnataka, India.

Received: 16 Jan 2020

Revised: 18 Feb 2020

Accepted: 21 Mar 2020

### \*Address for Correspondence

#### Manjunatha S.S

Department of Microbiology and Biotechnology,  
Jnanabharathi Campus, Bangalore University,  
Bengaluru, Karnataka, India.  
Email: manjuss168@gmail.com



This is an Open Access Journal / article distributed under the terms of the **Creative Commons Attribution License** (CC BY-NC-ND 3.0) which permits unrestricted use, distribution, and reproduction in any medium, provided the original work is properly cited. All rights reserved.

### ABSTRACT

Microalgal lipids are the oils of the future for imperishable biodiesel production. The objective of this work is to explore the potential lipid producing microalgae. In the current investigation, 52 microalgal isolates were isolated from 20 different lakes in Bengaluru city. The biomass and lipid accumulation was investigated in all the isolates, out of which five highest lipid producing isolates were chosen for further studies. Their growth was studied, followed by lipid estimation by qualitatively using fluorescence microscopy, later morphology was studied by compound microscope and scanning electron microscope. The biochemical characters were determined and finally identified by molecular method using PCR based 18S rDNA sequence analysis. The results revealed that the isolates MA-2, MA-5, MA-14, MA-38, and MA-48 were found to *Scenedesmus acutus* (MN595209), *Chlorella sorokiniana* (MN587982), *Monorapidium convolutum* (MN318951), *Actodesmus deserticola* (MN629215), *Cyclidium glaucoma* (MN319463) respectively and having the lipid contents of 37.66±0.57, 41.33±2.51, 35.66±0.57, 30.66±1.15 and 35.00±2.64 percent.

**Key words:** Microalgae, Biomass, Lipid.

### INTRODUCTION

Microalgae are the photosynthetic microorganisms (1), occur naturally in all types of systems and can indicate the condition of an ecosystem. Under natural growth conditions, microalgae absorb sunlight and carbon dioxide from environment and nutrients from the aquatic habitats, hence research on microalgae cultivation has focused on cultivating algae in clean but pricey photobioreactors or in open ponds (2). Isolation of cells on agar plate is an old and common method, it is preferred for most of the algae, purity of the culture was ensured by repeated streaking on BG 11 agar plate and conventional microscopic observation (3). The cell structure, chlorophyll and spines on the cell are morphological characters considered for identification microalgae (4). Then growth of the microalgae is evaluated in terms of biomass production. Where it's harvesting is next step (5), centrifugation is a process of





### Manjunatha and Girisha

biomass harvesting based on the size of particle and density. Where microalgae species can be induced to accumulate consequential quantities of lipids (6) and contributing to a high oil yield, which plays an important role in screening of microalgae for biodiesel production (7).

There are many reports for screening and identification of microalgal species for biodiesel production based on their high lipid contents (8), in an average lipid content ranges between 1 to 70% but under certain circumstances some species can reach 90% of dry weight (9), in this triacylglycerol and other lipids produced in microalgae can be transesterified into biodiesel (10). The yield of oil from algae is over 200 times more than the oil from plant per acre (11). Nile red stain (9-diethylamino-5H-benzo[ $\alpha$ ] phenoxaphenoxazine- 5-one) is a fluorescent dye used for in situ staining of lipids and has been most commonly used in the evaluation of lipid content in living cell (12). Photosynthetic microalgae are an exclusive natural resource for massive valuable compounds, a diversity of pigments (13). The changes in pigment levels can indicate how the organism adapts its strategy to capture light energy and convert it to biochemical energy like lipids and proteins (14). The large subunit ribosomal DNA encoding gene sequenced also confirm the identities of the microalgal species (15).

Now a days microalgae have concerned a lot of attention for the production of alternative source of energy because of the promise of reduced competition with food crop and lowered environmental impacts (16), where significant amount of lipids generated from these microalgae acceptable for production of biodiesel which is better than fossil fuels (17). Hence pertaining to above introduction in the present study, microalgae were isolated from different lakes of Bengaluru city, all the isolates were screened for their biomass as well as lipids content and characterized the highest lipid producing isolates by physical, biochemical and molecular methods.

## MATERIALS AND METHODS

### Sample collection

Water samples were collected from 20 different lakes (L-1 to L-20) in Bengaluru city, formicroalgae by the protocol of Taylor *et al.*, (18)1000 ml of algal concentrated water sample was collected in sterile, non-reactive plastic bottles from Yelahanka lake (L-1), Hebbal lake (L-2), Ullal lake (L-3), Kommaghatta lake (L-4), Agara lake (L-5), Mallathalli lake (L-6), Hesaraghatta lake (L-7), Madiwala lake (L-8), Allalsandra lake (L-9), Varthuru lake (L-10), Sulikere lake (L-11), Sathanuru lake (L-12), Kattigenahalli lake (L-13), Herohalli lake (L-14), Dore lake (L-15), Kogilu lake (L-16), Bagaluru lake (L-17), Chikkabanavara lake (L-18), Nagavara lake (L-19) and Ulsoor lake (L-20).

### Isolation of algal isolates

10 ml of the water sample was inoculated into the 250 ml flasks containing BG11 media and incubated at room temperature (28 $\pm$ 2°C) under 16:8 h light: dark condition fluorescent white light for 4 weeks for preliminary growth. Each 1000ml of BG11 media contained 1.5 g Sodium Nitrate, 0.02 g Sodium Carbonate, 0.4 g di-Potassium Hydrogen Phosphate, 0.75 g magnesium Sulphate Heptahydrate, 0.36 g Calcium Chloride di-hydrate, 6 mg Citric Acid, 6 mg Ammonium Ferric Citrate, 2.86 mg Boric Acid, 1.81 mg Manganese Chloride, 0.22 mg Zinc Sulphate Heptahydrate, 0.39 mg Sodium Molybdate, 0.08 mg Copper Sulphate, 0.05 mg Cobalt Nitrate, 0.01 mg EDTA (19). Pure cultures were isolated by centrifugation and washing, washed microalgae allowed to streak through loop in plates in axenic condition and to keep for at least seven days to grow. Repeated streak-plating was carried out to pick up single colony from earlier streaked plates and to make it pure. From last streaked plates, single colonies was picked up by loop and allowed to grow in flasks, before inoculating in the flasks, the single cell growth and purity of single species will be confirmed by observing under (40x and 100x) microscope (20).



**Manjunatha and Girisha****Estimation of biomass and lipids**

All the cultures were harvested from BG 11 media (incubated in 250 ml flask at room temperature under 16:8h light: dark condition for 4 weeks) in stationary phase by centrifugation at 8000 rpm, the pellet was washed with distilled water to remove residual salts, where the biomass content was estimated using gravimetric method(21). Where as their lipid content was extracted by protocol of Bligh & Dyer (22) and estimated gravimetrically.

**Cultivation of high lipid yielding microalgae and their growth curve**

Among the isolates 5 maximum lipid yielding microalgae are selected for further work. The pure culture inoculated BG 11 flasks were incubated at 28±2 °C for 20 days in an artificial light chamber under illumination with a white fluorescent light intensity of 2000 lx at 16:8 h light: dark conditions and the growth curves were plotted by measuring the optical density of algal samples cultivated in BG-11 media at 680 nm using a colorimeter (ELICO CL 63) for every three days according to Dziosa & Makowska (23).

**Staining of lipid**

The stock solutions of Nile red (100 µg/ml) was prepared in acetone, protected from light and staining was carried out on fixed (1.5% glutaraldehyde, 5 min) cells. Isolated cells (1-2 x 10<sup>6</sup>/ml) were suspended in PBS, dye was added directly to the preparation to effect an 1:100 dilution and the preparation was incubated for 10 min in dark and observed under fluorescence microscopy with a Zeiss Universal Photomicroscope (Carl Zeiss, Inc., Thornwood, NY) equipped for epi-illumination using an HBO 200 high pressure mercury light source, in the present study, the stained cells were observed in yellow-gold fluorescence using a 450-500 nm band pass exciter filter and with 10x and 40x plan neofluar objective lenses (24).

**Characterization of microalgae****Morphological studies**

The single species cultivated in flask were ensured by observing under binocular compound microscope (CX41RF, Olympus Corporation, Tokyo, Japan), compared with algae identification manuals and for further confirmation SEM studies are carried out, here dried powder of algae were mounted onto a specimen stub using double-sided adhesive carbon tape and sputter-coated with gold before examination under the microscope (25) and image analysis of the samples was performed using SEM (Zeiss Ultra plus FEG) at an acceleration voltage of 10 kV and the magnification of 2 kx to 5 kx.

**Biochemical studies**

In biochemical study, total protein content, total chlorophyll content and carotenoids content are studied, where total protein content was estimated by Lowry's method by following (26), total chlorophyll content by procedure of Arnon(27) and total carotenoids content by Kirk & Allen(28).

**Molecular studies**

Similarly, 5 high lipid yielding microalgae were further subjected for molecular identification using PCR based 18S rDNA sequence analysis (29). Briefly, cultured cells (500 mg) were harvested from 10 days incubated flasks by centrifugation at 8,000 rpm for 10 min (REMI) and the obtained cell pellets were washed twice using sterile water. Total DNA was extracted using a genomic DNA extraction kit procured from Aristogene Bioscience Pvt Ltd





**Manjunatha and Girisha**

(Bangalore, India). The DNA extracts were analysed by electrophoresis using 1.5% agarose gel to confirm the presence of extracted DNA and used for amplification with PCR (Q cycler, CM 6050, Quanta Biotech, Surrey, UK). The primer 50TGATCCTTCYGCAGGTTAC30 served as forward primer and the primer 50ACCTGGTTGATCCTGCCAG30 served as reverse primer. The amplification was carried out in 25 ml of a mixture containing 50 ng of genomic DNA, 2.5 ml of 10 $\times$  buffer, 1 ml of 25 mM MgCl<sub>2</sub>, 3 ml of the 2 mM dNTPs, 0.5 ml of 1.5 U DNA Taq polymerase, 1.5 ml of 10 pM each primer and 14.5 ml of sterile distilled water. The cycling conditions comprised initialization at 94°C for 5 min, denaturation at 94 °C for 30 s, annealing at 55 °C for 30 s and elongation at 72 °C for 1 min. PCR products were analysed by electrophoresis using 1.5% agarose gel for confirmation of amplification and submitted to base sequence analysis at Eurofins Genomics Pvt Ltd (Bangalore, India). The 18S rDNA sequences of the isolates were searched against GenBank using the BLAST search tool and the phylogenetic tree was constructed based on similarities between related taxa. Finally submitted to NCBI and obtained accession numbers

**Statistical analysis**

All of the experiments were carried in triplicate and data presented are mean values of three replicates. Microsoft Excel was used for the evaluation of mean values and standard deviations of the different experiments.

**RESULT AND DISCUSSION****Biomass and lipid content of isolates**

The biomass (gL<sup>-1</sup>) and lipid content (%) of 52 isolates MA (Micro Algae) -1 to MA-52 from 20 different lakes L-1 to L-20 of Bengaluru city are cultivated in BG11 medium for 20 days and illustrated in table 1. Most of the lakes contain more than 3 species, the diversity indicates the polluted water level, because the algae is well known for growth in polluted water. The Biomass and percentage of lipids vary among the species and among the isolated lakes. According to (30) the microalgae with high biomass productivity and lipid content are important for biodiesel production in concern with this, in present studies the biomass and lipid percentage were determined. The biomass ranges from 0.60 $\pm$ 0.08gL<sup>-1</sup> (MA-25) to 2.97 $\pm$ 0.02gL<sup>-1</sup> (MA- 28) and the lipid content of the biomass varies from 7.66 $\pm$ 2.51% (MA-34) to 41.33 $\pm$ 2.51% (MA-5). Regarding to this in previous studies, Hu *et al.*, (31) reported that the total lipid content under optimal growth conditions varied between 5 to 20%, the lipid content in the present isolates was at the higher end of this. According to (32), microalgae with a total lipid content >20% can be considered as potential biodiesel feedstocks, on this basis, the resultant lipid content in the study indicates that there are 31 potential isolates obtained out of 52 for sources of biodiesel. Out of which 5 highest lipid producing microalgae are selected for further work.

**Growth curve of high lipid yielding isolates**

Dziosa & Makowska (23) described the growth curve of *Chlorella* sp. by adsorption peak at about 680 nm, in the present research the results of five algal species depicted that, the lag phases were observed up to 3<sup>rd</sup> day, where the isolates were adapted well, the exponential growth phase starts from 3<sup>rd</sup> day onwards and continues up to 18<sup>th</sup> day in all the five cultures except MA-48, where it stops at 15<sup>th</sup> day, the stationary phase continues from 18<sup>th</sup> to 20<sup>th</sup> day and decline phase starts immediately after the end of stationary phase as shown in figure 1, where similar studies are also made by (33) in *Pseudokirchneriella subcapitata* obtained alike growth curve.

**Nile red staining**

In preliminary studies to screen the lipid inclusion in the isolated strains Nile red staining was performed which shows in figure 2 Nile red is responsible for the metachromatic coloring of tissue lipids by staining procedures (34).



**Manjunatha and Girisha**

The results depicted that the appearance of stained cells viewed for yellow-gold fluorescence intensities of cellular lipid indicates high lipid content. The lipid granules were throughout the cell, where minimum fluorescence intensities were found in MA-38, MA-2 and maximum in MA-5, MA-14, MA-48. Sharma *et al.*, (6) screened *Chlorella* sp. for lipid content by Nile red staining method and confirmed the presence of intracellular lipid droplets as detected by fluorescent microscope with excitation wavelength at 420 nm and emission at 580 nm and similar finding have also been reported by (35-37)

**Morphological studies**

Based on lipid content, the selected isolates were morphologically identified by microscopic study and compared with the book "Algae Identification lab guide" by Agriculture and Agri-Food Canada (2011) and "Easy identification of the most common freshwater algae" by (38), the images were shown in figure 3. All the selected microalgae samples are photosynthetic, the cells of MA-2 is identified as *Scenedesmus* sp. on the basis of its shape, the cells are cylindrical, with round or tapered end, which is confirmed by the recorded observation of (39). Patil & Meti (40) observed the characters of round, small and normally individually dissociated cells in his studies, where in our studies the characters of MA-5 are similar to *Chlorella* sp. MA-14 cells are identified as *Monoraphidium* sp. on the basis of crescent shape cells which is confirmed by the previous report of (41-42) described the characters of cylindrical cells with pointed ends in his studies, in the present study MA-38 cells are showed the similar characters and identified as *Actodesmus* sp. and the fifth one MA-48 is identified as *Cyclidium* sp. on the basis of its ovoid shape as reported by Guggiari & Peck (43), further the identification was confirmed with molecular analysis.

The SEM provided very high quality, exquisite, substantial, inclusive and well-contrasted view of microalgae (44). The MA-2 isolate shows the cylindrical shape, tapered end, 8.65-10.25 long and 4.53-5.34  $\mu\text{m}$  wide. MA-5 isolate is circular shape with 2.02-2.74  $\mu\text{m}$  size, MA-14 isolate is crescent shape and 4.95-7.12 x 1.71-2.49  $\mu\text{m}$ , MA-38 shows the cylindrical shape, pointed end with 9.26-12.11 x 3.32-4.56  $\mu\text{m}$ , MA-48 is ovoid in shape with 2.45-4.12 x 2.02-3.50  $\mu\text{m}$  size as shown in figure 4. Previously many researchers have used SEM to study the morphological characters, Okolodkov & Huerta-Quintanilla (45) studied the morphology in marine Dinoflagellates, (46) studied in *Haematococcus* sp. and (44) studied in mixed microalgae species.

**Biochemical studies**

The biochemical characters like chlorophyll, carotenoids and protein are studied and the results are as follows. Chlorophyll 'a' is the most abundant pigment in all plants and green microalgae and followed by chlorophyll 'b' (47). The chlorophyll contents in all 5 isolates shown in figure 5 which depicted that lowest chlorophyll 'a' content was observed in MA-5 (0.002  $\pm$  0.001 mg/g) and highest in MA-14 (0.268  $\pm$  0.03 mg/g), similarly chlorophyll 'b' content was lowest in MA-5 (0.02  $\pm$  0.01 mg/g) and highest in MA-14 (0.43  $\pm$  0.02 mg/g) and total chlorophyll content was minimum in MA-5 (0.36  $\pm$  0.01 mg/g) compare to MA-14 (1.02  $\pm$  0.01 mg/g) which was the highest. Muthuraman & Ranganathan (48) reported that highest total chlorophyll in green algae *Chlorella* sp. and lowest in red algae. Similarly, (49) reported 0.022 mg of highest total chlorophyll content in their studies *Scenedesmus dimorphus* compare to this the isolated strains shows more chlorophyll content than others.

Carotenoids synthesis is dependent on cellular physiology and metabolism (50), its production caused by excessive formation of free radicals, and also essential for continuation of growth (51), in this regard in the present research lowest carotenoids was recorded in MA-48 (0.10  $\pm$  0.006  $\mu\text{g/g}$ ) and the highest in MA-14 (0.39  $\pm$  0.009  $\mu\text{g/g}$ ) (Figure 6). Bujard *et al.*, (52) find out that the carotenoids contents in *Spirulina* was just 0.01 to 0.2 % of dry weight, which is supported by (53) who found 6.04  $\pm$  0.03  $\mu\text{g/mL}$  carotenoids in *Micractinium* sp. The protein content in the microalgal cells is directly related to its growth (54), protein content varies among all the five algal isolates, where MA-2 showed lowest protein content of 24.83  $\pm$  1.86% compare to MA-38 which shows 42.06  $\pm$  3.77% (Figure 7). Jesus *et al.*, (55)



**Manjunatha and Girisha**

reported highest protein of 39.7% in *Coccomyxa* sp. and the lowest content in *Scenedesmus* sp. (12.9%). Similarly, (56) studied the total protein contents of *Chlorella vulgaris* was 46 % which supports with our results.

**Molecular studies**

After the study of morphological, biochemical characters the significant lipid producing 5 isolates were selected for identification at their molecular level by using PCR based 18S rDNA sequencing. In this study the obtained phylogenetic sequence of MA-2 had been synonymized with *Scenedesmus acutus* (MN595209) within the Gene bank (Figure 8), MA-5 showed most similarity to *Chlorella sorokiniana* (MN587982) strains within the Gene bank (Figure 9), MA-14 showed similarity to *Monorapidium convolutum* (MN318951) strains within the Gene bank (Figure 10), MA-38 similarity to *Actodesmus deserticola* (MN629215) strains within the Gene bank (Figure 11) and MA-48 similarity to *Cyclidium glaucoma* (MN319463) strains within the Gene bank (Figure 12).

**CONCLUSION**

These results indicate that the lakes in Bengaluru city are rich in diversity of microalgae, which can produce higher biomass and lipid content. The isolates are varied in their lipid percentage between 8-41%. Out of 52 isolates 5 highest lipid producing microalgae (36-41%) were studied. Further studies are still needed to explore the locally available microalgae with different nutrient media and their compositions to study optimized biomass and lipid production conditions. Strains represent promising oleaginous algae worthy of further exploration for biodiesel production.

**ACKNOWLEDGEMENTS**

The author is thank full to Department of Backward classes' welfare, Government of Karnataka for funding this work and Bangalore University for SAP laboratory facilities.

**REFERENCES**

1. Kumar MS & Buddolla V, Future prospects of biodiesel production by microalgae: A short review, In *Recent Developments in Applied Microbiology and Biochemistry*, Academic Press 2019; 161-166.
2. Mata TM, Martins AA & Caetano NS, Microalgae for biodiesel production and other applications: a review, *Renew Sust Energy Rev* 2010; 14(1): 217-232.
3. Tale M, Ghosh S, Kapadnis B & Kale S, Isolation and characterization of microalgae for biodiesel production from Nisargruna biogas plant effluent, *Bioresource technology* 2014; 169: 328-335.
4. Barsanti L & Gualtieri P, *Algae: anatomy, biochemistry, and biotechnology*. CRC press 2014.
5. Okoro V, Azimov U, Munoz J, Hernandez HH & Phan AN, Microalgae cultivation and harvesting: Growth performance and use of flocculants-A review, *Renewable and Sustainable Energy Reviews* 2019; 115:p.109364.
6. Sheehan J, Danaher T, Benemann J, Roessler P, A look back at the U.S. Department of Energy's aquatic species program: biodiesel from algae. *National Renewable Energy Laboratory, USA, 1998; 328:1-294*
7. Sharma J, Kumar SS, Bishnoi NR & Pugazhendhi A, Screening and enrichment of high lipid producing microalgal consortia, *J of Photochemistry and Photobiology B: Biology* 2019; 192: 8-12.
8. Griffiths MJ, van Hille RP & Harrison ST, Lipid productivity, settling potential and fatty acid profile of 11 microalgal species grown under nitrogen replete and limited conditions, *J of Applied Phycology* 2012; 24(5):989-1001.
9. Li Y, Wang B, Wu N & Lan CQ, Effects of nitrogen sources on cell growth and lipid production of *Neochloris oleoabundans*, *Applied Microbiology and Biotechnology* 2008; 81(4): 629-636.
10. Scott SA, Davey MP, Dennis JS, Horst I, Howe CJ, Lea-Smith DJ & Smith AG, Biodiesel from algae: challenges and prospects, *Current opinion in biotechnology* 2010; 21(3): 277-286.



**Manjunatha and Girisha**

11. Sheehan J, Dunahay T, Benemann J & Roessler P, A Look Back at the US Department of Energy's Aquatic Species. *Close-Out Report National Renewable Energy Laboratory, US Department of Energy's Office of Fuels Development, Golden, Colorado, USA*1998.
12. Mrunalini BR & Girisha ST, Screening and Characterization of Lipid inclusions in Bacteria by Fluorescence Microscopy and Mass Spectrometry as a Source for Biofuel Production, *Indian Jof Science and Technology* 2017; 10:21.
13. Del Campo JA, Garcia-Gonzalez M & Guerrero MG, Outdoor cultivation of microalgae for carotenoid production: current state and perspectives. *Applied microbiology and biotechnology* 2007; 74(6): 1163-1174.
14. Chen Y & Vaidyanathan S, Simultaneous assay of pigments, carbohydrates, proteins and lipids in microalgae, *Analytical chimica acta* 2013; 776: 31-40.
15. Abou-Shanab RA, Matter IA, Kim SN, Oh YK, Choi J & Jeon BH, Characterization and identification of lipid-producing microalgae species isolated from a freshwater lake, *Biomass and Bioenergy* 2011; 35(7): 3079-3085.
16. Morales M, Collet P, Lardon L, Helias A, Steyer JP & Bernard O, Life-cycle assessment of microalgal-based biofuel, *Biofuels from Algae* 2019; 507-550.
17. Ahmad AL, Yasin NM, Derek CJC & Lim JK, Microalgae as a sustainable energy source for biodiesel production: a review, *Renewable and Sustainable Energy Reviews* 2011; 15(1): 584-593.
18. Taylor JC, Prygiel J, Vosloo A, Rey PA & Rensburg L, Can diatom-based pollution indices be used for biomonitoring in South Africa? A case study of the Crocodile West and Marico water management area. *Hydrobiologia* 2007; 592(1): 455-64.
19. *ATCC Catalogue of Bacteria & Bacteriophages 18th edition 1992.*
20. Phang SM & Chu WL, University of Malaya, Algae culture Collection, Catalogue of Strains. Institute of Post Graduate Studies and Research, University of Malaya, Kuala Lumpur, Malaysia 1999; p.77.
21. Sathya S & Srisudha S, Isolation and identification of freshwater microalgal strains potential for biofuel production, *Int J Recent Sci Res* 2013; 4: 1432-1437.
22. Bligh EG & Dyer WJ, A rapid method of total lipid extraction and purification, *Canadian journal of biochemistry and physiology* 1959; 37: 911-917.
23. Dzios K & Makowska M, Monitoring of Chlorella sp. growth based on the optical density measurement, *Problemy Eksploatacji* 2016.
24. Greenspan P, Fowler SD, Spectrofluorometric studies of the lipid probe, Nile red, *Jof lipid research* 1985; 26(7): 781-789.
25. Ansari FA, Gupta SK, Nasr M, Rawat I & Bux F, Evaluation of various cell drying and disruption techniques for sustainable metabolite extractions from microalgae grown in wastewater: A multivariate approach, *J of cleaner production* 2018; 182: 634-643.
26. Lowry OH, Rosebrough NJ, Farr AL & Randall RJ, Protein measurement with the Folin phenol reagent, *Journal of biological chemistry* 1951; 193: 265-275.
27. Arnon DI, Copper enzymes in isolated chloroplasts. Polyphenoloxidase in Beta vulgaris, *Plant physiology* 1949; 24(1): 1.
28. Kirk JTO & Allen RL, Dependence of chloroplast pigment synthesis on protein synthesis: effect of actidione, *Biochemical and Biophysical Research Communications* 1965; 21(6): 523-530.
29. Eland LE, Davenport R & Mota CR, Evaluation of DNA extraction methods for freshwater eukaryotic microalgae, *Water research* 2012; 46(16): 5355-5364.
30. Zhao X, Zhou Y, Huang S, Qiu D, Schideman L, Chai X & Zhao Y, Characterization of microalgae-bacteria consortium cultured in landfill leachate for carbon fixation and lipid production, *Bioresource technology* 2014; 156: 322-328.
31. Hu Q, Sommerfeld M, Jarvis E, Ghirardi M, Posewitz M, Seibert M & Darzins, Microalgal triacylglycerols as feedstocks for biofuel production: perspectives and advances, *The plant journal* 2008; 54(4): 621-639.
32. Gong Y & Jiang M, Biodiesel production with microalgae as feedstock: from strains to biodiesel, *Biotechnology letters* 2011; 33(7): 1269-1284.





### Manjunatha and Girisha

33. Rodrigues LHR, Raya-Rodriguez MT & Fontoura NF, Algal density assessed by spectrophotometry: a calibration curve for the unicellular algae *Pseudokirchneriella subcapitata*, *J of Environmental Chemistry and Ecotoxicology* 2011; 3(8): 225-228.
34. Greenspan P, Mayer EP & Fowler SD, Nile red: a selective fluorescent stain for intracellular lipid droplets, *The Jof cell biology* 1985; 100(3):965-973.
35. Abdo SM, Ahmed E, El-Enin SA, El Din RS & Ali GE, Qualitative and quantitative determination of lipid content in microalgae for biofuel production, *J. Algal Biomass Utiln* 2014; 5(3):23-28.
36. Kirrolia A, Bishnoi NR & Singh R, Microalgae as a boon for sustainable energy production and its future research & development aspect, *Renewable and Sustainable Energy Reviews* 2013; 20:642-656.
37. Kiran B, Pathak K, Kumar R, Deshmukh D & Rani N, Influence of varying nitrogen levels on lipid accumulation in *Chlorella* sp., *International j of environmental science and technology* 2016; 13(7):1823-1832.
38. Van Vuuren SJ, Taylor J, Gerber A & Van Ginkel C, Easy identification of the most common freshwater algae: a guide for the identification of microscopic algae in South African freshwaters, *Resource Quality Services* 2006.
39. Fadjria, N., & Zainul, R. Isolation and molecular identification of freshwater microalgae in maninjau lake west Sumatera 2018.
40. Patil PC & Meti BS, Isolation of microalgae for biomass and lipid enhancement through placket-Burman Design, *Int J Currmicrobiol AppSci* 2018; 7(3):2508-2518.
41. Huang L, Xu J, Li T, Wang L, Deng T & Yu X, Effects of additional Mg<sup>2+</sup> on the growth, lipid production, and fatty acid composition of *Monoraphidium* sp. FXY-10 under different culture conditions, *Annals of microbiology* 2014; 64(3): 1247-1256.
42. Li X, Hu HY & Yang J, Lipid accumulation and nutrients removal properties in secondary effluent of a newly-isolated freshwater microalga *Scenedesmus* sp. LX1, *New Biotechnol* 2010; 27(1):59-63.
43. Guggiari M, & Peck R, The bacterivorous ciliate *Cyclidium glaucoma* isolated from a sewage treatment plant: molecular and cytological descriptions for barcoding, *European j of protistology* 2008; 44(3): 168-180.
44. Hossain N, Zaini J, Mahlia TMI & Azad AK, Elemental, morphological and thermal analysis of mixed microalgae species from drain water, *Renewable energy* 2019; 13:617-624.
45. Okolodkov YB & Huerta-Quintanilla DA, A Low Voltage Scanning Electron Microscopy Study of the Theca of Marine Dinoflagellates, *J of Advanced Microscopy Research* 2012; 7(3): 170-175.
46. Kim JH, Affan MA, Jang J, Kang MH, Ko AR, Jeon SM & Kang DH, Morphological, molecular, and biochemical characterization of astaxanthin-producing green microalga *Haematococcus* sp. KORDI03 (*Haematococcaceae*, *Chlorophyta*) isolated from Korea, *J Microbiol. Biotechnol* 2015; 25(2):238-246.
47. da Silva Ferreira V & Sant'Anna C, Impact of culture conditions on the chlorophyll content of microalgae for biotechnological applications, *World J of Microbio and Biotechnol* 2017; 33(1): 20.
48. Muthuraman B & Ranganathan R, Biochemical studies on some green algae of Kanyakumari coast, *Seaweed Research and Utilization* 2004; 26(1&2): 69-71.
49. Bajwa K, Bishnoi NR & Kirrollia A, A New Lipid Rich Microalgal SP *Scenedesmus Dimorphus* Isolated: Nile Red Staining and Effect of Carbon, Nitrogen Sources on its Physio-Biochemical Components, *European J of Sustainable Development Research* 2018; 2(4): 43.
50. Stephenson PG, Moore CM, Terry MJ, Zubkov MV & Bibby TS, Improving photosynthesis for algal biofuels: toward a green revolution, *Trends in biotechnology* 2011; 29(12): 615-623.
51. Dipak SP & Lele SS, Carotenoid production from microalga *Dunaliella salina*, *Indian J of Biotech* 2005; 4:476-483.
52. Bujard E, Baco U, Mauron J, Mottu F, Nabholz A, Wuhrmann JJ & Clément G, Composition and nutritive value of blue green algae (*Spirulina*) and their possible use in food formulations, In *3rd International Congress of Food Science and Technology* 1970.
53. Dharma A, Sekatresna W, Zein R, Chaidir Z & Nasir N, Chlorophyll and Total Carotenoid Contents in Microalgae Isolated from Local Industry Effluent in West Sumatera, Indonesia, *Der PharmaChemica* 2017; 9(18): 9-11.
54. Guldhe A, Ansari FA, Singh P & Bux F, Heterotrophic cultivation of microalgae using aquaculture wastewater: a biorefinery concept for biomass production and nutrient remediation, *Ecological engineering* 2017; 99: 47-53.





### Manjunatha and Girisha

55. Jesus HSD, Cassini STA, Pereira MV, Dassoler AF & Gonçalves RF, Autochthonous microalgae cultivation with anaerobic effluent: isolation of strains, survivorship, and characterization of the produced biomass, *Revista Ambiente & Água* 2019; 14(4).
56. Seyfabadi J, Ramezanzpour Z & Khoeyi ZA, Protein, fatty acid, and pigment content of *Chlorella vulgaris* under different light regimes, *J of Applied Phycology* 2011; 23(4): 721-726.

**Table 1: Microalgal biomass and lipid percentage**

Sl. No.	Lakes	Isolate name	Biomass gL <sup>-1</sup>	Lipid %
L-1	Yelahanka lake	MA-1	2.17±0.14	27.33±0.57
		MA-2	2.82±0.12	37.66±0.57
		MA-3	2.67±0.13	18.33±4.72
		MA-4	1.03±0.06	21.00±3.00
L-2	Hebbal lake	MA-5	2.33±0.20	41.33±2.51
		MA-6	1.96±0.09	21.66±2.30
		MA-7	2.11±0.17	30.66±3.05
		MA-8	2.22±0.15	17.66±4.04
L-3	Ullal lake	MA-9	1.96±0.05	21.33±2.39
		MA-10	1.09±0.10	22.66±3.21
		MA-11	2.63±0.16	17.66±3.21
L-4	Kommaghatta lake	MA-12	2.05±0.09	17.00±0.00
		M-A13	1.65±0.14	27.66±0.57
L-5	Agara lake	MA-14	1.83±0.10	35.66±0.57
		MA-15	1.70±0.12	20.33±1.52
		MA-16	1.51±0.11	20.00±1.73
L-6	Mallathalli lake	MA-17	2.10±0.25	16.66±1.52
		MA-18	1.11±0.01	12.00±2.64
L-7	Hesaraghatta lake	MA-19	0.98±0.14	20.66±2.08
		MA-20	1.28±0.26	27.66±3.51
L-8	Madiwala lake	MA-21	1.58±0.00	19.33±1.15
		MA-22	1.10±0.00	20.66±3.05
		MA-23	1.43±0.18	26.66±2.30
L-9	Allalsandra lake	MA-24	1.11±0.09	17.33±2.08
		MA-25	0.60±0.08	10.33±2.08
L-10	Varthuru lake	MA-26	1.28±0.00	15.00±4.58
		MA-27	1.72±0.00	19.00±1.00
		MA-28	2.97±0.02	35.33±2.08
L-11	Sulikere lake	MA-29	1.23±0.00	25.33±0.57
L-12	Sathanuru lake	MA-30	2.01±0.12	23.00±0.00
L-13	Kattigenahalli lake	MA-31	2.58±0.01	25.00±2.64
		MA-32	1.54±0.01	10.33±1.15
L-14	Herohalli lake	MA-33	1.75±0.00	18.00±4.00
		MA-34	1.52±0.02	07.66±2.51
		MA-35	0.69±0.02	22.00±1.00
L-15	Dore lake	MA-36	1.68±0.01	26.00±0.00
		MA-37	0.82±0.04	13.33±2.51
		MA-38	1.08±0.03	30.66±1.15





**Manjunatha and Girisha**

<b>L-16</b>	Kogilu lake	MA-39	1.69±0.06	17.66±0.57
		MA-40	1.97±0.40	10.66±2.08
<b>L-17</b>	Bagaluru lake	MA-41	1.46±0.21	22.33±2.88
		MA-42	0.89±0.20	12.00±1.73
<b>L-18</b>	Chikkabanavara lake	MA-43	0.68±0.07	16.33±2.88
		MA-44	2.16±0.04	20.33±2.51
		MA-45	0.98±0.26	25.33±3.05
<b>L-19</b>	Nagavara lake	MA-46	1.66±0.12	22.66±2.08
		MA-47	0.99±0.10	20.33±1.52
		MA-48	2.09±0.01	35.00±2.64
		MA-49	1.22±0.00	26.00±1.00
<b>L-20</b>	Ulsoor lake	MA-50	1.60±0.04	25.33±1.52
		MA-51	0.93±0.01	19.66±0.57
		MA-52	1.21±0.01	15.00±0.00

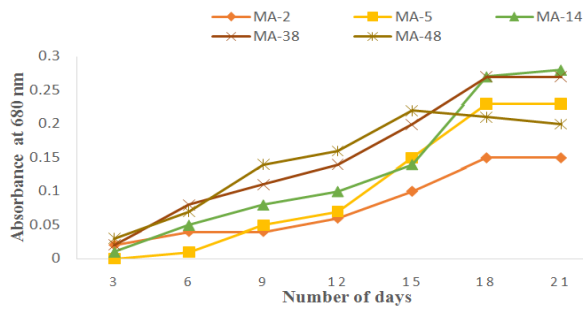

Figure 1: Growth curve of highest lipid producing microalgae.

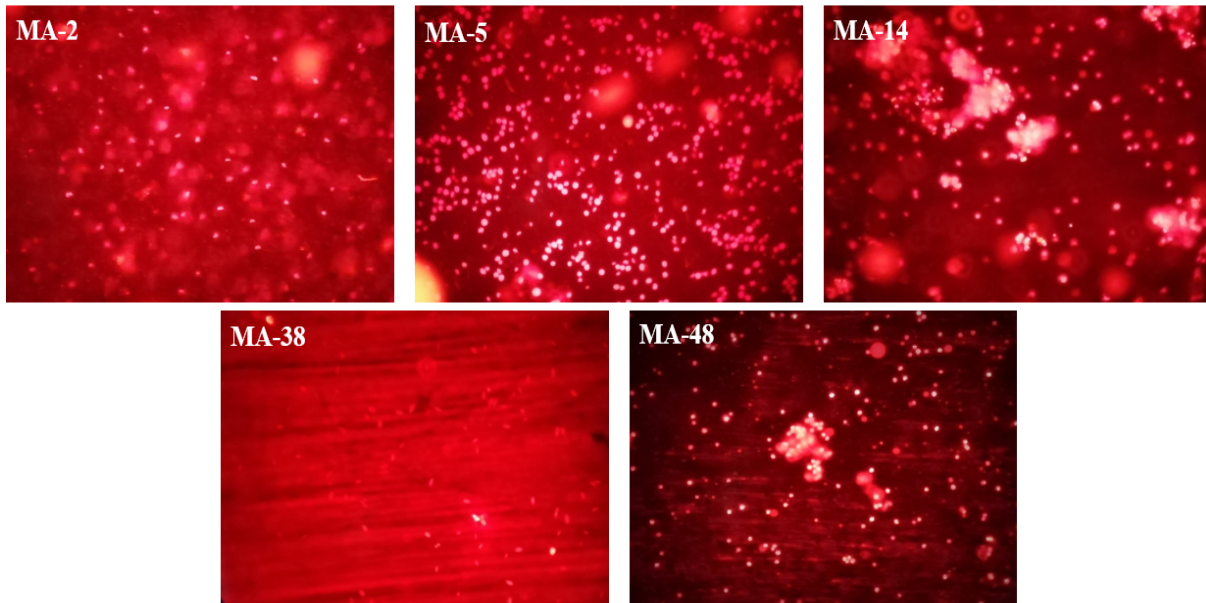

Figure 2: Nile red stained cells of microalgae under 40X





Manjunatha and Girisha

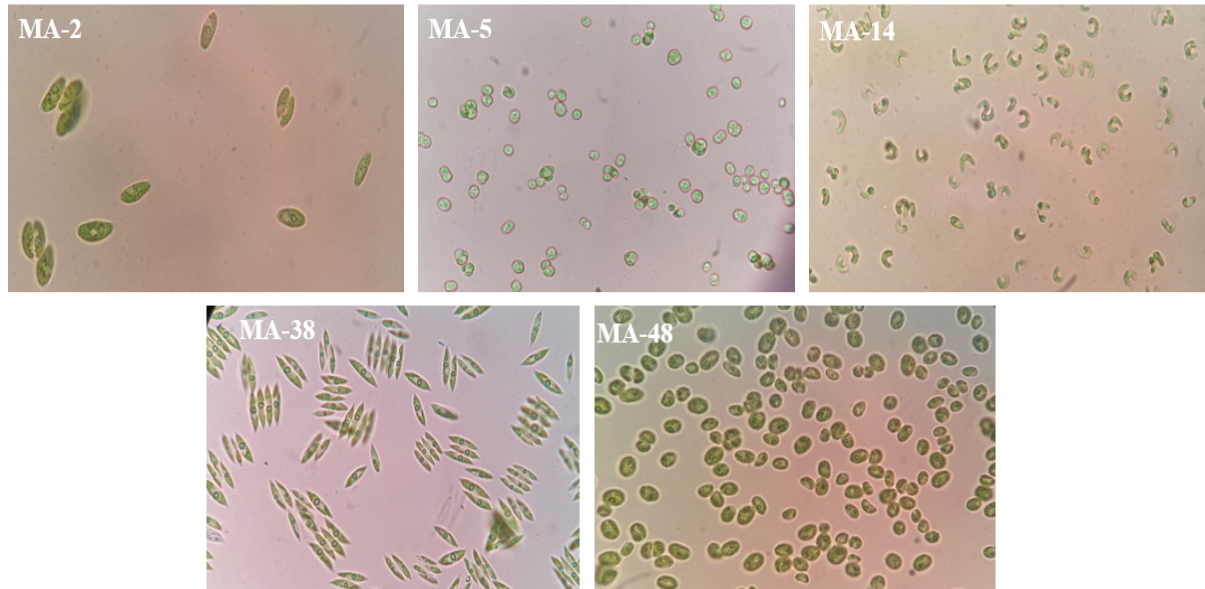

Figure 3: Microscopic view of selected isolates (100X)

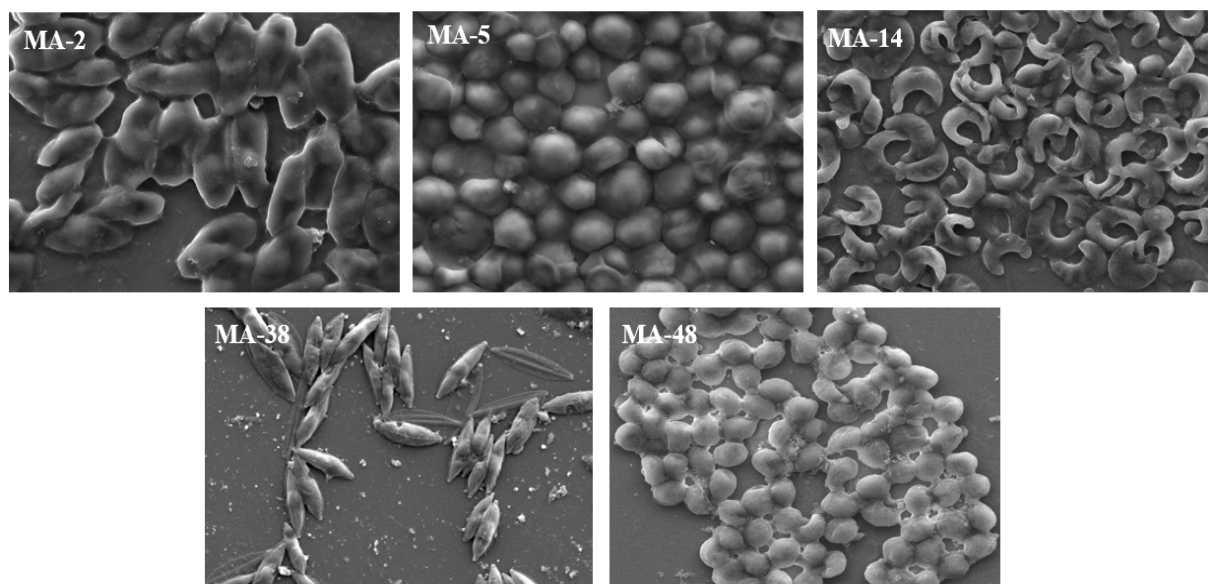

Figure 4: SEM images of microalgae isolates at an acceleration voltage of 10 kV and 5 kx magnification







**Manjunatha and Girisha**

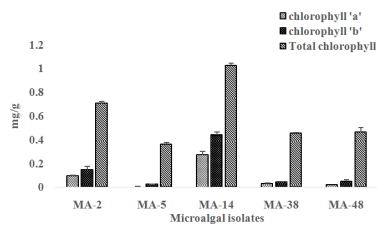

**Figure 5: Chlorophyll 'a', Chlorophyll 'b' & total chlorophyll contents of microalgae**

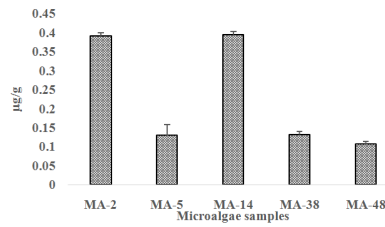

**Figure 6: Carotenoid contents of microalgae.**

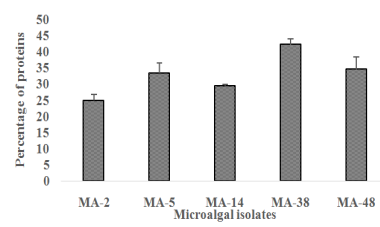

**Figure 7: Protein content in microalgae.**

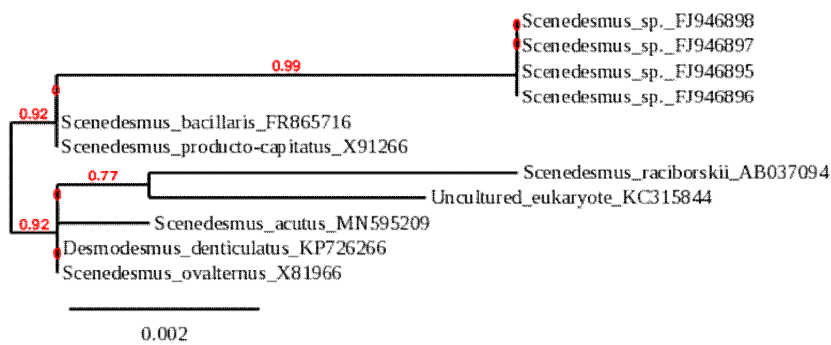

**Figure 8: Phylogenetic tree depicts results for MA-2**

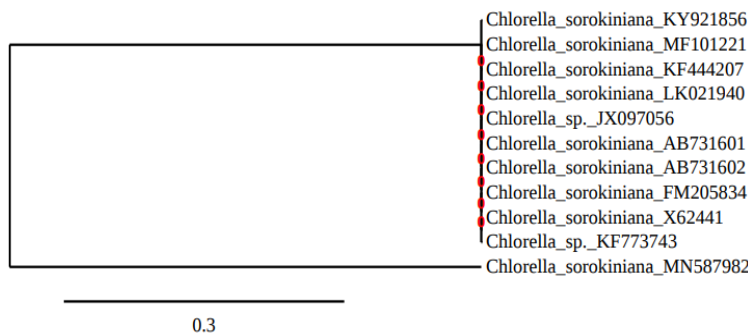

**Figure 9: phylogenetic tree depicts results for MA-5**

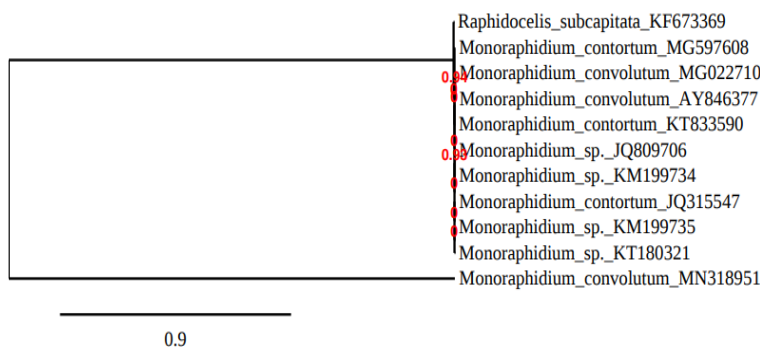
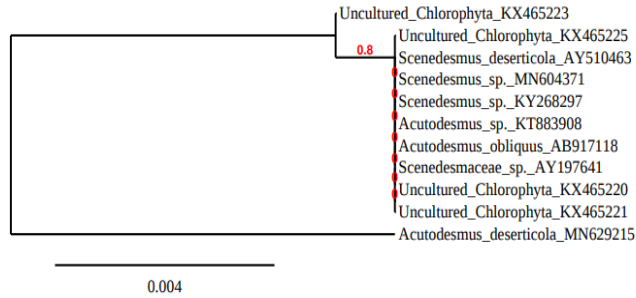

**Figure 10: phylogenetic tree depicts results for MA-14**





**Manjunatha and Girisha**



**Figure 11: phylogenetic tree depicts results for MA-38**

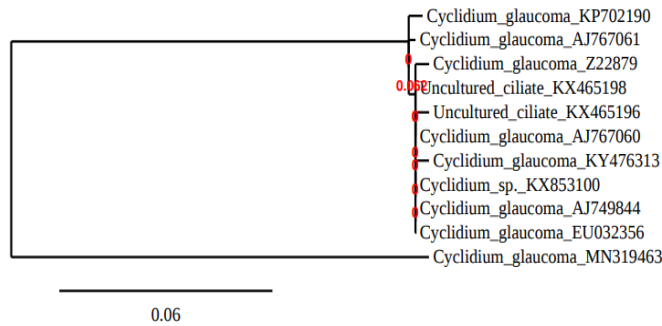

**Figure 12: phylogenetic tree depicts results for MA-48**





## Application of *Azotobacter vinelandii* SINAz1 Increases Growth and Productivity in Rice Plants in Salinity Stress

Ranjan Kumar Sahoo<sup>1\*</sup> and Madhusmita Pradhan<sup>2</sup>

<sup>1</sup>Department of Biotechnology, Centurion University of Technology and Management, Odisha, India

<sup>2</sup> PG Department of Botany, Utkal University, Bhubaneswar, Odisha, India.

Received: 13 Jan 2020

Revised: 16 Feb 2020

Accepted: 20 Mar 2020

### \*Address for Correspondence

**Ranjan Kumar Sahoo**

Department of Biotechnology,  
Centurion University of Technology and Management,  
Odisha, India.

Email: ranjan.sahoo@cutm.ac.in



This is an Open Access Journal / article distributed under the terms of the **Creative Commons Attribution License** (CC BY-NC-ND 3.0) which permits unrestricted use, distribution, and reproduction in any medium, provided the original work is properly cited. All rights reserved.

### ABSTRACT

We have isolated one novel nitrogen fixing bacteria, and it was biochemically identified as *Azotobacter vinelandii* and we named it as *Azotobacter vinelandii* SINAz1. The 16s rRNA was isolated and the sequence was submitted to NCBI data base and got the Accession number as MN135308.1. The presence of *nif D*, *nif K* and *nif H* gene was studied by PCR amplification. The nitrogen fixing efficiency of these bacteria was studied in laboratory by acetylene reduction assay (ARA) and also by pot culture experiments. The plant growth promoting (PGP) activities also studied by isolating and estimating the secretion of hormones like IAA, GA3, ABA and zeatin. These bacteria also provide salinity stress (200 mM NaCl) tolerance to rice plant for 15 days as compared with the control. The phenotypic growth and yield of rice crop by the application of these bacteria was studied which found to be significantly better than the control. This novel bacterium can be used as a substitute for the chemically synthesized nitrogen fertilizer for better productivity under normal as well as salinity stress condition.

**Keywords:** Azotobacter, Nitrogen, Biofertilizer, Rice, Nitrogen fixation.

### INTRODUCTION

The World population is increasing very fast and it will reach around 9 billion by 2050 (Godfrey *et al.*, 2010). To feed this huge population, food supplies will be increased upto 70-100 % (Tillman *et al.*, 2011). Rice is a very important crop, which is cultivated and consumed by maximum number of world population than other crop (Huang *et al.*, 2018). Besides that, rice cultivation provides much of the raw materials needed by today's manufacturing industry (Kenmore, 2003). Thus, rice production directly affects as well as the food security and on the economy of the population. Therefore, the production of rice must be increased to fulfil the requirements of coming world

18642



**Ranjan Kumar Sahoo and Madhusmita Pradhan**

population. Rice production depends mainly on nitrogen (N) fertilizer and chemical fertilizers intrinsically reduce fertilizer use efficiency of the crops, and degrade soil environment and environmental health through emission of nitrogen oxides, (especially  $N_2O$ ) from the anaerobic (flooded) rice ecologies (Bhattacharjee *et al.*, 2008). Therefore, biological (especially associative) nitrogen fixation (BNF) should be exploited to supplement N for rice production which would supplement 20–25% of the total N i.e. about 80000 tones atmospheric N/ha (Subba Rao, 2007). *Azotobacter* is generally regarded as a free-living aerobic nitrogen-fixer (Saharan and Nehra, 2011). Besides, nitrogen fixation, *Azotobacter* also protects plant through production of thiamine, riboflavin, Indole acetic acid (IAA) and Gibberellins (GA) (Sahoo *et al.*, 2012).

In this study, we report the discovery of novel nitrogen fixing free living bacteria *Azotobacter vinelandii* strain *SINAZ1* among 20 rhizospheric bacteria from different locations of Odisha, India. Along with nitrogen fixation, it secretes plant growth promoting hormones like IAA, GA3, ABA and zeatin significantly compared to other. It also protects rice plants from the toxic effect of salinity stress (200 mM NaCl) up to 15 days in pot experiments. This strain notably increased the growth and yield of rice plant without application of any chemical fertilizer. So our bacterium is novel and bears unique characteristics collectively nitrogen fixation, hormone secretion and salinity stress tolerance.

## MATERIALS AND METHODS

### Sites for pot experiments

The pot experiments were conducted in the net house of Department of Soil Science and Agricultural Chemistry, Orissa University of Agriculture and Technology, Odisha, India, in the year 2018-2019, to unveil the native efficient *Azotobacter* strain for formulation and production of potent indigenous biofertilizer for commercial exploitation in salinity soil.

### Isolation of nitrogen fixing organisms

For isolation of tentative *Azotobacter* species, soil samples were collected from four different rice fields situated in different locations of Odisha, India, viz. OUAT experimental field 1 and 2, Experimental field of Mahanga and Sindhupur, Cuttack, Odisha, India, where rice is cultivated at least for last 20 years. The rice plants (*Oryza sativa* L. var. IR64) were up rooted and the soil was scrapped off from the root and used for isolation. The isolates were phenotyped (Kennedy *et al.*, 2005; Sahoo *et al.*, 2014) grouped on the basis of phenotypic characters and one representative of each group of isolates were used for the remainder experiments.

### Morphological and staining characteristics of the bacteria

Morphological characteristics viz., shape, size, motility, Gram's stain of the bacteria were checked under a phase contrast light microscope (100X objective). Bacterial isolates were allowed to grow in nutrient broth (NB= NA without agar) for 8-12 h, diluted (in autoclaved distilled water) cultures were smeared respectively on slides and observed under a microscope. Gram's stain and spore stain (malachite green) of the isolates were done following standard microbial methods (Collee and Miles, 1989).

### Physiological and biochemical characterization of isolates

Various physiological and biochemical tests (oxidase, catalase, urease, indole production, methyl red, acetoin production, nitrate reduction, citrate utilization, hydrogen sulphide ( $H_2S$ ) production, carbohydrate fermentation, arginine dihydrolase, starch hydrolysis, lipase, tributyrin and vegetable oil hydrolysis, cholesterol hydrolysis, protein hydrolysis, gelatine and casein hydrolysis, pectin and chitin hydrolysis, lecithin hydrolysis) were done for



**Ranjan Kumar Sahoo and Madhusmita Pradhan**

identification of all the bacterial isolates. The detailed procedure of each test was performed according to the method described by Sahoo *et al.*, 2014.

***In vitro* nitrogen fixation by acetylene reduction assay (ARA), quantification of IAA, GA3 and ABA, zeatin produced by bacterial isolates.**

Nitrogen fixation efficiency in culture by the four *Azotobacter* isolates were assessed by ARA in the laboratory (Hardy *et al.*, 1968) cultivated on N-free Jensen agar (Jensen, 1954). The extraction and quantification of IAA, GA3, ABA and zeatin were done according to the method described earlier (Sahoo *et al.*, 2014).

**Amplification of *nifK*, *nifD*, *nifH* gene**

The genomic DNA was amplified using full length *nif K* primers (forward 5'- ATGAGCCAGCAAGTCGATAA-3' and reverse 5'- TGGTGCTGGACCATGCGATT-3'), *nif D* primers (forward 5'- ATGACCGGTATGTCGCGCCA-3' and reverse 5'- CGGCGGTGCGGACT-3') and *nifH* primers (forward 5'- ATGGCTATGCGTCAATGCGC-3' and reverse 5'- TCAGACTTCTTCGGCGGTTT-3') designed by using primer-3software.

**Preparation of biofertilizers**

Biofertilizers of the native rhizospheric *Azotobacter* spp. were formulated aseptically under a laminar air flow comprising of (g/kg) sterile (autoclaved) charcoal powder 700, CaCO<sub>3</sub> 100, gum acacia 20 and liquid culture 180 (180 ml containing 10<sup>9</sup> cfu/ml) i.e. final population 2 x 10<sup>8</sup> cfu/g formulation (according to Bureau of Indian Standards (BIS): in biofertilizers diazotrophs count (cfu/g formulation) initial 10<sup>8</sup>, 10<sup>7</sup> after 15 d and 10<sup>6</sup> 15 d before expiry of 6 mo).

**Treatment of seedlings and design of pot experiments**

Healthy, 21d old rice (*Oryza sativa* L. var. IR 64, a salt sensitive variety) seedling were dipped separately in biofertilizer suspensions (10% w/v i.e. 2 x 10<sup>8</sup>cfu/ml) for 2 h as recommended for commercial formulations by Bureau of Indian Standards (BIS) and transplanted in different pots with three replications each viz. Control (C) without any fertilizer; Treatment 1 (T1) with *Azotobacter vinelandii*. Isolated from OUAT experimental field 1; Treatment 2 (T2) with *Azotobacter vinelandii*. isolated from OUAT experimental field 2; Treatment 3 (T3) with *Azotobacter vinelandii*. isolated from experimental field Sindhupur, Cuttack.

**Growth parameters**

Growth parameters like plant height (cm), tiller/hill (no), effective tiller/hill (no), panicle length (cm), leaf area (sq. cm) and panicle length (cm) were measure prior to harvest. The crop was harvested after 90d and the post harvest observations like root length (cm), root dr. wt. (g), root volume (ml), panicle weight (g), grain yield/plant (g), filled grain/panicle (no.) and 1000 grain wt. (g) were recorded.

**Salinity stress tolerance assays**

The above pot experiments were repeated for salinity stress tolerance assay. The 3 selected *Azotobacter vinelandii* (Based on the ARA assay) strains along with control were used for these studies. The treatments (C, T1, T2 and T3) were used for this salinity tolerance assay. Rice plants after 6 weeks in soil were subjected to salinity (200 mM NaCl) stress. All the pots (C, T1, T2 and T3) were kept in one big tank filled with 200 mM NaCl solution. The plants were grown in the green house and the white light was provided (16 h photo period) by white fluorescent tubes (36 W Philips TLD) with a photon flux density of 52 μ /m<sup>2</sup>s (PAR).



**Ranjan Kumar Sahoo and Madhusmita Pradhan****16S rRNA gene sequencing**

The 16s rRNA gene was PCR amplified by using the forward (5'- AGAGTTTGATCMTGGCTCAG-3') and reverse primer 5'- GTTACCTTGTTACGACTTAAGTCGTAACAAGGTAACC-3 using the genomic DNA isolated from the most efficient *Azotobacter vinelandii*. The amplified products were sequenced and submitted to NCBI gene bank.

**Statistical analysis**

All statistical analysis were performed using the graph and prism software. The experimental data values were mean values from three independent series, each done with three replicates, and the results presented as means  $\pm$  standard error (SE), based on three replications. The statistical significance at  $P < 0.05$  has been calculated.

**RESULTS****Morphological, Colony and Biochemical characteristics of tentative *Azotobacter* on Jensen's media**

Tentative *Azotobacter* spp. isolated from different soil rhizosphere of different locations described above. Five types of soil bacteria (tentative *Azotobacter* spp.) isolated from each experimental rice fields using Jensen's medium (n=20). The organisms were phenotyped by their colony characters (Table 1). The colonies of the bacteria of Jensen's medium produced convex, circular, fluorescent, brown, off white or white, low convex, flat, plicate, size ranges from 0.60-1.00 mm, gummy, not gummy, mucoid (Table 1). Morphological characteristics viz., shape, size (length and breadth) motility, Gram's stain of the bacteria were checked under a phase contrast microscope (100X objective). The morphological characteristics of all 20 colonies were presented in Table 2.

**Biochemical characterization and antibiotic sensitivity**

The biochemical tests such as oxidase test, phosphatase test, nitrate reduction test catalase, carbohydrate utilization, carbohydrate fermentation, nitrate reduction, citrate utilization etc. were carried out for identification of isolates. The isolates were examined for catalase, oxidase and for urease test. In citrate utilization test, the bacteria of Jensen's medium showed positive some of them showed negative. Biochemical characterization of all isolates were given in the Table 3.

**Identification of *Azotobacter* spp.**

After biochemical tests some of them are identified as *Azotobacter vinelandii*, *Azotobacter chroococcum*, *Klebsiella* spp. *Beijerinckia* spp. *Pseudomonas* spp. from the 20 number of isolates (Table 4). The identified *Azotobacter vinelandii* were used for further assays.

**Acetylene reduction assay (ARA) of isolated *Azotobacter* spp.**

*In vitro* nitrogen fixing efficiency of identified *Azotobacter* spp. were studied and among the 11 isolates, the *Azotobacter vinelandii* isolated and identified from the different fields showed higher nitrogen fixation efficiency (Table 5). All the 3 *Azotobacter vinelandii* isolates (Az1a, Az2b and Az4a) identified from different fields were used in 3 treatments (T1, T2 and T3) respectively along with control (C) for further studies. Because these three *Azotobacter vinelandii* isolates have higher nitrogenise activity than others.



**Ranjan Kumar Sahoo and Madhusmita Pradhan****PGP functions of the *Azotobacter* isolates**

Plant growth promotion (PGP) functions of the *Azotobacter vinelandii* isolates (Az1a, Az2b and Az4a) were presented in Fig. 1. The activities were highly variable. The isolate Az4a possess higher IAA, ABA, GA3 and zeatin content than other two (Az1a and Az2b).

**Amplification of *nif* gene clusters**

The gene expected size (1.4kb) was obtained in gel picture of *nif D* gene, size of (1.5 kb) band was obtained in case of *nif K* gene and size of 0.87 kb was obtained in case of *nif H* gene for all the *Azotobacter* isolates (Fig. 2).

**16S rRNA sequencing of *Azotobacter vinelandii* isolate**

The amplified fragment of 16s rRNA of *Azotobacter vinelandii* (Az4a) was sequenced and the sequence was submitted to NCBI gene bank and catalogued the accession number as **MN135308.1**

**Growth observations in pot experiments under salinity stress.**

Effects of the the 3 *Azotobacter vinelandii* isolates (Az1a, Az2b and Az4a) on the growth and productivity of the rice plant along with control (C) experiment were studied. The control plants (C) were died and the plants of other treatments (T1, T2 and T3) were grew well and showed better phenotypic growth characteristics. Among them more tiller number, more plant height were observed in case of T3 (Fig. 3, Table 6).

***Azotobacter vinelandii* provide salinity (200 mM) tolerance to plants**

There was a significant difference in survival and agronomic parameters of rice plants of 3 different treatments (T3-T6) when compared with the plants of C. Better agronomic characteristics were observed in all the treatments under 200 mM salinity stress except C (Table 1). The rice plants of C pot died due to toxic stress of chromium. But other treatment (T1, T2 and T3) plants survived up to maturity.

**DISCUSSION**

All together 20 tentative *Azotobacter* spp. were isolated from Jensen's N-free medium and they were phenotyped by morpho-physiological and biochemical characters (Kennedy *et al.*, 2005; Sahoo *et al.*, 2014). The morphological, physiological and biochemical characters identified the isolates viz. Az1a, Az2b, Az4a as *Azotobacter vinelandii*, Az1b, Az2c, Az2d, Az3b, Az3d, Az3e, Az4e as *Azotobacter chroococcum*, and Az3a as *Azotobacter* spp. (Hill and Sawers, 2009) and the species of other isolates remained unknown. The results proved that the population of *Azotobacter* spp. of rice rhizosphere was diverse. Similarly, diverse species of *Azotobacter* i.e. *A. vinelandii*, *chroococcum* etc. were identified from rice rhizosphere elsewhere (Saharan and Nehra, 2011). Nitrogen fixation efficiency (acetylene reduction assay, ARA) of the *Azotobacter* spp. varied between 26.16-128.57 nmole C<sub>2</sub>H<sub>4</sub>/mg bact./h. The *Azotobacter vinelandii* SINAz1 (isolate no. Az4a) of experimental field Sindhupur, Cuttack which produced 128.57 nmole C<sub>2</sub>H<sub>4</sub>/mg bact./h, was more efficient nitrogen fixing organism in culture than the other isolated bacteria. The results proved that nitrogen fixation efficiency of the *A. vinelandii* SINAz1 was superior to other indigenous BNFs viz. acetylene reduction by heterotrophic or endophytic *Azotobacter* spp. which fixed 79.6- 329.50 nmol C<sub>2</sub>H<sub>4</sub>/h/culture or 57-686 nmole C<sub>2</sub>H<sub>4</sub>/mg protein/h (Barua *et al.*, 2012). In rice, ARA of heterotrophic or endophytic *Azotobacter* spp. was 12.10-53.40 nmol C<sub>2</sub>H<sub>4</sub>/mg bact./h (Barua *et al.*, 2012) which conformed with the present study. The 16S rDNA of the most potent *A. vinelandii* (Az3) (other isolates were not done) produced an amplicon of 1.4 kbp size which conformed to that of the other *Azotobacter* spp. (Sahoo *et al.*, 2014). Plant hormones control plant growth and developmental and played a role





### Ranjan Kumar Sahoo and Madhusmita Pradhan

in adaptation to different stresses (Peleg and Blumwald, 2011). The gibberellic acids (GA3) mitigate plant from the negative effects of salinity (Qin *et al.*, 2011). The stress-induced production of cytokinin in plants confers tolerance to transgenic plants to stress (Ha *et al.*, 2012). In the present study, we reported higher GA3, zeatin and IAA in rice plants inoculated with *A. vinelandii* SINAz1. It has been reported that the root and shoot biomass was increased with improved tolerance to salinity in the presence of growth promoting microorganisms (Fan *et al.*, 2011). Our study agree with the similar report on *Azotobacter* inoculation on chickpea (*Cicer arietinum* L.). *Azotobacter* inoculation increases the growth and yield of chickpea under saline (5.8 dS m<sup>-1</sup>) arid condition (Abdiev *et al.*, 2019).

Thus, the conformity of the phenotypic and genetic pattern profiles confirmed the identity of the re-isolates as introduced *Azotobacter vinelandii* SINAz1. The results also proved that the introduced *Azotobacter* SINAz1 established in the experimental pots under salinity conditions and substantially survived up to harvest of the crop with improved yield compared to uninoculated plants.

## REFERENCES

1. Abdiev, A., Khaitov, B., Toderich, K., Park, K.W. (2019). Growth, nutrient uptake and yield parameters of chickpea (*Cicer arietinum* L.) enhance by *Rhizobium* and *Azotobacter* inoculations in saline soil. *Journal of Plant Nutrition*. 42: 2703-2714.
2. Barua, S., Tripathi, S., Chakraborty, A., Ghosh, S., Chakrabarti, K. (2012). Characterization and crop production efficiency of diazotrophic bacterial isolates from coastal saline soils. *Microbiological Research*. 167: 95 - 102.
3. Bhattacharjee, R.B., Singh, A., Mukhopadhyay, S.N. (2008). Use of nitrogen-fixing bacteria as biofertilizer for non-legumes: prospects and challenges. *Applied Microbiology and Biotechnology*. 80: 199–209.
4. Collee, J.G., Miles, P.S. (1989). Tests for identification of bacteria. In: Practical medical microbiology, Eds. Collee JG, Duguid JP, Fraser AG, Marmion BP. Churchill Livingstone, NY, USA, pp. 141-160.
5. Fan, L., Dalpé, Y., Fang, C., Dubé, C., Khanizadeh, S. (2011). Influence of arbuscular mycorrhizae on biomass and root morphology of selected strawberry cultivars under salinity stress. *Botany* 89:397-403.
6. Godfray, H.C.J., Beddington, J.R., Crute, I.R. (2010). Food security: The challenge of feeding 9 billion people. *Science*. 327:812-818.
7. Ha, S., Vankova, R., Yamaguchi-Shinozaki, K., Shinozaki, K., Tran, L.S. (2012). Cytokinins: metabolism and function in plant adaptation to environmental stresses. *Trends in Plant Science*. 17:172-179.
8. Hardy, R.W.F., Holsten, R.D., Jackson, E.K., Burns, R.C. (1968). The acetylene-ethylene assay for N<sub>2</sub> fixation: Laboratory and field evaluation. *Plant Physiology*. 43: 1185-1207.
9. Hill, S., Sawers, G. (2000) *Azotobacter*. In: Encyclopedia of microbiology, vol. 1A-C, ed. Lederberg J, Acad Press, NY, USA. pp. 359- 371.
10. Huang, M., Fan, L., Chen, J., Jiang, L., Zou, Y. (2018). Continuous applications of biochar to rice: Effects on nitrogen uptake and utilization. *Scientific Reports*. 8: 11461.
11. Jensen, H.L. (1954). The Azotobacteriaceae. *Bacteriol Rev* 18: 195–214.
12. Kenmore, P. (2003). Sustainable rice production, food security and enhanced livelihoods, in: Rice Science: Innovations and Impact for Livelihood, Beijing, China, pp. 27-34.
13. Kennedy, C., Rudnick, P., Mac Donald, M.L., Melton, T. (2005). Genus III. *Azotobacter*. In: Bergey's manual of systematic bacteriology, Vol 2B, eds Brenner DJ, Krieg NR, Staley JT. Springer, New York, USA. pp. 384-402.
14. Peleg, Z., Blumwald, E. (2011). Hormone balance and abiotic stress tolerance in crop plants. *Current Opinion Plant Biology*. 14:290-295.
15. Qin, F., Kodaira, K.S., Maruyama, K., Mizoi, J., Tran, L.S., Fujita, Y., Morimoto, K., Shinozaki, K., Yamaguchi-Shinozaki, K. (2011) SPINDLY, a negative regulator of gibberellic acid signaling, is involved in the plant abiotic stress response. *Plant Physiology*. 157:1900- 1913.
16. Saharan, B.S., Nehra, V. (2011). Plant growth promoting rhizobacteria: a critical review. *Life Sciences and Medical Research*. 21: 1-30.







**Ranjan Kumar Sahoo and Madhusmita Pradhan**

17. Sahoo, R.K., Ansari, M.W., Dangar, T.K., Mohanty, S., Tuteja, N. (2014). Phenotypic and molecular characterisation of efficient nitrogen-fixing *Azotobacter* strains from rice fields for crop improvement. *Protoplasma*. 251: 511-523.
18. Sahoo, R.K., Bhardwaj, D., Tuteja, N. (2012). Biofertilizers: a sustainable eco-friendly agricultural approach to crop improvement. In *Plant Acclimation to Environmental Stress*. Edited by Tuteja N, Gill SS. LLC 233 Spring Street, New York, 10013, USA: Springer Science plus Business Media; pp. 403–432.
19. Subba Rao, N.S. (2007). *Soil microorganisms and plant growth*. Oxford IBH publication, New Delhi.
20. Tilman, D., Balzer, C., Hill, J. (2011). Global food demand and the sustainable intensification of Agriculture. *Proceedings of the National Academy of Sciences of the United States of America*. 108:20260-20264.

**Table 1. Colony characteristics of the isolated tentative *Azotobacter* spp.**

OUAT: Orissa University of Agriculture and Technology, Odisha, India

Location	Isolate no.	Form	Colour	Elevation	Margin	Size (mm)	Consistency
OUAT experimental field-1	Az1a	Circular	Brown	Convex	Entire	0.60-0.75	Gummy
	Az1b	Circular	Fluorescent	Flat	Entire	0.85-0.90	Gummy
	Az1c	Circular	Brown	Convex	Entire	0.65-0.75	Mucoid
	Az1d	Circular	Off white	Convex	Entire	0.65-0.75	Not gummy
	Az1e	Circular	Fluorescent	Low convex	Entire	0.85-0.90	Not gummy
OUAT experimental field-2	Az2a	Circular	Brown	Convex	Entire	0.60-0.75	Mucoid
	Az2b	Circular	Brown	Convex	Entire	0.60-0.75	Gummy
	Az2c	Circular	Fluorescent	Convex	Entire	0.85-0.90	Gummy
	Az2d	Circular	Fluorescent	Flat	Entire	0.60-0.75	Gummy
	Az2e	Circular	Fluorescent	Flat	Entire	0.65-0.75	Not gummy
Experimental field of Mahanga, Cuttack	Az3a	Circular	White	Flat	Entire	0.95-1.00	Gummy
	Az3b	Circular	White	Convex	Entire	0.85-0.90	Gummy
	Az3c	Circular	Off white	Convex	Entire	0.65-0.75	Mucoid
	Az3d	Circular	Brown	Low convex	Entire	0.85-0.90	Gummy
	Az3e	Circular	White	Low convex	Entire	0.85-0.90	Not gummy
Experimental field of Sindhupur, Cuttack	Az4a	Circular	Brown	Convex	Entire	0.65-0.75	Gummy
	Az4b	Circular	Brown	Convex	Entire	0.85-0.90	Not gummy
	Az4c	Circular	Off white	Flat	Entire	0.60-0.75	Mucoid
	Az4d	Circular	White	Convex	Entire	0.60-0.75	Mucoid
	Az4e	Circular	Brown	Low convex	Entire	0.65-0.75	Gummy

**Table 2 . Morphological characteristics of the tentative *Azotobacter* isolated on Jensen's media**

Location	Isolate no.	Shape	Length			Breadth			Motility	Gram stain
			Range	Mean	SE	Range	Mean	SE		
OUAT experimental field-1	Az1a	Ovoid	1.0-2.0	1.5	0.024	0.75-1.0	0.87	0.043	+	-ve
	Az1b	Large ovoid	1.5-2.0	1.75	0.021	0.5-1.0	0.75	0.027	+	-ve
	Az1c	Rod	1.5-2.0	1.75	0.025	0.5-0.75	0.62	0.036	+	-ve
	Az1d	Rod	1.5-2.0	1.75	0.031	0.5-0.75	0.62	0.027	-	-ve
	Az1e	Large ovoid	1.0-2.0	1.5	0.038	0.5-0.75	0.62	0.024	+	-ve





**Ranjan Kumar Sahoo and Madhusmita Pradhan**

OUAT experimental field-2	Az2a	Large ovoid	1.5-2.0	1.75	0.032	0.75-1.0	0.87	0.018	+	-ve
	Az2b	Ovoid	1.0-1.75	1.4	0.035	0.75-1.0	0.87	0.029	-	-ve
	Az2c	Rod	0.5-1.3	0.9	0.021	0.5-0.75	0.62	0.031	-	-ve
	Az2d	Rod	0.5-1.0	0.75	0.026	0.75-1.0	0.87	0.027	+	-ve
	Az2e	Large ovoid	1.0-2.0	1.5	0.031	0.5-0.75	0.62	0.018	+	-ve
Experimental field of Mahanga, Cuttack	Az3a	Ovoid	1.5-2.0	1.75	0.035	0.75-1.0	0.87	0.027	+	-ve
	Az3b	Ovoid	1.0-1.75	1.4	0.027	0.75-1.0	0.87	0.031	+	-ve
	Az3c	Rod	0.5-1.5	1.0	0.023	0.5-1.0	0.75	0.057	-	-ve
	Az3d	Rod	0.5-1.0	0.75	0.053	0.5-1.0	0.75	0.058	-	-ve
	Az3e	Ovoid	0.5-1.3	0.9	0.057	0.75-1.0	0.87	0.053	-	-ve
Experimental field of Sindhupur, Cuttack	Az4a	Rod	0.5-1.0	0.75	0.028	0.5-1.0	0.75	0.041	+	-ve
	Az4b	Ovoid	1.5-2.0	1.75	0.027	0.5-1.0	0.75	0.037	+	-ve
	Az4c	Ovoid	1.0-1.75	1.4	0.025	0.75-1.0	0.87	0.034	-	-ve
	Az4d	Ovoid	1.0-1.75	1.4	0.027	0.5-1.0	0.75	0.037	-	-ve
	Az4e	Ovoid	0.5-1.0	0.75	0.021	0.75-1.0	0.87	0.031	-	-ve

**Table 3. Biochemical characteristics of the tentative Azotobacter spp. isolated**

Name of test	OUAT experimental field-1					OUAT experimental field-2					Experimental field of Mahanga, Cuttack					Experimental field of Sindhupur, Cuttack				
	Az1a	Az1b	Az1c	Az1d	Az1e	Az2a	Az2b	Az2c	Az2d	Az2e	Az3a	Az3b	Az3c	Az3d	Az3e	Az4a	Az4b	Az4c	Az4d	Az4e
Oxidase	+	+	+	+	+	+	+	+	+	+	+	+	+	+	+	+	+	+	+	+
Phosphatase	+	+	+	+	+	+	+	+	+	+	+	+	+	+	+	+	+	+	+	+
Utilization of carbon source																				
Rhamnose	+	+	-	-	+	-	+	+	-	+	+	-	-	+	-	+	+	-	+	-
Caprylate	+	+	+	+	+	-	+	-	-	-	-	+	+	+	+	+	+	-	+	-
Meso-inositol	+	+	+	-	-	-	+	-	-	-	-	-	-	+	+	+	+	+	+	-
Mannitol	+	+	-	-	-	+	+	+	+	+	+	+	-	+	+	+	+	+	+	+
NO <sub>3</sub> reaction test	+	+	-	-	-	+	+	+	+	-	-	-	-	+	+	+	+	+	-	+
H <sub>2</sub> S production	+	+	-	-	+	+	+	-	-	-	+	+	-	+	+	+	+	+	-	+
Utilization of sole carbon source																				
Fructose	+	+	+	+	+	+	+	+	+	+	+	+	+	+	+	+	+	+	+	
Sucrose	+	+	+	+	+	+	+	+	+	+	+	+	+	+	+	+	+	+	+	
Glucose	+	+	+	+	+	+	+	+	+	+	+	+	+	+	+	+	+	+	+	
Glutarate	+	+	-	-	-	-	+	+	+	+	+	+	+	-	+	+	-	-	-	
Oxaloacetate	+	+	+	+	-	-	+	+	+	+	+	+	+	-	+	-	+	+	-	
D-galactose	+	+	-	-	+	+	+	+	+	+	+	+	+	+	+	+	+	+	+	
Glycerol	+	+	+	-	+	+	+	+	-	+	+	-	-	-	+	-	-	-	-	

**Table 4. Identification of tentative Azotobacter spp**

Location	Isolate No	Name of bacteria
OUAT experimental field-1	Az1a	<i>Azotobacter vinelandii</i>
	Az1b	<i>Azotobacter chroococcum</i>
	Az1c	<i>Pseudomonas</i>
	Az1d	<i>Klebsiella spp.</i>
	Az1e	<i>Beijerinckia</i>
OUAT experimental field-2	Az2a	<i>Klebsiella spp.</i>
	Az2b	<i>Azotobacter vinelandii</i>
	Az2c	<i>Azotobacter chroococcum</i>
	Az2d	<i>Azotobacter chroococcum</i>
	Az2e	<i>Klebsiella spp.</i>





## Ranjan Kumar Sahoo and Madhusmita Pradhan

Experimental field of Mahanga, Cuttack	Az3a	<i>Azotobacter spp.</i>
	Az3b	<i>Azotobacter chroococcum</i>
	Az3c	<i>Beijerinckia spp.</i>
	Az3d	<i>Azotobacter chroococcum</i>
	Az3e	<i>Azotobacter chroococcum</i>
Experimental field of Sindhupur, Cuttack	Az4a	<i>Azotobacter vinelandii</i>
	Az4b	<i>Pseudomonas spp.</i>
	Az4c	<i>Klebsiella spp.</i>
	Az4d	<i>Beijerinckia spp.</i>
	Az4e	<i>Azotobacter chroococcum</i>

Table 5. Nitrogen fixation efficiency (Acetylene reduction assay) by *Azotobacter* isolates

Field	Isolate no.	Organism	N <sub>2</sub> -ase activity (nmole C <sub>2</sub> H <sub>4</sub> /mg bact./h)
OUAT experimental field 1	Az1a	<i>Azotobacter vinelandii</i>	87.53 ± 3.09
	Az1b	<i>Azotobacter chroococcum</i>	69.19 ± 1.38
OUAT experimental field 2	Az2b	<i>Azotobacter vinelandii</i>	87.27 ± 2.16
	Az2c	<i>Azotobacter chroococcum</i>	84.53 ± 2.78
	Az2d	<i>Azotobacter chroococcum</i>	63.11 ± 4.23
Experimental field Mahanga, Cuttack	Az3a	<i>Azotobacter spp.</i>	63.68 ± 2.11
	Az3b	<i>Azotobacter chroococcum</i>	58.12 ± 4.78
	Az3d	<i>Azotobacter chroococcum</i>	45.38 ± 4.11
	Az3e	<i>Azotobacter chroococcum</i>	76.11 ± 2.58
Experimental field Sindhupur, Cuttack	Az4a	<i>Azotobacter vinelandii</i>	128.57 ± 2.13
	Az4e	<i>Azotobacter chroococcum</i>	26.16 ± 1.22
CD, P 0.05	—		11.98

Table 6: Phenotypic growth characteristics (plant height, root length, root dry weight, leaf area); photosynthetic characteristics (chlorophyll content, net photosynthetic rate, stomatal conductance, and internal CO<sub>2</sub> concentration, total protein); nutrient content (nitrogen, phosphorus, potassium, sodium) of rice plants at different treatments (Az1, Az2, Az3) and control (C) after 15 days salinity (200 mM) stress

Attributes	C (Control)	Az1	Az2	Az3
Plant height (cm)	61±2.0 <sup>c</sup>	75±3.1 <sup>a</sup>	75±3.2 <sup>a</sup>	79±3.0 <sup>b</sup>
Root length (cm)	20±1.1 <sup>b</sup>	30±1.2 <sup>a</sup>	30±0.8 <sup>a</sup>	30±1.0 <sup>a</sup>
Root dry weight (g)	1.9±0.11 <sup>b</sup>	2.5±0.1 <sup>a</sup>	2.4±0.12 <sup>a</sup>	2.7±0.1 <sup>a</sup>
Leaf area (cm <sup>2</sup> /plant)	74±1.0 <sup>c</sup>	87±1.5 <sup>a</sup>	91±2.1 <sup>a</sup>	91±1.5 <sup>b</sup>
Total chlorophyll (mg/g f wt)	6.62±0.4 <sup>b</sup>	9.12±0.1 <sup>a</sup>	9.02±0.21 <sup>a</sup>	9.11±0.3 <sup>a</sup>
Total protein (mg/g f wt)	1.51±0.82 <sup>b</sup>	1.72±0.81 <sup>a</sup>	1.71±0.52 <sup>a</sup>	1.72±0.51 <sup>a</sup>
Net photosynthetic rate (P <sub>N</sub> , μ mol CO <sub>2</sub> m <sup>-2</sup> s <sup>-1</sup> )	6.01±0.3 <sup>b</sup>	9.10±0.1 <sup>a</sup>	9.21±0.2 <sup>a</sup>	9.05±0.3 <sup>a</sup>
Stomatal conductance (gs, m mol m <sup>-2</sup> s <sup>-1</sup> )	211±10.5 <sup>c</sup>	243±9.3 <sup>a</sup>	242±10.4 <sup>a</sup>	245±10.2 <sup>b</sup>
Intracellular CO <sub>2</sub> (C <sub>i</sub> , μ mol mol <sup>-1</sup> )	212±9.5 <sup>b</sup>	221±10.4 <sup>a</sup>	221±10.2 <sup>a</sup>	225±10.1 <sup>a</sup>
Nitrogen (%)	0.253±0.011 <sup>c</sup>	0.274±0.011 <sup>a</sup>	0.275±0.010 <sup>a</sup>	0.279±0.011 <sup>b</sup>
Phosphorus (%)	0.219±0.010 <sup>b</sup>	0.241±0.011 <sup>a</sup>	0.242±0.010 <sup>a</sup>	0.241±0.011 <sup>a</sup>
Potassium (%)	0.123±0.001 <sup>b</sup>	0.163±0.002 <sup>a</sup>	0.165±0.003 <sup>a</sup>	0.163±0.001 <sup>a</sup>
Sodium (%)	0.042±0.001 <sup>a</sup>	0.042±0.001 <sup>a</sup>	0.041±0.001 <sup>a</sup>	0.042±0.001 <sup>a</sup>





Ranjan Kumar Sahoo and Madhusmita Pradhan

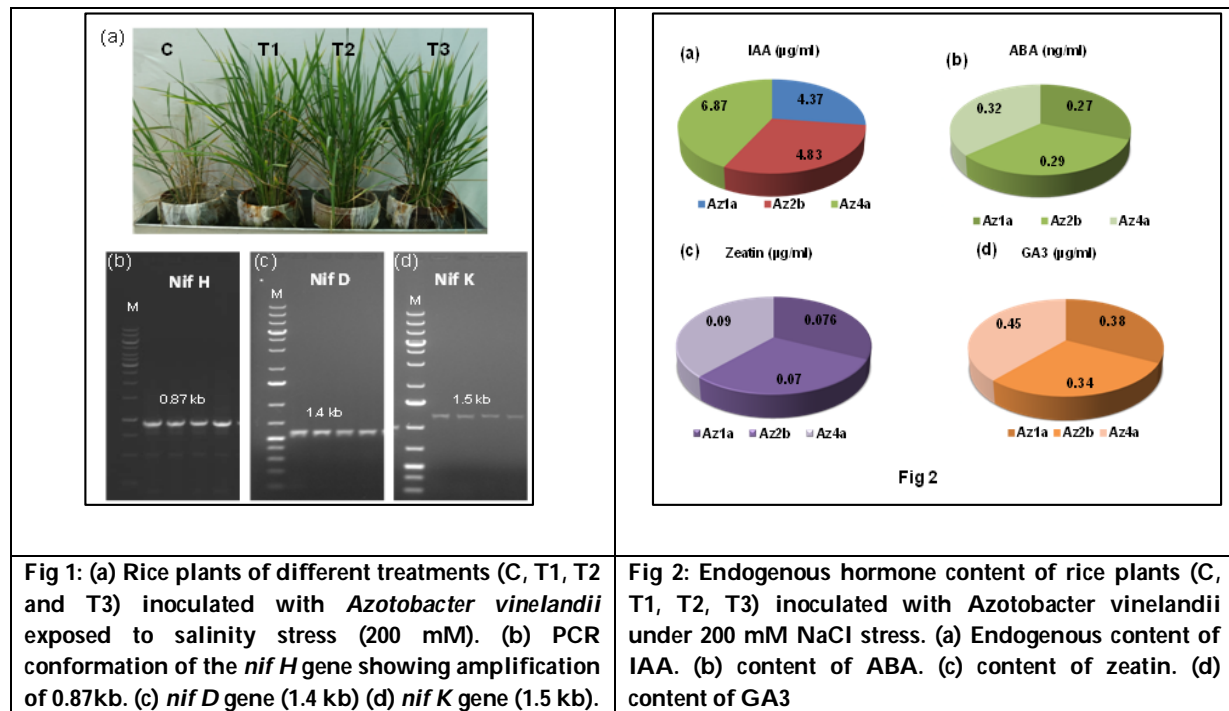



## Comparative Analysis of Age and Growth of Fresh Water Fishes (*Labeo rohita*, *Cirrhinu smrigala* and *Puntius ticto*)

Sunita Panda, Soumen Mohanty and Pradip Kumar Prusty\*

Department of Zoology, School of Applied Sciences, Centurion University of Technology and Management, Odisha, India

Received: 13 Jan 2020

Revised: 17 Feb 2020

Accepted: 19 Mar 2020

### \*Address for Correspondence

#### Pradip Kumar Prusty

Department of Zoology,  
School of Applied Sciences,  
Centurion University of Technology and Management,  
Bhubaneswar, Odisha, India.  
Email: pradipkumar.prusty@cutm.ac.in



This is an Open Access Journal / article distributed under the terms of the **Creative Commons Attribution License** (CC BY-NC-ND 3.0) which permits unrestricted use, distribution, and reproduction in any medium, provided the original work is properly cited. All rights reserved.

### ABSTRACT

Age and growth study provide detail information on the life history, ecology of fish and habitat which is important to manage the water body for fish production and optimize of harvestable size. Scale based age and growth of Indian major carp (*Labeo rohita*, *Cirrhinus mrigala* and *Puntius ticto*) was studied. There is no significance occurs in between the species. Such study are helpful in describing the present status of fish population along with the future course of the fishery.

**Keywords:** Scale, Age determination, *Labeo rohita*, *Cirrhinus mrigala*, *Puntius ticto*.

## INTRODUCTION

Age and growth are closely linked. Determination of age is an age old practice. It is a rational part of the work direct to the exploitation of fish stock. (Begenal,1974; Mills and Beamish,1980 and Panfili. *et al.*,2002). Knowing the age of the fish provides clue to its longevity, age of first maturity, age recruitment and growth. (Summer felt and Hall,1987). Age and growth studies are important for the problem associated with management of fisheries. Age determination of fish from scale, otolith, vertebrate fins, spines, fin rays and other structure are usually performed. Monitoring of fish population of known age and require for long time and is quite expensive method. Hence the best appropriate method for age determination is to study of annulus formation of fish (Secor et al., 1996).

The age of fish can be estimated indirectly the length frequency distribution. From which it can obtain the mean length of each age group or directly by counting and analysis of the annual growth marks in calcified structure such as scale, otolith, opercular bone and fin rays of each specimen ( Bhatt and Jahan, 2015). Age determination in fish can



**Sunita Panda et al.**

be carried out using anatomical method, length frequency analysis or direct measurement. The study of weight length has the great value in fisheries and. Significantly is to access the growth of fish in different environment. Some authors describe the length weight relationship in various fish scale and age , (Naeem et al., 1992). Age determination in fish is fundamental for the management of fisheries ( Hilborn and Walters 2013) .Age determination of fish is useful for understanding fish life history and their population dynamics (Beddington and Kirkwood 2005).The many body parts of fish that is scales, opercula, vertebrae,spines, fin rays and otoliths (Casselman 1983),are available for ageing fish,and these structure are used for comparative purposes (Vilizzi and Walker 1999: khan and khan 2009). In India 31 species of *Labeo rohita* were found. (Talwar and jhingran 1991).Labeorohita (Hamilton,1882) commonly known as Rohu is the one of the most commercially important fresh water fishes. It belongs to the family Cyprinidae and order Cypriniformes. It is found in all tanks and ponds.( Beavan,1877). It occurs widely in the Northeast, Northern and central India: Nepal and Pakistan.(Talwar and Jhingran,1991).Labeorohita are typically full scaled and silvery, black grey, olive green or yellow-brownish coloured.(Kirpichnikov 1967, Balon 1995, Lintermans 2007).The fish is covered with cycloid scale.(Hamilton,1882).

*Cirrhinus mrigala* (Hamilton,1882) commonly known as Mrigala is a carp native to the river of Indo-Gangetic plains of India and Pakistan. It belongs to the family Cyprinidae and order Cypriniforms.(Hamilton,1882).Mrigala is typically full scaled and silvery grey or yellow brown in their backs, pale yellow or white on their bellies (Kirpichnikov, 1967; Balon 1995; Linterman 2007). In natural environment it grow in 99cm and weight is 12.7kg. It is a detritus and bottom feeder. (Talwar and Jhingran 1991).The body is covered with cycloid scale (Hamilton,1882). *Puntius ticto* (Hamilton, 1882) is a small indigenous fresh water and brackish water fish species. It is commonly known as 'ticto' and 'two-spot barb'. It is silvery in colour and two black spots are found on the lateral line and depth of body less than one-third of standard length.(Islam, 2007; Rahman, 2005 and Rahman,1989).The body is covered with cycloid scale. (Hamilton,1882).

## MATERIALS AND METHODS

The fresh water fishes *Labeo rohita*, *Cirrhinus mrigala* and *Puntius ticto* were purchased from local fish market (Jagatsinghpur) Odisha and total length of each fish was measured. The fish scale were scrubbed from the lateral side of the fish in the region directly below the dorsal fin and above the lateral line.Ten and twelve scales were taken from each fish and kept separated. Isolated scale were first washed in water and the scrubbed gently between finger tips to remove the mucus and other extraneous matter attached to the scale then they were cleared with tissue paper.To make scale more clear and soft, they were dipped in weak 1% of KOH solution for about 5min then washed with tap water and dried in air.The scale were place in 30%, 50% and 70% alcohol respectively for about 5min to dehydrate. Then they were stained with Eosin and washed with 70% alcohol.Again the scale were dehydrated with 90% alcohol for 5 minute. Finally the scale were placed over the slide. Covered with cover slips and observed under trinocular microscope (10x) and taken the photo of scale using both 10x and 5x lens.The number of complete annuli and rings were counted and noted down properly.

## RESULTS AND DISCUSSION

*Labeo rohita*, *Cirrhinus mrigala* and *Puntius ticto* (n=5) were collected from the local areas of Jagatsinghpur, Odisha. Their measurements were taken in cm, then mean and standard deviation of each species parameter were calculated and noted in the form of table-(1). There is no significance in between the species of *Labeo rohita*. In, ANOVA table of *Labeo rohita* between the group, sum of square is 160.213, df is 4, mean square is 40.0532,F is 0.338 and p<1.With in the group sum of square is 8887.65, df is 75, mean square is 118.502 and p<1.The total of sum of square is 9047.86 and df is 79.The mean of weight of 5 species of *Labeo rohita* is 644 where the age consisting of 1 and below 1 year.



**Sunita Panda et al.*****Cirrhinus mrigala***

The measurement of *Cirrhinus mrigala* were taken in cm, then mean and standard deviation of each species parameter were calculated and noted in the form of table(5). There is no significance in between the species of *C.mrigala*. In ANOVA table between the group the sum of square is 383.827, df is 4, mean square is 95.9567 and f is 0.5665 and  $p < 1$ . In within the group sum of square is 12703.8, df is 75, mean square is 169.383 and  $p < 1$ . The mean of weight of 5 species is 980 having age below 1 year.

***Puntius ticto***

The measurement of *puntiusticto* were taken in cm, the mean and standard deviation of each parameter were calculated and noted in the form of table (9). There is no significance in between the species of *puntius ticto*. In ANOVA table, between the group, the sum of square is 1.89825, df is 4, mean square is 0.474562 and F is 0.1236 and  $P < 1$ . In with in the group sum of square is 287.981, df is 75, mean square is 3.83975 and  $P < 1$ . The mean of weight of 5 species is 3.12 having age below 1 year.

**CONCLUSION**

The overall results indicates that *Labeo rohita*, *Cirrhinus mrigala*, *Puntius ticto* showed an almost isomeric pattern of growth in the present habitat and condition factor values showed that it is in good condition and economic viable for fisheries. The study will help biologists to know the status of this fish and developed culture technology in natural water and will be useful for the fisheries biologist and conservation biologists for successful development, management, production and ultimate conservation of the most preferred food fishes of the state.

**REFERENCES**

1. Bagenal, T. B. (Ed.). (1974). The Proceedings of an International Symposium on the Ageing of Fish: Sponsored by the European Inland Fisheries Advisory Commission of FAO, the Fisheries Society of the British Isles and the Freshwater Biological Association and Held at the University of Reading, England on 19 and 20 July 1973. Unwin Brothers Limited.
2. Bahuguna, P. (2013). Age determination and growth rate of freshwater fish *Puntius conchoni* (Ham.-Buch) by a use of trunk vertebrae. *Periodic Research*, 2, 46-51.
3. Beddington, J. R., & Kirkwood, G. P. (2005). The estimation of potential yield and stock status using life-history parameters. *Philosophical transactions of the royal society B: biological sciences*, 360(1453), 163-170.
4. Bhatt, B. J., & Jahan, N. (2015). Determination of age and growth rate of fresh water fish *Labeo rohita* (Ham. 1822) by using cycloid scales. *Int J Pure App Biosci*, 3(3), 189-200.
5. Casselman, J. M. (1983). Age and growth assessment of fish from their calcified structures—techniques and tools. NOAA Technical Report NMFS, 8, 1-17.
6. Das, S. P., Bej, D., Swain, S., Jena, J. K., & Das, P. Relative age and growth of Indian major carp, *Cirrhinus mrigala*, from peninsular rivers of India.
7. Hilborn, R., & Walters, C. J. (Eds.). (2013). Quantitative fisheries stock assessment: choice, dynamics and uncertainty. Springer Science & Business Media.
8. Jhingran, V. G. (1957). Age determination of the Indian major carp *Cirrhinamrigala* (Ham.) by means of scales. *Nature*, 179(4557), 468-469.
9. Johal, M. S., & Tandon, K. K. (1992). Age and growth of the carp *Catla catla* (Hamilton, 1822) from Northern India. *Fisheries research*, 14(1), 83-90.





**Sunita Panda et al.**

10. Khan, M. A., & Khan, S. (2009). Comparison of age estimates from scale, opercular bone, otolith, vertebrae and dorsal fin ray in *Labeo rohita* (Hamilton), *Catla catla* (Hamilton) and *Channa marulius* (Hamilton). Fisheries research, 100(3), 255-259.
11. Mills, K. H., & Beamish, R. J. (1980). Comparison of fin-ray and scale age determinations for lake white fish (*Coregonus clupea* form is) and their implications for estimates of growth and annual survival. Canadian journal of fisheries and aquatic sciences, 37(3), 534-544.
12. Summerfelt R. C. and Hall G. E. (eds.), (1987) Age and growth of fish. The Iowa state University Press, Ames, Iowa. 544
13. Vilizzi, L., & Walker, K. F. (1999). Age and growth of the common carp, *Cyprinus carpio*, in the River Murray, Australia: validation, consistency of age interpretation, and growth models. Environmental Biology of Fishes, 54(1), 77-106.

**Table 1: Calculated length, mean and standard deviation of *L. rohita***

Measurement	<i>Labeo rohita</i> -1 (in cm)	<i>Labeo rohita</i> -2 (in cm)	<i>Labeo rohita</i> -3 (in cm)	<i>Labeo rohita</i> -4 (in cm)	<i>Labeo rohita</i> -5 (in cm)	Mean	Standard deviation
Total length	38.1	40.2	30.1	42.2	35.2	37.16	± 4.224
Standard length	30.5	32.4	24.3	34.0	28.3	29.9	±3.386
Fork length	32.8	35.2	25.9	36.3	30.3	32.1	±3.726
Head length	7.8	8.23	6.16	8.64	7.21	7.60	±0.865
Pre-pelvic length	15	15.8	11.8	16.6	13.8	14.6	±1.678
Pre-dorsal length	14	14.7	11.0	15.5	12.9	13.6	±1.563
Dorsal fin base length	6	6.33	4.74	6.64	5.54	5.85	±0.664
Caudal depth	9	9.50	7.11	9.97	8.32	8.78	±0.998
Body depth	10	10.55	7.9	11.07	9.23	9.73	±1.107
Peduncle length	4	4.22	3.16	4.43	3.69	3.9	±0.443
Pre orbital length	2.5	2.64	1.97	2.74	2.30	2.43	±0.273
Eye diameter	10.1	10.6	7.98	11.19	9.46	9.8	±1.101
Post orbital length	6	6.33	4.74	6.64	5.54	5.85	±0.664
Pectoral length	5.8	6.12	4.58	6.43	5.36	5.6	±1.317
Pelvic fin base length	6	6.33	4.74	6.64	5.54	5.85	±0.664
Anal fin base length	5.8	6.12	4.58	6.43	5.36	5.6	±0.645
Species	Weight(gm)	Age					
<i>Labeorohita</i> -1	650	1					
<i>Labeorohita</i> -2	700	1					
<i>Labeo rohita</i> -3	500	Below 1					
<i>Labeo rohita</i> -4	750	Below 1					
<i>Labeo rohita</i> -5	620	Below 1					
Mean	644						

**Table 2: Age and Weight relationship**

	<i>L. rohita</i> -1	<i>L. rohita</i> -2	<i>L. rohita</i> -3	<i>L. rohita</i> -4	<i>L. rohita</i> -5
<i>L. rohita</i> -1					
<i>L. rohita</i> -2	0.99994				
<i>L. rohita</i> -3	0.99998	0.99993			
<i>L. rohita</i> -4	0.99999	0.99993	1		
<i>L. rohita</i> -5	0.99999	0.99993	0.99999	0.99999	







**Sunita Panda et al.**

**Table 4: Test for equal means (ANOVA) of *L.rohita***

	Sum of square	df	Mean square	F	p (same)
Between groups:	160.213	4	40.0532	0.338	0.8515
Within groups:	8887.65	75	118.502		Permutation p (n=99999) 0.8543
Total:	9047.86	79			

**Table 5: Calculated lengthmean and standard deviation of *C.mrigala***

Measurements	<i>Cirrhinus mrigala</i> -1 (in cm)	<i>Cirrhinus mrigala</i> -2 (in cm)	<i>Cirrhinus mrigala</i> -3 (in cm)	<i>Cirrhinus mrigala</i> -4 (in cm)	<i>Cirrhinus mrigala</i> -5 (in cm)	Mean	Standard deviation
Total length	48	43	46.2	32.1	30.5	39.96	±7.267
Standard length	41	36.7	39.4	27.4	26.0	34.1	±6.212
Fork length	41.2	31.6	39.8	27.6	26.2	33.28	±0.746
Head length	8.8	7.88	8.47	5.88	5.59	7.3	±1.333
Pre-pelvic length	22	19.7	21.1	14.7	13.9	18.28	±3.340
Pre-dorsal length	19.3	17.3	18.6	12.9	12.2	16.06	±2.945
Dorsal fin base length	8	7.16	7.7	5.35	5.08	6.65	±1.211
Caudal depth	5	4.47	4.81	3.34	2.10	3.94	±1.086
Body depth	11.6	10.4	11.1	7.77	7.38	9.65	±1.740
Peduncle length	5.3	4.75	5.10	3.54	3.55	4.44	±0.758
Pre orbital length	4	3.58	3.85	2.67	2.54	3.32	±0.606
Eye diameter	1	0	0.9	0.6	0.6	0.62	±0.348
Post orbital length	5	4.47	4.81	3.34	3.17	4.15	±0.758
Pectoral length	7.6	6.81	7.32	5.08	4.83	6.32	±1.152
Pelvic fin base length	1.5	1.34	1.29	1.0	0.9	1.2	±0.222
Anal fin base lengths	3.3	2.9	3.18	2.21	2.10	2.73	±0.494

**Table 6: Age and Weight relationship of *C.mrigala***

SPECIES	WEIGHT(g)	AGE
<i>Cirrhinus mrigala</i> -1	1300	Below 1 year
<i>Cirrhinus mrigala</i> -2	1100	Below 1 year
<i>Cirrhinus mrigala</i> -3	1150	Below 1 year
<i>Cirrhinus mrigala</i> -4	750	Below 1 year
<i>Cirrhinus mrigala</i> -5	600	Below 1 year
<b>mean</b>	890	





Sunita Panda et al.

**Table 7: Correlation of *Cirrhinus mrigala***

	<i>Cirrhinus mrigala</i> -1	<i>Cirrhinus mrigala</i> -2	<i>Cirrhinus mrigala</i> -3	<i>Cirrhinus mrigala</i> -4	<i>Cirrhinus mrigala</i> -5
<i>Cirrhinus mrigala</i> -1					
<i>Cirrhinus mrigala</i> -2	0.99592				
<i>Cirrhinus mrigala</i> -3	0.99999	0.9957			
<i>Cirrhinus mrigala</i> -4	1	0.99584	0.99999		
<i>Cirrhinus mrigala</i> -5	0.99962	0.99543	0.99961	0.99962	

**Table 8: Test for equal means (ANOVA) of *C. mrigala***

	Sum of square	df	Mean square	F	p (same)
Between groups:	383.827	4	95.9567	0.5665	0.6877
Within groups:	12703.8	75	169.383		Permutation p (n=99999) 0.6951
Total:	13087.6	79			

**Table 9: Calculated length, mean and standard deviation of *P. ticto***

Measurements	<i>Puntius ticto</i> -1 (in cm)	<i>Puntius ticto</i> -2 (in cm)	<i>Puntius ticto</i> -3 (in cm)	<i>Puntius ticto</i> -4 (in cm)	<i>Puntius ticto</i> -5 (in cm)	Mean	Standard deviation
Total length	6.6	5.2	5.9	6.2	5.0	5.78	±0.601
Standard length	6	4.7	5.3	5.6	4.5	5.22	±0.556
Fork length	5.3	4.1	5.0	5.1	4.1	4.72	±0.515
Head length	1.2	0.9	1.0	1.1	0.9	1.02	±0.116
Pre-pelvic length	2.7	2.1	2.4	2.5	2.0	2.34	±0.257
Pre-dorsal length	2.7	2.1	2.4	2.5	2.0	2.34	±0.257
Dorsal fin base length	0.5	0.3	0.4	0.4	0.3	0.38	±0.074
Caudal depth	0.7	0.5	0.6	1.6	0.5	0.78	±0.416
Body depth	1.7	1.3	1.5	1.5	1.3	1.46	±0.149
Peduncle length	0.5	0.3	0.4	0.4	0.3	0.38	±0.074
Pre orbital length	0.2	0.1	0.1	0.1	0.1	0.18	±0.046





Sunita Panda et al.

Eye diameter	0.2	0.1	0.1	0.1	3.8	0.86	±1.470
Post orbital length	0.5	0.3	0.2	0.4	0.3	0.34	±0.101
Pectoral length	0.7	0.5	0.4	0.6	0.5	0.54	±0.101
Pelvic fin base length	0.3	0.2	0.1	0.2	0.2	0.2	±0.063
Anal fin base length	0.5	0.3	0.2	0.1	0.3	0.28	±0.132

Table 10: Age and Weight relationship of *P.ticto*

SPECIES	WEIGHT(g)	AGE
<i>Puntius ticto</i> -1	3.75	Below 1 year
<i>Puntius ticto</i> -2	3.60	Below 1 year
<i>Puntius ticto</i> -3	2.70	Below 1 year
<i>Puntius ticto</i> -4	2.00	Below 1 year
<i>Puntius ticto</i> -5	3.55	Below 1 year
<b>Mean</b>	3.12	

Table 11: Correlation of *Puntius ticto*

	<i>Puntius ticto</i> -1	<i>Puntius ticto</i> -2	<i>Puntius ticto</i> -3	<i>Puntius ticto</i> -4	<i>Puntius ticto</i> -5
<i>Puntius ticto</i> -1					
<i>Puntius ticto</i> -2	0.9999				
<i>Puntius ticto</i> -3	0.99879	0.99858			
<i>Puntius ticto</i> -4	0.99155	0.99172	0.99277		
<i>Puntius ticto</i> -5	0.85347	0.85419	0.85613	0.84191	

Table 12: Test for equal means (ANOVA) of *P.ticto*

	Sum of square	df	Mean square	F	P (same)
Between groups:	1.89825	4	0.474562	0.1236	0.9736
Within groups:	287.981	75	3.83975		Permutation p (N=99999) 0.9744
Total:	289.88	79			

Table 13: Comparative morphometric data of *Labeo rohita*, *Cirrhinus mrigala* and *Puntius ticto*

Measurements	<i>Labeorohita</i>	<i>Cirrhinusmrigala</i>	<i>Puntiusticto</i>	Mean
Total length	37.16	39.96	5.78	±27.63
Standard length	29.9	34.1	5.22	±23.07
Fork length	32.1	33.28	4.72	±23.36
Head length	7.60	7.3	1.02	±5.30
Pre-pelvic length	14.6	18.28	2.34	±11.74
Pre-dorsal length	13.6	16.06	2.34	±10.66
Dorsal fin base length	5.85	6.65	0.38	±4.29
Caudal depth	8.78	3.94	0.78	±4.5

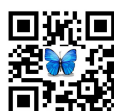



**Sunita Panda et al.**

Body depth	9.73	9.65	1.46	±6.94
Peduncle length	3.9	4.44	0.38	±6.90
Pre orbital length	2.43	3.32	0.18	±1.97
Eye diameter	9.8	0.62	0.86	±3.76
Post orbital length	5.85	4.15	0.34	±3.43
Pectoral length	5.6	6.32	0.54	±4.15
Pelvic fin base length	5.85	1.2	0.2	±2.41
Anal fin base length	5.6	2.73	0.28	±2.87

**Table 14: Correlation table of mean of 3 fish species**

	<i>Labeo rohita</i>	<i>Cirrhinus mrigala</i>	<i>Puntius ticto</i>
<i>Labeo rohita</i>			
<i>Cirrhinus mrigala</i>	0.96924		
<i>Puntius ticto</i>	0.98763	0.98627	

**Table 15: Test for equal means (ANOVA) of 3 fish species**

	Sum of square	df	Mean square	F	p (same)
Between groups:	1182.24	2	591.118	6.23	0.004087
Within groups:	4269.43	45	94.8763		Permutation p (n=99999) 0.00343
Total:	5451.67	47			

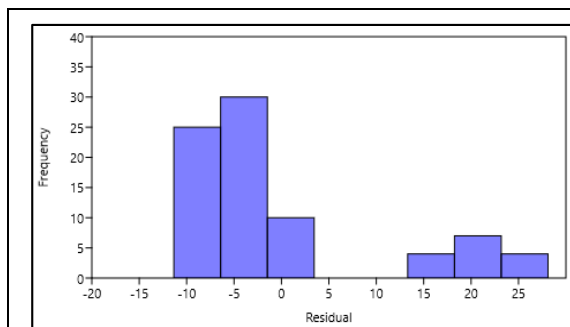

**Fig.1. Histogram of residuals of *Labeo rohita***

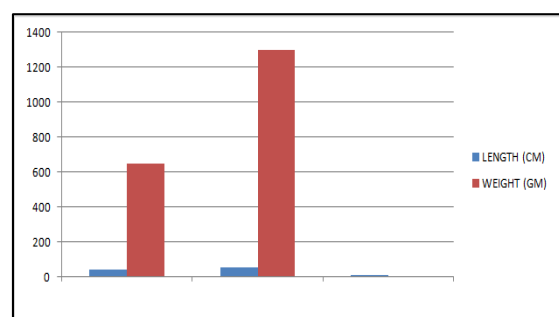

**Fig.2. Histogram of Length and weight**

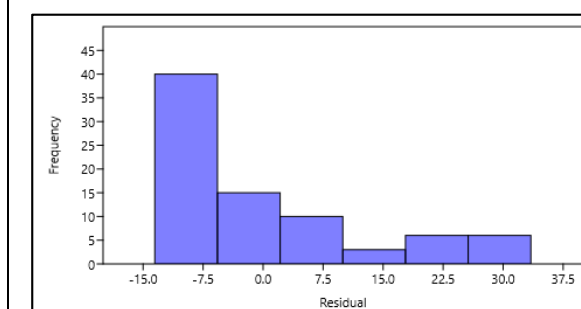

**Fig.3. Histogram of residuals of *Cirrhinus mrigala***

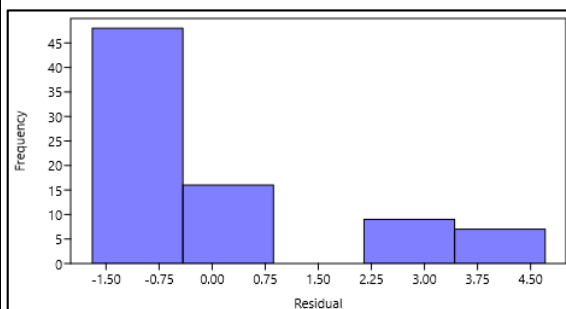

**Fig.4. Histogram table of residuals of *Puntius ticto***



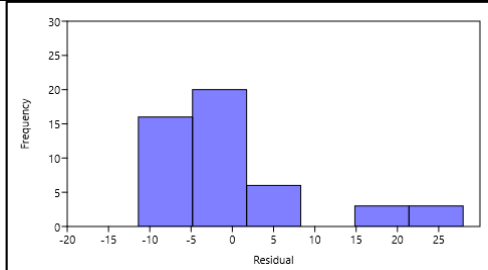

Fig.5.Histogram of residuals of 3 fish species



Fig.6 *Labeo rohita* length 38.1cm; weight 650gm

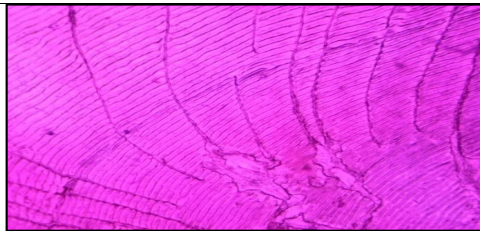

Fig.7 scale of *Labeo rohita*



Fig.8. *Puntius ticto* length 6.6cm; weight 3.75gm

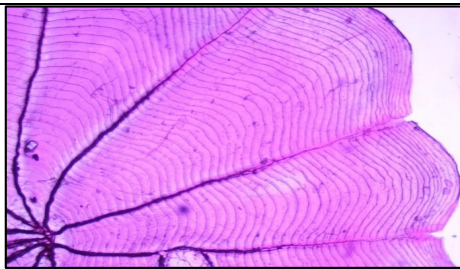

Fig.9.scale of *puntiu sticto*



Fig.10 *Cirrhinus mrigala* length 48cm; weight 1300gm

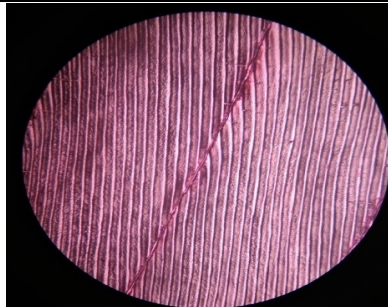

Fig.11.scale of *Cirrhinus mrigala*





## Antimicrobial, Phytochemical Analysis and Cytotoxic Screening of Ajwain

J.Joonu

Assistant Professor, Department of Zoology, Bishop Heber College, Trichy, Tamil Nadu, India.

Received: 18 Jan 2020

Revised: 20 Feb 2020

Accepted: 23 Mar 2020

### \*Address for Correspondence

J.Joonu

Assistant Professor,  
Department of Zoology,  
Bishop Heber College, Trichy,  
TamilNadu, India.  
Email: joonucharles@gmail.com



This is an Open Access Journal / article distributed under the terms of the **Creative Commons Attribution License** (CC BY-NC-ND 3.0) which permits unrestricted use, distribution, and reproduction in any medium, provided the original work is properly cited. All rights reserved.

### ABSTRACT

The present study deals with the analysis of phytochemical compounds, antimicrobial activity and cytotoxicity screening from the seeds extract of *Trachyspermum ammi* (Ajwain). In this study, two types of extract were prepared, Methanol and ethyl acetate extract. It was observed that the ethyl acetate extract was found to be more effective than the methanol extract. Three strains of bacteria *Bacillus spp.*, *Enterobacter spp.* and *Streptococcus spp.* were isolated from the soil. Among these three bacteria, *Enterobacter spp.* shows a weak sensitive against the Ajwain compared to the other bacteria, showing a large zone of inhibition. The antibacterial assays of the nutrient broth of both the extracts (Methanol and ethyl acetate) were calculated. Correlation and ANOVA were done on the OD values obtained from the antibacterial assay. The result shows that the correlation is significant and hence accepts the null hypothesis. Cytotoxic screening was done on earthworm using the extract of Ajwain (*Trachyspermum ammi*). There was a significant decrease in the liver enzymes which prevents liver cirrhosis and liver damage. HPLC results shows the presence of Quercetin, flavonoids, diterpenoids, and Quinone.

**Keywords:** Phytochemical compounds, Ajwain, Correlation, ANOVA, cytotoxicity, Quercetin, flavonoids, diterpenoids, and Quinone

### INTRODUCTION

Ajwain (*Trachyspermum ammi*) which belongs to Apiaceae is a plant growing in India, Pakistan, South East and Near East of Iran. It is distributed throughout in India, and it is mostly cultivated in Gujarat and Rajasthan, where the seeds are used as a spice.



**Joonu****Antimicrobial actions *In vitro***

The thymol is the active compound present in Ajwain which has the antimicrobial effect. Thymol compound can lyse the bacteria which are found to be resistant third generations antibiotics and multi-drugs resistant microbial pathogens. It can be used as a plant based 4<sup>th</sup> generation herbal antibiotics formulations. Based on the concentrations used, the phenolic compounds such as thymol and carvacol are categorized into either bactericidal agents or bacteriostatic agents. (Kamal Jeet *et al.*, 2012).

**Pharmacological Effects**

Ajwain has aromatic odour and species *Trachyspermum ammi* commonly known as Ajwain belonging to Apiaceae is a plant growing in India, Pakistan, South East and Near East of Iran. It is distributed throughout India, and it is mostly cultivated in Gujarat and Rajasthan, where the seeds are used as a spice. These seeds are used in Asian cooking, especially in India and for baking biscuits, breads and in bean dishes. Ajwain leaves are widely used to cure skin infections.

**Respiratory Effects**

One of the therapeutic effects of Ajwain is its effect on respiratory system. This plant is used as antiasthma and antidyspnea in traditional medicine which are found to have, antitussive effect in guinea pigs, and its bronchodilator effect on airways of asthmatic patients.

**Gastrointestinal Effects**

Ajwain and its traditional seeds are used in many gastrointestinal diseases such as intestinal disorders, abdominal pain (colic), or diarrhoea, is reported. This fruit has its profound effect on reducing the gastric ulcer index. It was also suggested that antiulcer effect of this plant is possibly due to its antioxidant effect.

**Antiparasitic Effects**

Infections due to filarial nematodes cause lymphatic filariasis and the application of synthetic drugs are not effective in destroying the parasites. Therefore, antifilarial effects of medicinal plant, namely, fruit extract of Ajwain, were shown *in vitro* and *in vivo*. Ajwain, thymol, and carvacrol have macrofilaricidal properties against adult bovine filarial worm *S. digitata in vitro*. In addition, the plant increased mortality and infertility of female worm of human filarial worm *Brugia malayi in vivo*.

**The Antimicrobial Effects**

Essential oil from Iranian Ajwain including 72.3% thymol inhibited gram-positive and gram-negative bacteria and viruses in which inhibition rate is associated with thymol content. The growth of gram-positive bacteria is inhibited through high dosage of thymol. The phenolic compounds act as antimicrobial agents by interfering the cell membrane, change pH and ion homeostatis. At all these studies the antimicrobial activity was examined by broth microdilution method.

**Antifungal Effects**

Antifungal activity of essential oil of Ajwain seeds is also documented against toxigenic *Aspergillus* species.



**Joonu****Antitoxic Effects**

Fungal species namely *Aspergillus flavus* and *Aspergillus parasiticus* produce Aflotoxins (a type of mycotoxins) which cause diseases in corn and rice plants. Ajwain seed extract is shown to have destructive effect on aflatoxin G1 (AFG1) and significantly reduced aflatoxin activities down to 65%.

**Neural Effects.**

Ajwain *aa* has been used in traditional medicine for relieving rheumatic, joint, headache, and neuralgic pain.(Boskabady *et al.*,2014).

**MATERIALS AND METHODS****Collection of Sample**

The medicinal plants *Trachyspermum ammi* (Ajwain) was collected from the local market of Tiruchirappalli district, Tamil Nadu, India. It was then used for the extraction of its bioactive compounds.

**Preparation of Plant Extract**

The dried seeds of Ajwain were crushed into fine powder with the help of a mechanical grinder .10g of the seeds powder was placed in a glass container and soaked in a 80% of methanol. The container with its content was sealed and kept for 7 days. The entire mixture then underwent a coarse filtration by a piece of clean, white cotton material. The extract then was filtered through Whatman filter paper. The extract was dried at room temperature and both the aqueous solution and solidified extract was stored under refrigeration for further studies. The same method was used for the preparation of Ethyl acetate extract.

**Analysis Of Phytochemical Compounds ( Wadood *et al*:2013)**

Screenings of medicinal plants for various phytochemical constituents were carried out using the following tests:

**Test for Phlobatannins**

Plant powder sample was mixed with distilled water in a test tube, then was shaken well, and filtered to take plant extract. Then, 1% aqueous hydrochloric acid was added and it was boiled with the help of Hot plate stirrer. Formation of red colour precipitate confirmed a positive result.

**Tests for reducing sugar:**

An amount of 0.50 g of plant sample was added in 5 ml of distilled water. Then 1 ml of ethanol mixed in plant extract. After that, 1 ml of Fehling solution A and 1 ml of Fehling solution B was added in a test tube, heated it to boiling and then poured it in the aqueous ethanol extract. When color reaction was observed, it shows a positive result.

**Test for terpenoids**

An amount of 0.8 g of plant sample was taken in a test tube, 10 ml of methanol was added, it was shaken well and filtered to take 5 ml extract of plant sample. Then 2 ml of chloroform were mixed in extract of plant sample and 3 ml of sulphuric acid were added in sample extract. Formation of reddish brown color indicates the presence of terpenoids in the selected plants.







Joonu

**Test for flavanoids**

0.5 g of plant extract was added in a test tube and 10 ml of distilled water, 5 ml of dilute ammonia solution were added to a portion of the aqueous filtrate of plant extract followed by addition of 1 ml concentrated H<sub>2</sub>SO<sub>4</sub>. Indication of yellow color shows the presence of flavonoid in each extract.

**Test for alkaloids**

0.2 g of the plant samples was added in the test tube and 3 ml of hexane were mixed in it, it was shaken well and filtered. Then took 5 ml of 2% HCl and poured in a test tube having the mixture of plant extract and hexane. The test tube was heated, filtered it and poured few drops of picric acid in a mixture. Formation of yellow color precipitate indicates the presence of alkaloids.

**Test for tannins: (watal et al,2014)**

2ml of extract sample was taken in a test tube, then 2ml of H<sub>2</sub>O was added in the test tube and 2-3 drops of FeCl<sub>3</sub>(5%) was added in the mixture. Green precipitate shows a positive result.

**Test for saponins (foam test)**

5ml extract was taken and it was mixed with 5ml of water and it was heated. Froth formation shows a positive result.

**Test for steroids (salkowski test)**

2ml of plant extract was taken in a test tube and 2ml of CHCl<sub>3</sub> was added and then 2ml of H<sub>2</sub>SO<sub>4</sub>(conc.) was added to the test tube .Reddish brown ring at the junction indicates positive result.

**Test for glycosides**

2ml of extract was taken and 2ml of CHCl<sub>3</sub> was added and 2ml of CH<sub>3</sub>COOH was added to the test tube.Violet to blue color formation indicates a positive result.

**Test for coumarins**

6.10 2ml of extract was taken and 3ml of NaOH(10%) was added .Yellow coloration indicates a positive result.

**Test for proteins (xanthoproteic test)**

1ml of extract was taken in a test tube and mixed with a 1ml of H<sub>2</sub>SO<sub>4</sub> (conc.).White precipitate will shows a positive result.

**Test for leucoanthocyanins test**

5ml of extract was taken in a test tube, and 5ml of Isoamyl alcohol was added. Organic layer into red will shows positive layer.

**Isolation of bacteria from soil: (cappuchino & Sherman, 2014)**

The soil sample was collected from the campus of Bishop Heber College, Tiruchirappalli District, Tamil Nadu, India .

**BIOCHEMICAL ANALYSIS: (Cappuchino & Sherma)**

**Characterisation of colonies**

The growth of microbes in different media leads to changes in the macroscopic appearance of their growth. These differences are called cultural characteristic and are used as the basis for separating microorganism into taxonomic groups.



**Joonu****Biochemical Analysis: (J. Joonu\* and Horne Iona Averal 2012)**

The colonies were identified by various biochemical tests such as IMViC, Catalase, oxidase, Triple sugar iron test etc. They are subjected to grow on different media and the colonies were analyzed. The differential media like EMB agar, MacConkey Agar, Urease agar, Pseudomonas agar, Blood agar etc. They were also identified by staining techniques.

**ANTIBACTERIAL ASSAY****Plate Method**

The three different strains of bacteria (Streptococcus, Enterobacter, and Bacillus) were subjected on agar media in separate petriplates. Each species of bacteria had three petriplates which were treated with different concentrations of Ajwain aqueous extract 5ml, 10ml and 15ml respectively. The antibacterial assay was performed using the two extracts of Methanol and Ethyl acetate separately. It was kept in the incubator for 48 hours and the Minimum Inhibition Concentration (MIC) was measured. The zone of inhibition was compared with the control using Gentamycin.

**HPLC Test**

High performance liquid chromatography (HPLC) is a versatile, robust, and widely used technique for the isolation of natural products (Maskouki A. M., 2004). Currently, this technique is gaining popularity among various analytical techniques as the main choice for fingerprinting study for the quality control of herbal plants (Fan *et al.*, 2006). The biologically active entity is often present only as a minor component in the extract and the resolving power of HPLC is ideally suited to the rapid processing of such multicomponent samples on both an analytical and preparative scale. Chemical separations can be accomplished using HPLC by utilizing the fact that certain compounds have different migration rates given a particular column and mobile phase. The extent or degree of separation is mostly determined by the choice of stationary phase and mobile phase. Generally the identification and separation of phytochemicals can be accomplished using an isocratic system (using a single unchanging mobile phase system). Gradient elution in which the proportion of organic solvent to water is altered with time may be desirable if more than one sample component is being studied and differ from each other significantly in retention under the conditions employed.

Purification of the compound of interest using HPLC is the process of separating or extracting the target compound from other (possibly structurally related) compounds or contaminants. Identification of compounds by HPLC is a crucial part of any HPLC assay. In order to identify any compound by HPLC, a detector must first be selected. The identifying peak should have a reasonable retention time and should be well separated from extraneous peaks at the detection levels which the assay will be performed. UV detectors are popular among all the detectors because they offer high sensitivity (Lia *et al.*, 2004) and also because a majority of naturally occurring compounds encountered have some UV absorbance at low wavelengths (190–210 nm) (Maskouki A. M., 2004).

The source material, e.g., dried powdered plant, will initially need to be treated in such a way as to ensure that the compound of interest is efficiently liberated into solution. In the case of dried plant material, an organic solvent (e.g., methanol, chloroform) may be used as the initial extractant and following a period of maceration, solid material is then removed by decanting off the extract by filtration. The filtrate is then concentrated and injected into HPLC for separation. The usage of guard columns is necessary in the analysis of crude extract.

**Cytotoxic screening: (usha met al., 2012)**

The Earthworm samples were collected from the campus of Bishop Heber College. Each earthworm was rinsed with distilled and deionized water; a buffer solution was added and was cut and crushed using a laboratory mortar. The resulting crushed tissues were centrifuged 4000r/min for 5min and the supernatant was removed and stored in a refrigerator. Serum was tested for Bilirubin (Total), Bilirubin (Direct), T. Protein, Albumin, AST/SGOT, ALT/SGPT, ALP and GGT.





### Joonu

The same species of earthworm was collected and kept in a container, which was treated with the powder of *Trachyspermum ammi* (Ajwain). After 2 days, no mortality was observed. And the treated earthworm were undergo the same procedure for the following test; Bilirubin (Total), Bilirubin (Direct), T. Protein, Albumin, AST/SGOT, ALT/SGPT, ALP and GGT.

$$\text{Percentage of mortality} = \frac{\text{No. of dead earthworm}}{\text{No. of earthworm introduced}} \times 100$$

### SPSS

SPSS version 16 was used to calculate the correlation and ONE WAY ANOVA for the OD values of antibacterial assays done with the nutrient broth using the two extract of Ajwain in different concentrations(5ml,10ml,15ml).

## RESULTS

Photochemical analysis (Table .1 ), Biochemical analysis (Table 2.), Antibacterial assay (Table 3.), Ethyl Acetate Extract (Table 4. - Table 6.), Methanol Extract (Table 7. - Table 10), ONEWAY ANOVA showing the growth of bacteria in the presence of Ethyl acetate extract of *Trachyspermum ammi*, POST HOC TEST (Table 12) CORRELATION showing the growth of bacteria in the presence of Ethyl acetate extract of *Trachyspermum ammi* (Table 13), Homogeneous Subsets (Table 16), CORRELATIONS showing the growth of bacteria in the presence of Methanol extract of *Trachyspermum ammi* (Table 17. -18) HPLC Results (Table 19)

## DISCUSSION

In this present study, the bacteria were isolated from the soil which was collected from the Bishop Heber College campus, Trichy, Tamil Nadu, India. Using the Serial Dilution Method, the soil sample was used for isolation of the bacteria. Biochemical analysis was done for all the dilution containing the bacteria. It was observed that the bacteria present in the soil sample were *Streptococcus spp.*, *Enterobacter ssp.* and *Bacillus spp.*(Fig4;Table 2). Gram staining was performed for the three strains of bacteria. Among the three bacteria, two shows Gram-positive (+) i.e. *Streptococcus spp.* and *Bacillus spp.* Where as *Enterobacter spp.* shows gram-negative (-).

The most frequently isolated genus has been *Bacillus spp.*, but we have also seen *Streptococcus spp.*, *Staphylococcus spp.*, and *Escherichia spp.* Other less frequent bacteria are *Arthrobacter* and *Actinomyces*. (Patricia M. Steubing, 1993). *Enterobacter spp.* infections can include bacteremia, lower respiratory tract infections, skin and soft-tissue infections, urinary tract infections (UTIs), endocarditis, intra-abdominal infections, septic arthritis, osteomyelitis, CNS infections, and ophthalmic infections.

Cytotoxic screening was done on earthworm using the extract of Ajwain (*Trachyspermum ammi*). The collected samples of earthworm were cut and crushed using a laboratory mortar(Fig.6.1,6.2). The resulting crushed tissues were centrifuged 4000r/min for 5min and the supernatant was removed and stored in a refrigerator (Ukpabi C. F *et al.*, 2013). And the serum sample was used for Protein liver Function test. In this screening, liver function test; Bilirubin (Total), Bilirubin (Direct), T. Protein, Albumin, AST/SGOT, ALT/SGPT, ALP and GGT were done on the serum sample of earthworm. The test was performed before treated with Ajwain extract, the test showed a result (<0.2, <0.1,<1.0,<0.5, 430,20,454,18) and after treated with the Ajwain extract, the result of this liver function test was decreased (<0.10 ,0.18,<0.50, <0.20 ,23,6,351,17) compared with the result of before treated with Ajwain.(Table 4). This shows that there is a decrease in the liver enzymes by treating it with the Ajwain powder. Increase in these liver





### Joonu

enzymes causes liver damage and liver cirrhosis. By treating with *Trachyspermum ammi* (Ajwain) powder, the liver enzymes were decreased which shows normal liver function and effective result.

HPLC test were also done for both the methanol and ethyl acetate seed extract of *Trachyspermum ammi* (Ajwain) in which the presence of compounds were confirmed.(Graph 1 Fig 2 & Fig. 3). It has been mentioned that antioxidant activity of plants might be due to their phenolic compounds (Cook and Samman, 8). Flavonoids are a group of polyphenolic compounds with known properties which include free radical scavenging, inhibition of hydrolytic and oxidative enzymes and anti-inflammatory action (Frankel, 10). Some evidence suggests that the biological actions of these compounds are related to their antioxidant activity (Gryglewski et al., 13). By using SPSS (version 16), the antibacterial assays of the nutrient broth of both the extracts (Methanol and ethyl acetate) were calculated. Correlation and ANOVA were done on the OD values obtained from the antibacterial assay. The result shows that the correlation is significant and hence rejects the null hypothesis.(Table.13,14,17 &18).

## REFERENCES

1. Gryglewski RJ, Korbut R, Robak J (1987). On the mechanism of antithrombotic action of flavonoids. *Biochemical Pharmacol* 36: 317- 321.
2. Wadood A, Ghufuran M, Jamal SB, Naeem M, Khan A, et al. (2013) Phytochemical Analysis of Medicinal Plants Occurring in Local Area of Mardan.
3. *Biochem Anal Biochem* 2: 144
4. Kamal Jeet, Nisha Devi, Thakur Narender, Tomar Sunil, Shalta Lali, Thakur Raneev , 2012,3(5). Vinayaka College of Pharmacy, Kullu (H.P), India. College of Ayurvedic Pharmaceutical Sciences, Jogindernagar (H.P), India.
5. Boskabady M.H, Rakhshandah H, and Moetamedshariati H, "Bronchodilatory and anticholinergic effects of *Carum copticum* on isolated guinea pig tracheal chains," *Medical Journal of the Islamic Republic of Iran*, 1998,Vol.11; pp. 329–334
6. Ishikawa T, Segal Y, Kitajima J. Water-soluble constituents of Ajowan. *Chem Pharmaceut Bull.* 2001; 49(7):840–44.
7. Maskouki A. M. , Mortazavi. A. Inhibitory Effects of Thyme and Ajowan Oils on Growth of *Aspergillus parasiticus* on Pear During Cold Storage. *Isfahan Univ Technol.* 2004;8(2):207–15.
8. Usha M, Ragini S, Naqvi S. Antibacterial activity of acetone and ethanol extracts of Cinnamon (*Cinnamomum zeylanicum*) and Ajwain (*Trachyspermum ammi*) on four food spoilage bacteria. *Int Res J Biol Sci.* 2012;1(4):7–11.
9. Patricia M. Steubing. 1993 Isolation of an unknown bacterium from soil. Pages 81-114, in *Tested studies for laboratory teaching*, Volume 14 (C. A. Goldman, Editor). Proceedings of the 14th Workshop/Conference of the Association for Biology Laboratory Education (ABLE).
10. Ukpabi C. F *et al.*, 2013
11. Joonu J., Averal H.I., (2012). Isolation and characterization of bacteria from a heavy metal polluted environment. *Science research reporter.* 2(3): 7-18.
12. Frankel, E. 1995. Nutritional benefits of flavonoids. In: *International conference on food factors: Chemistry and Cancer Prevention*. Hamamatsu, Japan. Abstracts, C6-2 10.
13. Furuta, S., Nishiba, Y. & Suda, I. (1997). Fluorometric assay for screening antioxidative activity of vegetables. *Journal of Food Science*, 62, 526-528. 11.
14. Gazzani, G., Papetti, A., Massolini, G. and Daglia, M. 1998. Antioxidative and pro-oxidant activity of water soluble components of some common diet vegetables and the effect of thermal treatment. *J. of Food Chem.* 6: 4118- 4122. ISSN: 2249 – 2321
15. Lia, H.B., Jiang, Y. and Chen, F. (2004). Separation methods used for *Scutellaria baicalensis* active components . *J. Chromatogr. B.* 812: 277–290.
16. Fan, X.H., Cheng, Y.Y., Ye, Z.L., Lin, R.C. and Qian, Z.Z. (2006). Multiple chromatographic fingerprinting and its application to the quality control of herbal medicines. *Anal. Chim. Acta* 555: 217-224





### Joonu

**Table .1 Phytochemical analysis**

Sl.no.	Phytochemical compounds	Observation	RESULT	
			Methanol extract	Ethyl acetate extract
1	Phlobattanins	Red color	Negative (-)	Negative(-)
2	Reducing sugar	Color reaction	Negative (-)	Negative (-)
3	Terpenoids	Reddish brown color	Negative (-)	Negative (-)
4	Flavonoids	Yellow color	Negative (-)	Negative (-)
5	Alkaloids	Yellow color	Negative (-)	Negative (-)
6	Tannins	Green precipitate	Positive (+)	Positive (+)
7	Sapponins	Froth appears	Negative (-)	Negative (-)
8	Steroids	Reddish brown ring	Positive (+)	Positive (+)
9	Glycosides	Violet to blue to green coloration	Negative (-)	Negative (-)
10	Coumarins	Yellow coloration	Positive (+)	Positive (+)
11	Proteins	White precipitate	Negative (-)	Negative (-)
12	Leucoanthocyanins	Organic layer into red	Negative (-)	Negative (-)

**Table 2. Biochemical analysis**

SL.NO.	BIOCHEMICAL TESTS	OBSERVATION	RESULTS	ORGANISM
1	Indole Test (Tryptone broth)	Red layer at the top	Negative(-)	-
2	Methyl Red Test (MRVP broth)	Red layer at the top	Negative (-)	-
3	Macconkey Agar	Bright pink red colonies	Positive(+)	<i>Enterobacter spp.</i>
4	Voges proskauer Test	Pink/Red	Negative(-)	-
5	Mannitol Fermentation	Red to yellow	Negative(-)	-
6	Catalase Test	Gas bubbles	Positive(+)	<i>Bacillus spp.</i>
7	Citrate Agar Test	Yellow to cerise	Negative(-)	-
8	Starch	A clear zone	Negative(-)	-
9	Blood Agar	-	Positive(+)	<i>Streptococcus spp.</i>
10	Eosin Methylene Blue	Pink colonies	Positive(+)	<i>Enterobacterterter spp.</i>

**Antibacterial assay**
**Table 3. Plate Method (Ethyl acetate and Methanol extract)**
**Control: Gentamycin against *Streptococcus spp.*, *Enterobacter spp.* and *Bacillus spp.***

SL.NO.	ORGANISMS	Radius of Zone of Inhibition
1	<i>Streptococcus spp.</i>	20mm
2	<i>Enterobacter spp.</i>	15mm
3	<i>Bacillus spp.</i>	15mm





## Joonu

## Ethyl Acetate Extract

Table 4. Antibacterial activity of *Trachyspermum ammi* (Ajwain) ethyl acetate extract against *streptococcus spp.*

Sl.no.	Concentration	Control	Radius of zone of inhibition	Sensitivity
1	5	20	6mm	Sensitive
2	10	20	15mm	Sensitive
3	15	20	15mm	Sensitive

Table 5. Antibacterial activity of *Trachyspermum ammi* (Ajwain) ethyl acetate extract against *Enterobacter spp.*

Sl.no.	Concentration	Control	Radius of zone of inhibition	Sensitivity
1	5	15	10mm	Sensitive
2	10	15	15mm	Sensitive
3	15	15	15mm	Sensitive

Table 6. Antibacterial activity of *Trachyspermum ammi* (Ajwain) ethyl acetate extract against *Bacillus spp.*

Sl.no.	Concentration	Control	Radius of zone of inhibition	Sensitivity
1	5	15	5mm	Resistant
2	10	15	10mm	Sensitive
3	15	15	10mm	sensitive

## METHANOL EXTRACT

Table 7. Antibacterial activity of *Trachyspermum ammi* (Ajwain) methanol extract against *Streptococcus spp.*

Sl.no.	Concentration	Control	Radius of zone of inhibition	Sensitivity
1	5	20mm	5mm	Resistant
2	10	20mm	8mm	Sensitive
3	15	20mm	10mm	Sensitive

Table 8. Antibacterial activity of *Trachyspermum ammi* (Ajwain) methanol extract against *Enterobacter spp.*

Sl.no.	Concentration	Control	Radius of zone of inhibition	Sensitivity
1	5	15mm	5mm	Resistant
2	10	15mm	15mm	Sensitive
3	15	15mm	15mm	Sensitive

Table 9. Antibacterial activity of *Trachyspermum ammi* (Ajwain) methanol extract against *Bacillus spp.*

Sl.no.	Concentration	Control	Radius of zone of inhibition	Sensitivity
1	5	15	3mm	Resistant
2	10	15	8mm	Sensitive
3	15	15	10mm	Sensitive

Table 10. Cytotoxic test on earthworm

Sl.no.	Test	Result (before treated)	Result(treated with ajwain extract)	Normal range	Units
1.	Bilirubin (Total)	<0.2	<0.10	0.3-1.9	mg/dl
2.	Bilirubin (Direct)	<0.1	0.18	0-0.3	mg/dl
3.	T.Protein	<1.0	<0.50	6-8.3	gm/dl
4.	Albumin	<0.5	<0.20	3.5-5.3	gm/dl





**Joonu**

5.	AST/SGOT	430	23	8-48	U/I
6.	ALT/SGPT	20	6	7-55	U/I
7.	ALP	454	351	45-115	U/I
8.	GGT	18	17	9-48	U/I

**Table 11. ONEWAY ANOVA showing the growth of bacteria in the presence of Ethyl acetate extract of *Trachyspermum ammi*:**

<b>ANOVA</b>						
		Sum of Squares	df	Mean Square	F	Sig.
Concentrations	Between Groups	.000	2	.000	.000	1.000
	Within Groups	18.000	24	.750		
	Total	18.000	26			
Hours	Between Groups	.000	2	.000	.000	1.000
	Within Groups	18.000	24	.750		
	Total	18.000	26			
Growth	Between Groups	.041	2	.021	.510	.607
	Within Groups	.972	24	.041		
	Total	1.014	26			

**POST HOC TEST**

**Table 12. Homogeneous subsets**

<b>DUNCAN CONCENTRATIONS</b>		
Organisms	N	Subset for alpha =0.05 1
<i>Bacillus spp.</i>	9	2.0000
<i>Enterobacter spp.</i>	9	2.0000
<i>Streptococcus spp.</i>	9	2.0000
Sig.		1.000

<b>DUNCAN HOURS</b>		
Organisms	N	Subset for alpha =0.05 1
<i>Bacillus</i>	9	2.0000
<i>Enterobacter</i>	9	2.0000
<i>Streptococcus</i>	9	2.0000
Sig.		1.000

<b>DUNCAN GROWTH</b>		
Organisms	N	Subset for alpha =0.05 1
<i>Bacillus spp.</i>	9	.2767
<i>Enterobacter spp.</i>	9	.3378
<i>Streptococcus spp.</i>	9	.3711
Sig.		.357





**Joonu**

**Table 13. CORRELATION showing the growth of bacteria in the presence of Ethyl acetate extract of *Trachyspermum ammi*.**

	MEAN	Std. Deviation	N
ORGANISMS	2.0000	.83205	27
CONCENTRATIONS	2.0000	.83205	27
HOURS	2.0000	.83205	27
GROWTH	.3285	.19746	27

**Table 14. Correlations**

		Organisms	Concentrations	Hours	Growth
Organisms	Pearson correlation	1	0.000	0.000	.129
	Sig.(2-tailed)		1.000	1.000	.522
	N	27	27	27	27
Concentrations	Pearson correlation	.000	1	.000	-.250
	Sig.(2-tailed)	1.000		1.000	.208
	N	27	27	27	27
Hours	Pearson correlation	.000	.000	1	-.707
	Sig.(2-tailed)	1.000	1.000		.000
	N	27	27	27	27
Growth	Pearson correlation	.129	-.250	-.707	1
	Sig.(2-tailed)	.522	.208	.000	
	N	27	27	27	27

Correlations is significant at the 0.01 level (2-tailed).

**Table 15. ONEWAY ANOVA showing the growth of bacteria in the presence of Methanol extract of *Trachyspermum ammi*:**

		Sum of Squares	df	Mean square	F	Sig.
Concentrations	Between groups	.000	2	.000	.000	1.000
	Within groups	18.000	24	.750		
	Total	18.000	26			
Hours	Between groups	.000	2	.000	.000	1.000
	Within groups	18.000	24	.750		
	Total	18.000	26			
Growth	Between groups	.006	2	.003	.083	.921
	Within groups	.817	24	.034		
	Total	.823	26			

+  
 \-

**POST HOC TESTS**

**Table 16. Homogeneous Subsets**

Duncan		Concentrations	
Organisms	N	Subset for alpha=0.05	
		1	
<i>Bacillus spp.</i>	9	2.0000	
<i>Enterobacter spp.</i>	9	2.0000	







**Joonu**

<i>Streptococcus spp.</i>	9	2.0000
Sig.		1.000

Mean for groups in homogeneous subsets are displayed.

**Duncan Hours**

Organisms	N	Subset for alpha=0.05
		1
<i>Bacillus spp.</i>	9	2.0000
<i>Enterobacter spp.</i>	9	2.0000
<i>Streptococcus spp.</i>	9	2.0000
Sig.		1.000

Mean for groups in homogeneous subsets are displayed.

**Duncan Growth**

Organisms	N	Subset for alpha=0.05
		1
<i>Bacillus spp.</i>	9	.3100
<i>Enterobacter spp.</i>	9	.3200
<i>Streptococcus spp.</i>	9	.3444
Sig.		.713

Mean for groups in homogeneous subsets are displayed.

**CORRELATIONS showing the growth of bacteria in the presence of Methanol extract of *Trachyspermum ammi*:**

**Table 17. Descriptive Statistics**

	Mean	Std. Deviation	N
Organisms	2.000	.83205	27
Concentrations	2.000	.83205	27
Hours	2.000	.83205	27
Growth	.3248	.17790	27

**Table 18. Correlations**

		Organisms	Concentrations	Hours	Growth
Organisms	Pearson Correlation	1	0.000	0.000	-.023
	Sig. (2-tailed)		1.000	1.000	.908
	N	27	27	27	27
Concentrations	Pearson Correlation	.000	1	0.000	-.400'
	Sig. (2-tailed)	1.000		1.000	.039
	N	27	27	27	27
Hours	Pearson Correlation	.000	0.000	1	-.803''
	Sig. (2-tailed)	1.000	1.000		.000
	N	27	27	27	27
Growth	Pearson Correlation	-.023	-.400'	-.803''	1
	Sig. (2-tailed)	.908	-.039	.000	
	N	27	27	27	27

Correlations is significant at the 0.05 level (2-tailed).

Correlations is significant at the 0.01 level (2-tailed):





**Joonu**

**Table 19. HPLC results**

S.No	Compound	Retention time
1.	Quercetin	3.332
2.	flavonoids, diterpenoids, Quinone	4.206

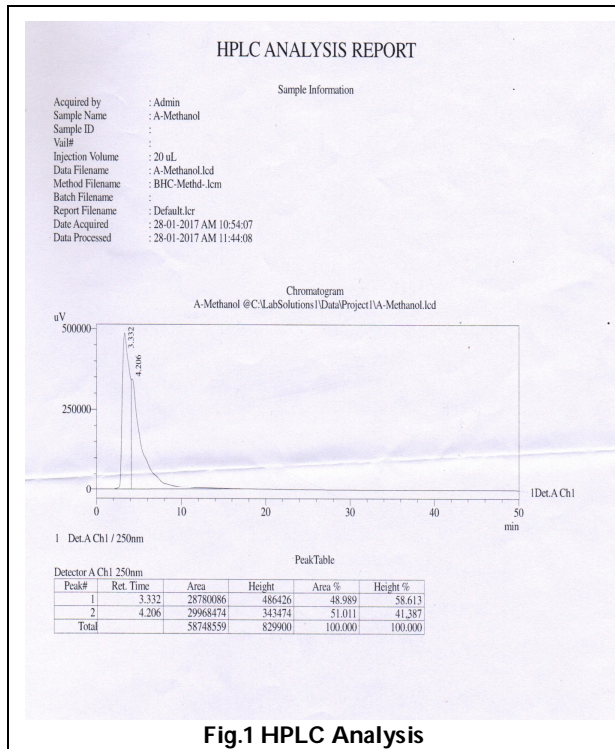

**Fig.1 HPLC Analysis**

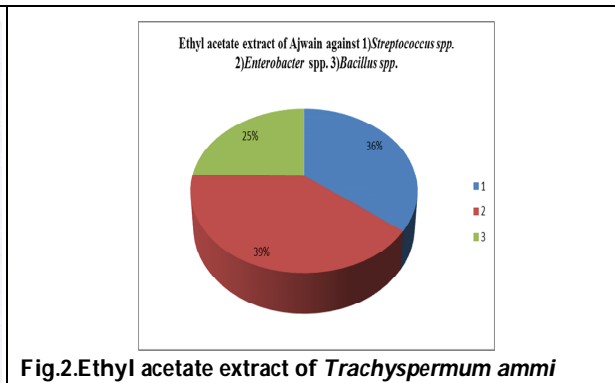

**Fig.2. Ethyl acetate extract of *Trachyspermum ammi***

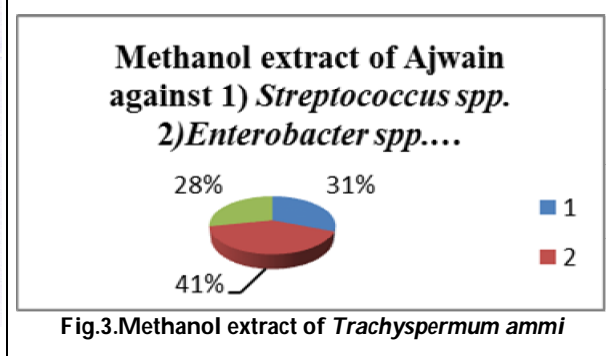

**Fig.3. Methanol extract of *Trachyspermum ammi***





## A Review on Nutritional Anemia

Preetha Bhadra<sup>1\*</sup> and Atanu Deb<sup>2</sup>

<sup>1</sup>Assistant Professor, Department of Biotechnology, M.S. Swaminathan School of Agriculture, Centurion University of Technology and Management, Parlakhemundi, Odisha, India

<sup>2</sup>Assistant Professor, Department of Agricultural Extension, M.S. Swaminathan School of Agriculture, Centurion University of Technology and Management, Parlakhemundi, Odisha, India

Received: 14 Jan 2020

Revised: 16 Feb 2020

Accepted: 20 Mar 2020

### \*Address for Correspondence

#### Preetha Bhadra

Assistant Professor, Department of Biotechnology,  
M.S. Swaminathan School of Agriculture,  
Centurion University of Technology and Management,  
Parlakhemundi, Odisha, India.  
Email: preetha.bhadra@cutm.ac.in



This is an Open Access Journal / article distributed under the terms of the **Creative Commons Attribution License** (CC BY-NC-ND 3.0) which permits unrestricted use, distribution, and reproduction in any medium, provided the original work is properly cited. All rights reserved.

### ABSTRACT

A range of health problems can arise from nutritional deficiency. Anemia is a condition that happens when your body doesn't have enough healthy red blood cells or hemoglobin. The main component of blood is hemoglobin which carries oxygen to the cells. Its reduction causes decrease in the availability of oxygen in the body thereby causing anemia. The main symptoms generally includes shortness of breath, dizziness, headache, chest pain, pale skin, increase in heartbeat. The main causes surrounding the occurrence of anemia is due to heavy blood loss, ongoing chronic diseases, mutation and poor nutrition. This paper mainly focus on anemia caused due to nutritional deficiency. It is a common condition that results from lack of certain vitamins and minerals leading to malnutrition. Nutritional deficiency anemia mainly results from lack of iron, vitamin B12 & a low vitamin C intake. Detection can be done by observing complete blood count of patient, which is done as a part of routine general check up. Other than this, physical examination & medical history also play a crucial role in diagnosis of anemia. Treatment of nutritional deficiency anemia is through a varied diet including mineral rich, fortified foods, vitamins & mineral supplements.

**Key Words:** Anemia, Hemoglobin, Nutrition, RBC count, Vitamin.

### INTRODUCTION

Nutritional anemia is the most prevalent nutritional disorder in the world. This a global public health problem which affects both developed and developing countries with major consequences for human health and their social and

18674



**Preetha Bhadra and Atanu Deb**

economic development (WHO 2005). According to WHO (2008) reports 24.8% of the global population (over 1.62 billion ) are anemic due to imbalance in their food intake. 10 million cases has been reported in India. In a healthy person, a state of nutritional balance exists: the amount of food eaten is equal to the amount of nutrients for the proper functioning of the body (S Herceberg and C Rouaud,1981). This imbalance is due to decrease in nutrition, increase in losses, increased needs, decreased absorption, and decreased utilization. It is result of deficiency of one or more essential nutrients in the body, specially iron.

When these are exhausted, all the bodily functions in which this nutrient plays a part are affected. Anemia is a caused by lack of red blood cells or hemoglobin. The body unable to produce enough healthy red blood cells. Hemoglobin is the protein molecule in RBCs that transport oxygen to the body tissues. Since hemoglobin carries oxygen from lungs to capillaries, anemia leads to hypoxia. Human beings need oxygen for their survival, anemia can have wide range of health problems. So, deficiency of RBC reduces the amount of oxygen available to the body. Anemia remain undetermined in people & symptoms can be minor. The signs and symptoms can be related to the underlying cause or the anemia itself. Most commonly, people with anemia report feelings of weakness, or fatigue, and shortness of breath. In very severe anemia, the body may compensate for the lack of oxygen-carrying capability of the blood by increasing cardiac output (S.R. Kane et al, 2016). Anemia is more prone in women of reproductive age (14 - 45 yrs old) and children. Women require special nutrition because of their period of menstruation, pregnancy, lactation that they experience in their life. There is heavy blood loss during menstruation and pregnancy (Saranaz Jangjoo and Leila Hosseini,2016).

The elements which contribute to the formation and development of red corpuscles and to the synthesis of hemoglobin are iron; other minerals, i.e., copper, zinc, magnesium, cobalt, molybdenum, vitamins, especially folic acid and vitamin B12, and amino acids. Many factors contribute to the development of nutritional anemia including lack of food, certain customs and habits. An increase in available foodstuffs, better utilization of resources, and better living conditions lead to more balanced nutrition.

**Anemia and RBC**

On the basis of size of RBCs anemia can be of 3 types i) Microcytic anemia – when the red blood cells are too small than the normal blood cell volume. It is mostly caused by iron deficiency. ii) Normocytic anemia – red blood cells are of normal size. But they are present in very little amount. iii) Macrocytic anemia – when the red blood cells are larger than the normal blood cell volume.

Major Causes of anemia can be described as i) Blood loss (menstruation bleeding, ulcer, hemorrhoids). ii) Decreased or faulty RBC production. iii) Destruction of RBC, Improper growth & Maturation of RBC. iv) Deficiency of iron in the body v) Vitamin deficiency (B12 and Folate essential for growth of RBC), Poor diet, unhealthy food, Crescent shape of blood cell. General Symptoms of anemia are, i) Paleness of skin, Shortness of breath, ii) Dizziness and headache, easy fatigue and loss of energy. iii) Clumsiness and stiffness of arms and legs. Pins and needle sensation in the hand and feet. iv) chest pain, Faster or irregular heartbeat.

**Different types of nutritional anemia -  
Iron Deficiency anemia**

It is essential for various activities of human body especially in the hemoglobin synthesis. Iron deficiency anemia is a condition in which the body has too little iron or insufficient iron. Failure to meet the demand of iron, body can't produce enough of a substance in red blood cells that enables them to carry oxygen (hemoglobin). So, iron deficiency anemia may leave our body tired and short of breath. This form of anemia more common in adolescent and women before menopause. blood loss from heavy period, internal bleeding from gastrointestinal tract or donating too much





### Preetha Bhadra and Atanu Deb

blood cells can all contribute to this disease (Soundarya, N. et al., 2016). Deficiency anemia can occur during pregnancy or childhood growth spurts, heavy menstrual periods, poor absorption of iron, bleeding from the gut (intestines), dietary factors (iron poor or restricted diet), medication (aspirin, ibuprofen, naproxen and diclofenac), lack of certain vitamins (folic acid, vitamin B12), bleeding from the kidney, hookworm infection, red blood cell problems, bone marrow problems (Harper et al., 2015).

Symptoms are tiredness, lethargy, feeling faint, headache, irregular heart beat, pale skin, cold hands and feet. You can usually correct iron deficiency anemia with iron supplementation. Sometimes additional tests or treatments for iron deficiency anemia are necessary, especially if your doctor suspects that you're bleeding internally. Women, infants, children, frequent blood donors have an increased risk of having anemia. Prevention can be done by i) consumption of iron-rich food such as red meat, pork, poultry, sea food, ii) beans, dark green leafy vegetables, dried fruits, peas. iii) Food containing vitamin C enhances iron absorption; these are broccoli, tomatoes, orange, lemon. To prevent iron deficiency anemia in infants, feed baby breast milk or iron-fortified formula for the first year. Cow's milk isn't a good source of iron for babies and isn't recommended for infants under 1 year. After age 6 months, start feeding your baby iron-fortified cereals or pureed meats at least twice a day to boost iron intake.

#### Vitamin B12 deficiency anemia

Vitamin B<sub>12</sub> deficiency anemia is a condition in which your body lacks enough healthy red blood cells, due to a lack (deficiency) of vitamin B<sub>12</sub>. This vitamin is needed to make red blood cells, which carry oxygen to all parts of your body. Without enough red blood cells, our tissues and organs don't get enough oxygen. Without enough oxygen, the body can not function properly. Low level of vitamin B<sub>12</sub> can lead to pernicious anemia. Causes of vitamin B<sub>12</sub> deficiency anemia - Lack of intrinsic factor - Intrinsic factor is a protein made in the stomach. It is needed to absorb vitamin B<sub>12</sub>. This type of B<sub>12</sub> deficiency anemia is called pernicious anemia. Surgery that removes or bypasses the end of the small intestine. This part of the small intestine is where vitamin B<sub>12</sub> is absorbed. Risk factors for vitamin B<sub>12</sub> deficiency anemia include: i) A family history of the disease, ii) Having part or all of your stomach or intestine removed, iii) Autoimmune diseases, including type 1 diabetes, iv) Cohn's disease, HIV, v) Some medicines, vi) Strict vegetarian diets.

Symptoms may include: i) Weakening of muscles, ii) tingling feeling in hands and feet, iii) Trouble in walking, iv) Nausea, v) Decreased appetite, vi) Weight loss of body, vii) Lack of energy or tiredness (fatigue), viii) Diarrhea, ix) Fast heart rate. Food sources of vitamin B<sub>12</sub> include breakfast cereals with added vitamin B<sub>12</sub>, meats such as beef, liver, poultry, and fish, eggs, dairy products (such as milk, yogurt, and cheese), foods fortified with vitamin B<sub>12</sub>, such as soy-based beverages and vegetarian burgers.

#### Folate deficiency anemia -

Folate-deficiency anemia is caused due to the lack of folic acid in the blood. Folic acid is a B<sub>9</sub> vitamin that helps your body make red blood cells. If you don't have enough red blood cells, you have anemia. Red blood cells carry oxygen to all parts of your body. When the body has anemia, cells did not get enough oxygen for the proper function of body parts. Low levels of folic acid can cause megaloblastic anemia. With this condition, red blood cells are larger than normal. There are fewer of these cells. They are also oval-shaped, not round. Sometimes these red blood cells don't live as long as normal red blood cells. Causes of folate-deficiency anemia, i) If the diet lacks food with vitamin B<sub>9</sub>, ii) If a person drinks too much alcohol, iii) diseases of the lower digestive tract, such as celiac disease. This type of anemia also occurs in people with cancer. iv) If a person taking medication, such as some used for seizures. v) In pregnant women because the developing baby needs more folic acid. Also, the mother absorbs it more slowly. A lack of folate during pregnancy is linked to major birth defects that affect the brain, spinal cord, and spine (neural tube defects). The body is unable to absorb folate. Symptoms may include: Paleness of skin, Decreased appetite, Being



**Preetha Bhadra and Atanu Deb**

grouchy (irritable), Lack of energy or getting tired easily, Diarrhea, Smooth and tender tongue. Treatment may include: Vitamin and mineral supplements, Changes in the diet, Medicine, Leafy vegetables, citrus fruits, beans, and whole grains are natural sources of folic acid. Complications of folate-deficiency anemia -Folate-deficiency anemia during pregnancy may cause a neural tube defect. This is when the brain or spinal cord doesn't develop normally. It can cause death before or soon after birth. Or it may cause paralysis of the legs.

**Other nutritional deficiencies which leads to anemia -**

Riboflavin ( vitamin B12) deficiency contribute to development of anemia. It effects on iron metabolism including decreasing iron mobilization from stores, decreasing iron absorption and increase in iron losses (Fishman SM et.al ,2000). Riboflavin supplements provided along with iron supplements have been shown to have a greater effect on haemoglobin concentration than iron supplements alone (Rohner F. et.al, 2007). Riboflavin deficiency has been reported in pregnant women, lactating women, infants, school children. Vitamin C deficiency contribute to hemolysis ,which leads to damage and destruction of erythrocytes. Vitamin C affects iron metabolism and enhance absorption of non – haem iron( Fishman SM et.al ,2000) . Populations at risk of vitamin C deficiency include pregnant women, infants fed exclusively with cow's milk, the elderly and smokers. Vitamin C supplementation increase hemoglobin concentration and serum ferritin level in children and non-pregnant women ( Fishman SM et.al ,2000). The mechanism linking vitamin D deficiency to decreased hemoglobin concentration is not entirely understood, but there is evidence indicating that low levels of vitamin D may lead to decreased local calcitriol production in the bone marrow, which may limit erythropoiesis (Atkinson MA et.al,2014).

**DIAGNOSIS**

Diagnosis of anemia can be done by – i) Complete blood count (CBC) test, ii) determines the number iii) volume, hemoglobin content of red blood cell, iv) Blood iron level and serum ferritin level test, v) Test for level of vitamin B12 & Folate vi) Reticulocyte count, bilirubin , urine test to determine the time of formation of red blood cells vii) Physical examination and evaluation of medical history of patient.

**METHODOLOGY**

These are some of the findings of the researchers related to nutritional anemia. Generally anemia affecting children, girls and women. A study conducted by Nkechi G. onyeneho et.al, 2019 revealed that childhood anemia is still one of the most prevalent nutritional disorder faced by mothers and children in India despite private and public organization to anemia rates reported in demographic studies. In the year 2005/06 National Family Health Survey (NFHS) in India revealed that at least 80% children of the age group 12-23 months are anemic and below 5 years 69.5% are anemic. In 2015 Demographic health survey it is revealed that only 11% point decrease from 69.5 to 58.5% childhood anemia in India, still it is endemic. childhood anemia in India results due to consumption of low micronutrients(specially iron) and compounded some socioeconomic condition. Combination of nutritional supplementation and food fortification programmes efforts to reduction in anemia. Study conducted by Nupura A. vibhute et.al, 2019 among 300 female medical students revealed that 86 students are anemic , about 54 has mild anemia and 32 has moderate anemia . no cases of severe anemia is noted.

This study high light that anemia can affect even medical female students who are a vulnerable group unexpectedly suffering from nutritional deficiencies. Anemia affect medical students because of their long working hours, busy and hectic schedules, erratic meal times. Study conducted by Altaf B et.al , 2018 among 112 medical students of age 19.3 , of total population 58 and 54 are male and female respectively . Study also reveals very often that 49.1 % were consuming junk food and 69.1% were anemic among junk food consumers and their hemoglobin level is lower than the students who are non consumers of junk food. Recent studies show that nutritional anemia prevalent in 65%



**Preetha Bhadra and Atanu Deb**

infants and toddlers, 60% 1-6 years of age , 88% adolescent girls,85% pregnant women. Anemia was marginally higher in lactating women as compared to pregnancy . National programmes to control and prevent anemia have not been successful . Control measures of anemia are fortification of food items like milk , cereals , sugar , salt with iron . Nutritional education to improve dietary intakes in family for receiving needed macro or micro nutrients as protein, iron and vitamins like folic acid ,B12, C , A etc. As an immediate measure medicinal iron is necessary to control anemia.

**DISCUSSION**

Anemia is the most common nutritional disorder worldwide, affects mostly young children and women of reproductive age (14-45years). Iron deficiency is the most common nutritional Nutritional deficiency anemia affects 52% Indian women as per WHO statistics. Anemia occurs due to the poor eating habits and consumption of junk food which lacks essential nutrient. Skipping meals on time, less intake fruits and vegetables, consumption of fizzy drinks leads to anemia. Foods like burger, pasta, bread, pizza contain phytates which decreases absorption of Iron. Trend of eating junk food is increasing among people as they have changed their lifestyle and food habits. Anemia may cause severe health issues and affects a person overall health and well being. Proper nutrient rich food should be included in diet. Red meat, tofu, fish, eggs, cereals, dark green vegetables are essential source of Iron. Pulses, beans, nuts are rich in vitamins. Citrus fruits are rich in vitamin C . These foods should be included in diet instead of junk food which are not good for health. Regular health check up can be done to diagnose disease. Improvement in the food habits can decrease the risk of having anemia. Poor eating habits, skipping meals, consuming junk food is a major cause of anemia among students.

Even students studying medicine also follow the same pattern in spite having better knowledge of health and better availability of health facilities. Intervention program on anemia should be done in college to spread awareness among students. Government should create programs for easy accessibility of iron to women. As due to poverty many can people cannot access nutrient rich food, fortification of food is essential. Awareness should be spread for the pre natal care of mother to bear healthy child. Mothers should take food enriched with nutrients which good for her health and child. Girls should avoid junk food and must eat healthy foods for proper absorption of iron. As the anemia is not more prevalent in men but they also should eat healthy food for proper functioning of body parts and to remain disease free. Anemia is not a disease it is a disease process if this can be controlled then many fatal disease could not ruin the body. So many clinical health problems can be prevented by maintain the blood hemoglobin level. Nutritional deficiency has a determinant effect on students and young children who are the future of a nation. Healthy body and mind have a good impact on a Nation socio- economic status. .

**CONCLUSION**

Nutritional anemia caused due to the deficient of essential nutrient in body. Anemia is mostly gender specific as it mostly affects women. Also it has determinant effect on younger children. It can be cured by eating healthy nutrient rich food. Improvement in the food habit can prevent the occurrence of anemia. There is a urgent need for government program for spreading awareness among people of rural and urban area and supplementation of iron fortified foods to women.

**REFERENCES**

1. Allen LH: Nutritional influences on linear growth : a general review . Eur J Clin Nutr 1994, 48 (Suppl I):S75-S89.DOI: 10.29309/TPMJ/18.4449.
2. Altaf B, Khan MB, Aftab RK , Jawed S , Salam RMT, Amir F. Nutritional deficiency anemia ;role of junk food in nutritional deficiency anemia among youngsters . Professional Med J 2018 ; 25 (7): 1018-1023.





## Preetha Bhadra and Atanu Deb

3. Ai, Z et al. Prevalence of anemia and its risk factors among children 6-36 months old in Burma. *Am J Trop Med Hyg.*87 (2), 306-11 (2012).
4. A.Saratha , Z. Singh , S.S Datta, *Indian journal of maternal and child health* ,2010, oct-dec , 12(4), 1-8.
5. A.H .Sultan , J . *Egypt Public Health Association* , 2007, 82, (3-4), 1-8.
6. Atkinson MA, Melamed ML, Kumar J, Roy CN, Miller ER, 3rd, Furth SL et al. Vitamin D, race, and risk for anemia in children. *J Pediatr.* 2014;164(1):153–8.e151. doi:10.1016/j.jpeds.2013.08.060.
7. Brown KH, Wuehler SE, Peerson JM: The importance of zinc in human nutrition and estimation of the global prevalence of zinc deficiency . *Food and Nutrition Bulletin* 2001, 22(2): 113-125.
8. Bano R , Mishra A, Ahma N. Study of nutritional anemia in the medical students of hind institute of medical sciences , Barabanki. *JARMS*2012 ; 4(2): 101-103.
9. Baig AK ,Saeed M . *European Journal of Economics , Finance and Administrative Sciences – Issue 48* (2012).
10. Black , R. E. et al. Maternal and child under nutrition : global and regional exposures and health consequences. *The Lancet.* 371, 243-60(2008).
11. Chaturvedi D et al. Study of correlation between dietary habits and anemia among adolescent girls in Ranchi and its surrounding area . *Int J contemp Pediatr* . 2017 ;4(4) : 1165-1168.
12. Calis, J.C.J. et al. Severe anemia in Malawian children . *N Engl J Med.* 358(9), 888-99 (2008).
13. Domellof M ,Dewey KG , Lonnerdal B, Cohen RJ, Hernell O : The diagnostic criteria for iron deficiency in infants should be reevaluated. *J Nutr* 2002, 132(12):3680-3686.
14. EmondAM ,Hawkins N , Pennock C , Golding J: Hemoglobin and ferritin concentration in infants at 8 months of age . *Arch Dis Child* 1996, 74(1): 36-39.
15. Fishman SM, Christian P , West KP: The role of vitamins in the prevention and control of anemia. *Public Health Nutr* 2000, 3(2):125-150.
16. Gallium RF. Association of serum ferritin and indices of body fat distribution and obesity in Mexican American men-the third national health and nutrition examination survey .*Int J ObesRelatMetabDisord* 2001 ;25(5): 639-645.
17. G.Kaur , J. Chhatwal, M.Verma, *Indian pediatric*, 1998, 35(12),1181-86.
18. Harper, J.L., Marcel, E.C. and Emmanuel, C. B., 2015. Iron Deficiency Anemia:Practice essentials, Pathophysiology and Etiology.Medscape. <http://www.health24.com/Medical/Anaemia/Anaemia-20130216-2,20113> .
19. Hercberg S, Rouaud C. Nutritional anaemia . 1981 ;(133) : 1-36 . PMID-1226458
20. Hurtado, E.K., Claussen , A.H. & Scott , K.G.Early childhood anemia and mild or moderate mental retardation .*Am J ClinNutr.* 69(1), 115-9(1999).
21. International II for PS-I and M. National Family Health Survey (NFHS-3), 2005-2006:Key Findings. Mumbai ,India. 2007.
22. ICF International , International Institute for population sciences (India) M of H and FW (India). 16. ICF International , International Institute for population sciences (India),Ministry of health and Family Welfare (India). *India Demographic and Health Survey 2015-2016*(Fairfax, United States;2018).
23. Jawed S, Tariq S , Kamal A. Frequency of nutritional anemia among female medical students of Faisalabad. *Pak J Med Sci.* 2017 Mar-Apr ;33(2):398-403.
24. Kanako Hisa, Megumi Haruna, naoko Hikita, emi Sasagawa, Kaori Yonezawa , Maiko Suto & erika ota. prevalence of and factors related to anemia among Japanese adult women: Secondary data analysis using health check-up database. *Scientific Reports* ,(2019) 9:17048 <https://doi.org/10.1038/s41598-019-52798-y>.
25. Kathryn L. Beck, Cathryn A. Conlon, Dietary determinants of and possible solutions to iron deficiency for young women living in industrialized countries : A Review *Nutrients* 2014; 6: 3747-3776.
26. Kobayashi, F. Television viewing and fast food intake of American and Japanese college students. *Nutrition and food science.* 2010; 40(2): 204-8.
27. Kumar , A. National nutritional anemia control programme in India. *Indian Journal of Public Health* . 43, 3-51(999).
28. Kirkwood, B.B. & Sterne, J. *Essential medical statistics.* Malden, MA: 1-512. (Blackwell Science.2003).







## Preetha Bhadra and Atanu Deb

29. Levy RB , Castro IRR, Cardoso LO, Tavares LF, Sardinha LMV, Gomes FS, et al. Food consumption and eating behavior among Brazilian adolescents: National Adolescent School based Health Survey (PeNSE), 2009. CiAncSaC de Coletiva 2010; 15(Suppl. 2): 3085-3097.
30. Mehta K. Prevalence of nutritional anemia among college students and its correlation with their body mass index. Int J Sci Res. 2015; 4: 1882-1886.
31. McLean E, Cogswell M, Egli I, et al. (2009). Worldwide prevalence of anaemia, WHO Vitamin and Mineral Nutrition Information System, 1993–2005. *Public Health Nutrition*.12:444-454.
32. M.C. Patil, S. Shailja, V. Algeer, International journal of current research & review, 2011, 3(11), 80.
33. Nupura A. Vibhute,UnnatiShah , UzmaBelgaumi, VidyaKadashetti, SushmaBommanavar , WasimKamate. DOI: 10.4103/jfmpc.jfmpc\_353\_19.
34. Nkechi G. onyeneho, Benjamin C. ozumba & S. V. Subramanian. Determinants of childhood Anemia in India. Scientific Repots (2019) 9:16540 | <https://doi.org/10.1038/s41598-019-52793-3>
35. Osorio MM, Lira PI, Bastista-FilhoM , Ashworth A : Prevalence of anemia in children 6-59 months old in the state of pernambuco, Brazil. Rev PanamSaludPublica 2001, 10(2):101-107.
36. O’Broin SD, Gunther EW : Screening of folate status with use of dried blood spots on filter paper. Am J ClinNutr 1999, 70(3):359-367.
37. Pollitt E, Saco-Pollitt C, Leibel FE: Iron deficiency and behavioral development in infants and preschool children. Am J ClinNutr 1986, 43(4): 555-565.
38. Panat AV. Iron deficiency among rural college girls: A result of poor nutrition and prolonged menstruation, JCNH. 2013 ;2(2) : 56-60.
39. Pasricha, S.R. et al. Determinants of anemia among young children in rural India. Pediatrics . 126(1), e140-9(2010).
40. Qin YU ,Boonstra AM et al. Anemia in relation to body mass index and waist circumference among Chinese women. Nutrition Journal 2013, 12:10.
41. Rivera-Dommarco J, Shamah-Levy T ,Villalpando-Hernandez S, Gonzalez-de Cossio T, Hernandez-Prado B, Sepulveda J: EncuestaNacional de Nutricion 1999. Estado nutricional de niños y mujeres en Mexico.
42. R.C. Paul, Journal of population and social studies ,2010,19(1),2806.
43. Rohner F, Zimmermann MB, Wegmueller R, Tschannen AB, Hurrell RF. Mild riboflavin deficiency is highly prevalent in school-age children but does not increase risk for anaemia in Cote d’Ivoire. Br J Nutr. 2007;97(5):970–6. doi:10.1017/s0007114507665180.
44. SalgueiroMJ ,Zubillaga M , Lysionek A, Cremaschi G, Goldman CG, Caro R, De Paoli T, Hager A , Weill R, J.B: Zinc status and immune system relationship: a review. Biol Trace Res 2000, 76(3):193-205.
45. S. R. Kane ,Digvijay Gotapagar, Rajashri Gorad, and C. S. Magdum . Estimate the prevalence of anemia among women in Women College and influence of socio-economic- demographic factors . Advances in Applied Science Research, 2016, 7(4):150-152 .
46. Sturgis P: Analyzing Complex Survey Data: Clustering, Stratification and Weights. Social Reseach UPDATE 2004:2-5.
47. Stoltzfus RJ:Defining irondeficiencyanemia in public health terms: a time for reflection. J Nutr 2001,131(2S-2):565S-567S.
48. Sandstrom B: Diagnosis of zinc deficiency and excess in individual and populations. Food and Nutrition Bulletin 2001,22(2): 133-136.
49. Sachdev,H., Gera ,T. &Nestal, P. Effect of iron supplementation on mental and motor development in children : systematic review of randomized controlled trials. Public Health Nutr . 8(2), 117-32(2005).
50. Soundarya, N et.al JOSTI-Vol-1-1-November-2016: 10- 17 . Journal of science and technology investigation -ISSN: 2456-8082
51. Thankachan , P.,Walczyk, T., Muthayya, S., Kurpad, A.V. &Hurrell,R.F. Iron absorption in young Indian women: The interaction of iron status with the influence of tea and ascorbic acid 1-3.Am J Chin Nutr . 87(4),881-6(2008).
52. Thurlow, R. et al. Only a small proportion of anemia in northeast. Thai school children is associated with iron deficiency. Am J Chin Nutr . 82, 380-7(2005).





**Preetha Bhadra and Atanu Deb**

53. Umeta M , West CE, Haider J , Deurenberg P, Hautvast JG: Zinc supplementation and stunted infants in Ethiopia: a randomized controlled trial. Lancet 2000, 355(9220): 2012-2026.
54. UNICEF/UNU/WHO Consultation : Iron deficiency anemia: Assessment, prevention and control. A guide for programme managers. World Health Organization;2001:38.
55. Van Nhien , N. et al. Relationship of low serum selenium to anemia among primary school children living in rural Vietnam (internet). Vol. 54, Journal of Nutritional Science and Vitaminology. 54,454-9(2008).
56. Virgil F. (2011). Fairbanks et al. Iron metabolism.In Hematology [William J. Williams et al., 8th edition.], Part II, chap. 9, New York: Mcgraw-Hill book company.
57. World Health Organization . Iron Deficiency Anemia: Assessment, Prevention and Control, A guide for program managers. Who Guide,1-114(2001).
58. Wharton, B.A. Iron deficiency in children : Detection and Prevention. Vol . British Journal of Hematology .106,207-80(1999).
59. Walter T, De Andracaal ,Chadud P, Perales CG: Iron deficiency anemia : adverse effects on infant psychomotor development. Pediatrics 1989,84(1):7-17.
60. Zetterstrom R: Iron deficiency and iron deficiency anemia during infancy and childhood. ActaPaediatr 2004,93(4):436-439.

**Table 1: Normal hemoglobin level (g/dl)**

Male	
Age 12-18 years	13.0 to 16.0(mean 14.5)
Age >18 years	13.6 to 17.7 (mean 15.5)
Female	
Age 12-18 years	12.0 to 16.0 (mean 14.0)
Age >18 years	12.1 to 15.1 (mean 14.0)
Children	
Birth	13.5 to 24.0( mean 13.9)
Age < 1month	10.0 to 20.0 (mean 13.9)
2-6 months	9.5 to 14.0 (mean 12.6)
6 months- 2 years	10.5 to 13.5 (mean 12.0)
2-6 years	11.5 to 13.5 (mean12.5)

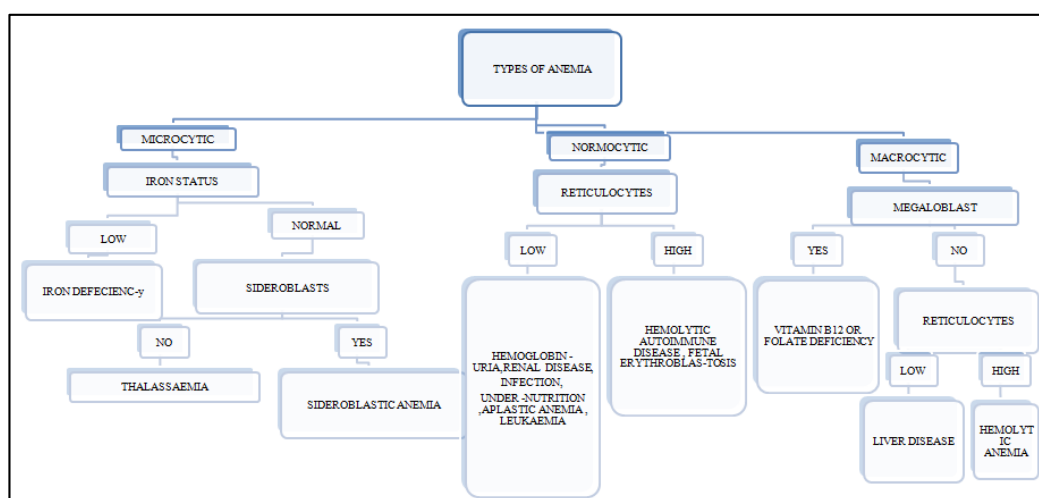

**Fig 1: Types, diagnostics features and differential diagnoses of anemia**





## A Study on the Determination of Phenol, Flavonoid Content and Antioxidant Potential of *Manihot esculenta* L. Tuber

G. Latha<sup>1</sup>, M. Veerapagu<sup>2\*</sup>, K. Ramanathan<sup>2</sup> and K.R. Jeya<sup>1</sup>

<sup>1</sup>Department of Biotechnology, Bharathidasan University Constituent Model College (W), Veppur, Perambalur, Tamilnadu, India.

<sup>2</sup>Assistant Professor, Department of Microbiology, Thanthai Hans Roever College (Autonomous), Elambalur, Perambalur, Tamil Nadu, India.

Received: 13 Jan 2020

Revised: 19 Feb 2020

Accepted: 21 Mar 2020

### \*Address for Correspondence

#### M. Veerapagu

Assistant Professor,  
Department of Microbiology,  
Thanthai Hans Roever College (Autonomous),  
Elambalur, Perambalur,  
Tamil Nadu, India.  
Email: mveerapagu@gmail.com



This is an Open Access Journal / article distributed under the terms of the **Creative Commons Attribution License (CC BY-NC-ND 3.0)** which permits unrestricted use, distribution, and reproduction in any medium, provided the original work is properly cited. All rights reserved.

### ABSTRACT

In the present study, *Manihot esculenta* L. tuber was analysed for specific gravity, dry matter content and starch content. The results showed that the specific gravity was  $1.123 \pm 0.107$ , dry matter content was  $34.62 \pm 0.65\%$  and starch content was  $23.32 \pm 1.02\%$ . The tuber was extracted with methanol by soxhlet extraction method and investigated for the amount of total phenol content (TPC), total flavonoid content (TFC) and antioxidant activity by DPPH radical scavenging assay. It was found that the total phenol content was  $10.46 \pm 0.79$  mg GAE/g, total flavonoid content was  $2.78 \pm 0.37$  mg QCE/g, the DPPH scavenging activity inhibition percentage was 91.42% and the IC<sub>50</sub> value was 0.44 mg/ml. The antioxidant activity of the tuber might be attributed to its polyphenolic content and flavonoid content.

**Keywords:** *Manihot esculenta*, TPC, TFC, DPPH, Specific gravity, dry matter content..

### INTRODUCTION

Tuber crops are important group of staple food in the tropical world [1]. There are five major groups of root and tuber crops cultivated across the world viz. Cassava (*Manihot esculenta*), Sweet potato (*Ipomoea batatas*), Potato (*Solanum tuberosum*), Yams (*Dioscorea* sp.) and edible Aroids (*Colocasia esculenta* and *Xanthosoma* sp.) known variously as Taro (*Colocasia*) and Tannia (*Xanthosoma*) [2]. Cassava (*Manihot esculenta* L.) is a dicotyledonous perennial plant [3]. The root tuber is composed of about 62% water, 35% carbohydrate, 1-2% protein, 0.3% fat, 1-2% fibre, and 1%

18682



**Latha et al**

mineral matter[4,5]. Cassava is used as a basic food staple for human consumption, starch source, and also for animal feed [6]. It is mainly consumed as boiled tuber or flour obtained by processing the root. The roots are very rich in carbohydrates, mainly starch (about 80% dry weigh). They also contain vitamin C, beta-carotene, calcium, potassium, and food fibres, but are very low in protein (0.5-1.5% fresh weight) [7].

There are different forms of processed cassava tuber like meal, flour, chips and starch [8]. The meal and flour forms account for the bulk of cassava used for human food in the tropics. Cassava chips and cassava starch are mainly industrial products that are little used for direct human consumption [9]. There is a high demand for starch in industry, and cassava starch has been used to fill part of this demand. The production of cassava starch for industrial use is a highly specialized and highly mechanized process. Sago is essentially cassava starch produced by a special process. In India nearly 60% of cassava is used industrially in the production of sago, starch and dry chips [10]. In Tamil Nadu several modified starches are manufactured from cassava which include pre-gelatinized starch (for the confectionery and textile industries), oxidized and cationic starches (for the paper industry), textile grade modified starch with good tensile and adhesive strength (for the textile industry), and paper grade starch with ink water resistance etc [11,12].

Plant based antioxidant rich foods traditionally formed a major part of the human diet, They play a vital role in maintaining human health [13]. Now-a-days plants with antioxidant properties are attractive sources of new drugs [14]. Thousands of herbal and traditional compounds are being screened worldwide to validate their use as antioxidants [15]. Foods rich in antioxidants could have a reduced risk of many diseases, such as cancer, cardiovascular diseases, chronic diseases and aging, among others [16,17]. The search for antioxidants from natural resources have received much attention and efforts have been put into identify compounds that can act as suitable antioxidants to replace synthetic antioxidant [18, 19]. In addition these naturally occurring antioxidants can be formulated to give nutraceuticals that can help to prevent oxidative damages and resulting diseases [20,21]. Hence in the present study *Manihot esculenta* tuber was investigated for physicochemical properties, phytochemicals and antioxidant activity.

## MATERIALS AND METHODS

### Collection and authentication of plant Tuber

The tuber of tapioca *Manihot esculenta* L. was collected from Uzhavar sandhai, Perambalur, Tamilnadu was used for the study. The plant tuber was identified and authenticated at Hans Roever KVK, Valikandapuram, Perambalur, Tamilnadu-621115 was confirmed with different floras [22,23] and documented properly.

### Gravity determination

The tubers were peeled and thoroughly cleaned with water to get rid of all soil particles on the tubers. The ends of the tubers were nicely trimmed to get a uniform shape. The washed tubers were then air-dried and weighed in air in a balance to make the total weight exactly to 200gm. The air weighed 200gm tubers were then immersed in clean water weight was noted down. The specific gravity was calculated by the formula [24].

Specific gravity = Weight of tuber / loss of weight in water

### Dry matter content

Tuber was trimmed as above and cut into small pieces to get uniform sizes. Fresh weight of about 50 gm of tuber was taken in a beaker and weighed. Then it was kept at 80oC in a hot air oven for six hours and then at 65oC till constant dry weight. Then again weighed and dry matter content was calculated [25].





### Determination of starch content percentage

Starch content of cassava tuber was determined by specific gravity method [26]. The specific gravity was determined as above and starch content was calculated by the formula.

Starch (%) = (210.8x SG) – 213.4.

### Extraction

The tuber of tapioca collected was washed in running water to remove adhering soil particles. The outer skin was peeled off and the tuber was cut into small pieces and dried in shadow. Then it was grinded into fine powder in a mixer grinder. About 50gm of tuber powder was extracted with methanol using soxhlet apparatus [27]. The extract was concentrated by evaporation under room temperature and used for the further study.

### Determination of total phenol content

Total phenol content was determined by using Folin Ciocalteu reagent method [28]. *Manihot esculenta* L. tuber methanolic extract 1ml (1mg/ml) was mixed with 5ml of Folin Ciocalteu's reagent (diluted with distilled water 1:10) and 4ml of sodium carbonate (1M). The mixture was allowed to stand for 30 mins at 40°C for development of colour. The absorbance was read at 765nm in a UV-Vis Spectrophotometer. The standard curve was prepared using 20, 40,60, 80 and 100 mg /l solution of gallic acid. The total phenol content were expressed as mg/g of gallic acid equivalents per gram of extract [29].

### Determination of total flavonoid content

The total flavonoid content (TFC) of methanolic extract was investigated using the aluminum chloride colorimetry method described by Do et al [30]. 2014 with slight modifications. To the 2ml of the extract (1mg/ml) in methanol was mixed with 0.1ml 0.1 ml of 10% (w/v) aluminum chloride solution and 0.1 ml of 0.1 mM potassium acetate solution. The mixture was kept at room temperature for 30 minutes. Then the maximum absorbance of the mixture was measured at 415 nm using a UV-VIS spectrophotometer. Quercetin 1 to 5mg/l was used as standard. TFC was expressed as milligram quercetin equivalent per gram (mg QCE/g dry weight [31].

### DPPH Radical Scavenging activity

The antioxidant activity of *Manihot esculenta* L. tuber methanol extract was assessed by the DPPH assay [32]. Five different concentration (25, 50,100,150, 200 µg/ml) of standard ascorbic acid was prepared from stock 1mg/ml and five different concentration of sample (0.125 mg/ml, 0.250 mg/ml, 0.500 mg/ml, 1.0 mg/ml and 2.0 mg/ml) was prepared from stock 2mg/ml of methanolic tuber extract. Reaction mixture containing 1.0 ml DPPH solution and 2.0 ml of different concentration of sample solution was incubated for 30 mins at room temperature in dark and absorbance was read at 517nm against blank. DPPH solution and methanol served as control. Similarly scavenging activity of ascorbic acid was determined as above. Radical scavenging activity was expressed by the inhibition percentage (I%) of DPPH radical as

Inhibition % = [(Ac-As)/Ac] x 100

Where, Ac and As are the absorbance of the control and of the test/standard /sample respectively. From a plot of concentration against I%, a linear regression analysis was performed to determine the IC<sub>50</sub> [33].





Latha et al

## RESULTS AND DISCUSSION

*Manihot esculenta* L. is one of the most important root crops worldwide [34, 35]. The edible root supplies energy for more than 500 million people [36]. The tuber of the cassava plant can be processed into many different products [37].

### Specific gravity

Specific gravity of cassava is commonly used by the cassava processing industry as a tool for quick estimation of dry matter content. In this study the specific gravity of cassava tuber was found to be  $1.123 \pm 0.107$  (Table 1). This shows that the tubers are denser than water and the values obtained agrees with [38]. Relationship between specific gravity and dry matter content of cassava has been developed by several workers [24, 39,40] and this relationship has been found to vary with the variety, location, season and the year of cultivation.

### Dry matter content

Dry matter content percentage of *Manihot esculenta* tuber was  $34.62 \pm 0.65\%$  (table 1 & figure.1) This result was similar to Braima *et al.* [41]. Who reported that the dry matter content of cassava tuber was above 1.0, the specific gravity of cassava tubers versus the dry matter content. It revealed that the dry matter content of cassava tubers depends on the specific gravity and vice versa. This means that as the specific gravity increases the dry matter content also increases and vice versa, this trend was not different from the study conducted by Asare [42]. Fakir et al [43] investigated the dry matter content of seven varieties of cassava tuber and reported that average dry matter of tuber varied from 37.30% to 45.26%.

### Starch content

The cassava plant gives the third-highest yield of carbohydrates per cultivated area among crop plants, after sugarcane and sugar beets. Cassava plays a particularly important role in agriculture in developing countries, especially in sub-Saharan Africa, In the present study the starch content of *Maniholt esculenta* was determined by tuber specific gravity method. It was found that the starch (%) of tuber was  $23.32 \pm 1.02\%$  ( table 1 & figure.1). This result was in similar agreement with the result of Ezeigbo et al. [44], who reported the starch % of three variety of cassava tubers were 17.48%, 20.62% and 21.70%. Similarly Prammane *et.al.* [45] reported starch content of different cassava cultivars varied from 18.0% to 24.5%. They also suggested that the starch content depends on cultivar, harvest time and the planting/growing location [46]. Polanthee et al [47] found that starch content of cassava cultivars Kasetsart-50 and Rayong-72 were 25.9 and 19.1% respectively.

### Determination of total phenolic compounds

The total phenolic content was measured in terms of gallic acid equivalent using the Folin Ciocalteu reagent method. Total phenol content (TPC) content in the extract was calculated from the regression equation ( $Y= 0.0325X+0.11$ ,  $R^2= 0.9983$ ) of the calibration curve (Table.2) and is expressed as gallic acid equivalents (GAE). The total phenol content of methanolic extract of *Manihot esculenta* tuber was  $10.46 \pm 0.79$  mg GAE/g (Table 3 & figure.2). Khan et al. [48] reported that ethyl acetate showed the highest concentration of TPC which was  $13.47 \pm 0.56$  mg GAE/g, chloroform displayed TPC of  $7.52 \pm 0.09$  mg GAE/g and hexane displayed TPC of  $5.35 \pm 0.66$  mg GAE/g. Similarly Linn et al. [49] reported that the average values of phenolic compounds content in ethanol extract ( $784.22 \mu\text{g GAE per mg}$ ) were approximately two times higher than that in aqueous extract ( $446.22 \mu\text{g GAE per mg}$ ). The great differences in the contents of phenolic compounds in different extracts indicate that less polar phenolic compounds form the most important part of the phenolic compounds in ethanol extract.





Latha et al

### Determination of total flavonoid content

Flavonoid content was calculated from the regression equation ( $Y= 0.15X+0.002$ ,  $R^2= 0.9996$ ) of the calibration curve (Table.2) and is expressed as Quercetin equivalents (QE). Flavonoid content of the plant tuber extracts was expressed as mg quercetin equivalents per gram dried weight (mg QE/g dried weight). Total flavanoid content of *Manihot esculenta* tuber methanolic extract was found to be  $2.78\pm 0.37$ mg QCE/g dry weight (Table.3& figure.2). Mehran et al., [28] reported that flavonoid content of aqueous extract of *Manihot esculenta* was 1.27 mg QCE/g . Similarly Khan et al., [48] reported that total flavonoid content of *M.esculenta* ethyl acetate extract is the higher ( $6.66 \pm 0.94$  mg QE/g) than chloroform extract ( $2.69 \pm 0.09$  mg QE/g) and hexane ( $0.89 \pm 0.17$  mg QE/g).

Flavonoids are naturally occurring compounds which have a polyphenolic structure [50]. They mainly occur in a plant as sugar derivatives known as glycosides [51]. Antioxidant and cardioprotective effect of flavonoids are attributed to the ability to inhibit lipid peroxidation, chelate redox active metals and attenuate other processes involving reactive oxygen species [52,53].

### DPPH Radical Scavenging activity

The antioxidant activity of *Manihot esculenta* tuber methanolic extract was determined by DPPH radical scavenging assay. The reduction of DPPH radical was determined by the decrease in its absorbance at 517nm, induced by antioxidants, due to the reaction between antioxidant molecules and radicals, which in turn results in the scavenging of the radical by hydrogen donation [54]. It is visually noticeable as a change in colour from purple to yellow [55]. The percentage of inhibition of DPPH in different concentration of 0.125 mg/ml, 0.250 mg/ml, 0.500 mg/ml, 1.0 mg/ml and 2.0 mg/ml were 14.3, 25, 57.14, 75 and 91.42% for methanolic extract and the IC<sub>50</sub> value was 0.44 mg/ml ( figure. 3) .

The Percentage inhibition of ascorbic acid used as positive control were found to be 28.5,45.7, 64.3, 71.6 and 95.7% respectively. The IC<sub>50</sub> value of ascorbic acid was 57.62 µg/ml (figure. 3). Linn et al [49] reported that radical scavenging activity of different extracts of *Manihot esculenta* was lower than the standard. Omar et al [56] observed that the DPPH scavenging activity of two cassava varieties Medan and sri Pontian were 47.58% and 37.11% and they also found that the percentage of inhibition increases with use of fertilizer 67.3% and 54.7%.

## CONCLUSION

The results of this study revealed the dry matter content, specific gravity, starch content, total flavonoid content, total phenol content and DPPH scavenging activity of *Manihot esculenta* tuber. It could be concluded that the cassava tuber is a nutritious root tuber and provide nutraceuticals potential for the treatment of malnutrition and prevention of oxidative stress related diseases.

## REFERENCES

1. Nayar NM. The contribution of tropical tuber crops towards food security. Journal of Root Crops. 2015; 40(1): 3-14.
2. Shewry PR. Tuber storage proteins. Annals of botany.2003; 91(7): 755-769.
3. Medina RD, Faloci MM, Gonzalez AM, Mroginski LA. In vitro cultured primary roots derived from stem segments of cassava (*Manihot esculenta*) can behave like storage organs. Annals of botany. 2007; 99(3): 409–423.





## Latha et al

4. Afoakwa EO, Asiedu C, Budu AS, Chiwona-Karlton L, Nyirendah DB. Chemical composition and cyanogenic potential of traditional and high yielding CMD resistant cassava (*Manihot esculenta* Crantz) varieties. International Food Research Journal. 2012; 19(1): 175-181.
5. Morgan NK, Choct M. Cassava: Nutrient composition and nutritive value in poultry diets. Animal Nutrition. 2016;2(4): 253-261.
6. Montagnac JA, Davis CR, Tanumihardjo SA. Nutritional value of cassava for use as a staple food and recent advances for improvement. Comprehensive reviews in food science and food safety. 2009; 8(3): 181-194.
7. Charles AL, Sriroth K, Huang TC. Proximate composition, mineral contents, hydrogen cyanide and phytic acid of 5 cassava genotypes. Food chemistry. 2005; 92(4): 615-620.
8. Sreenivasan T, Anaatharaman M. Cassava marketing systems in India. Technical bulletin series. 2005; 43, CTCRI, Thiruvananthapuram.
9. Treesilvattanakul, K. Deterministic Factors of Thai Cassava Prices: Multi-Uses of Cassava from Food, Feed, and Fuel Affecting on Thai Cassava Price Volatility. KnE Life Sciences.2016; 3(3): 12-16.
10. Srinivas, T. Industrial demand for cassava starch in India. Starch-stärke.2007; 59(10): 477-481.
11. Kathiravan, V, Saranya S, Kumar KSV, Rajasekar DD. Economics of Processing of Different Tapioca Based Products in Salem District of Tamil Nadu, India. Int. J. Curr. Microbiol. App. Sci. 2017; 6(11):1613-1619.
12. Yazid NYM, Abdullah N, Muhammad N, Monica HMP. Application of starch based products in food industry. Journal of science and technology. 2018;10(2): 144-174.
13. Slavin JL, Lloyd B. Health Benefits of Fruits and Vegetables. Advances in Nutrition. 2012; 3(4):506–516.
14. Amin A, Hamza AA. Hepatoprotective effects of *Hibiscus rosniarnus* and salvia on azathioprine-induced toxicity in rats. Life Sci. 2005; 77:266-278.
15. Kaushik P, Priyanka P, Kaushik DA. Comprehensive review on medicinal plants with anticancer activity. Global Journal of Pharmaceutical Education and Research. 2014; 3(1-2):1-13.
16. Hajhashemi V, Vaseghi G, Pourfarzam M, Abdollahi A. Are antioxidants helpful for disease prevention? Research in pharmaceutical sciences. 2010; 5(1): 1-8.
17. Wilson D, Nash P, Buttar H, Griffiths K, Singh R, De Meester F. et al. The role of food antioxidants, benefits of functional foods, and influence of feeding habits on the health of the older person: an overview. Antioxidants. 2017; 6(4): 81.
18. Taghvaei M, Jafari SM. Application and stability of natural antioxidants in edible oils in order to substitute synthetic additives. Journal of food science and technology.2015; 52(3): 1272-1282.
19. Asif M. Chemistry and antioxidant activity of plants containing some phenolic compounds. Chemistry international. 2015; 1(1): 35-52.
20. Nasri H, Baradaran A, Shirzad H, Rafeian-Kopaei M. New concepts in nutraceuticals as alternative for pharmaceuticals. Int.J. Prev. Med. 2014;5(12): 1487-1499.
21. Lee MT, Lin WC, Yu B, Lee TT. "Antioxidant capacity of phytochemicals and their potential effects on oxidative status in animals—A review." Asian-Australasian journal of animal sciences 2017; 30(3): 299–308.
22. Verma DM, Balakrishnan, NP, Dixit RD. Flora of Madhya Pradesh Botanical Survey of India. *Calcutta*. (1997).Vol. II.
23. Naik VN. Flora of Marathwara . Amrut prakashan Aurangabad. 1998; vol. I.
24. Teye E, Asare AP, Amoah RS, Tetteh JP. Determination of the dry matter content of cassava (*Manihot esculenta*, Crantz) tubers using specific gravity method. ARPN Journal of Agricultural and Biological Science. 2011; 6(11): 23-28.
25. Kumar D, Ezekiel R, Singh B, Ahmed, I. Conversion table for specific gravity, dry matter and starch content from under water weight of potatoes grown in North-Indian plains. Potato Journal. 2005; 32(1-2): 79-84.
26. Khanthavong P, Phattarakul N, Jamjod S, Aye TM, Rerkasem B. Effect of stake priming with complete nutrient solution on cassava root and starch yield. *CMU. J. Nat. Sci. Special Issue on Agricultural and Natural Resources*. 2012; 11(1): 75-80.







## Latha et al

27. Redfern J, Kinninmonth, M, Burdass D, Verran J. Using Soxhlet ethanol extraction to produce and test plant material (essential oils) for their antimicrobial properties. *Journal of microbiology & biology education*.2014; 15(1): 45–46.
28. Mehran MJ, Zendeabad SH, Malla S, Free radical scavenging and antioxidant potential activity of cassava plants. *Asian J Pharm Clin Res*. 2014;7(1): 66-70.
29. Madaan R, Bansal G, Kumar S, Sharma A. Estimation of Total Phenols and Flavonoids in Extracts of *Actaea spicata* Roots and Antioxidant Activity Studies. *Indian journal of pharmaceutical sciences*. 2011;73(6): 666–669.
30. Do QD, Angkawijaya AE, Tran-Nguyen PL, Huynh LH, Ju YH. Effect of extraction solvent on total phenol content, total flavonoid content, and antioxidant activity of *Limnophila aromatica*. *Journal of food and drug analysis*.2014;22(3): 296-302.
31. Priya SH, Prakasan N, Purushothaman J. Antioxidant activity, phenolic-flavonoid content and high-performance liquid chromatography profiling of three different variants of *Syzygium cumini* seeds: a comparative study. *Journal of intercultural Ethnopharmacology*. 2017; 6(1): 107–114.
32. Veerapagu M, Jeya KR, Sankaranarayanan A, Rathika A. In vitro antioxidant properties of methanolic extract of *Solanum nigrum* L. fruit. *The Pharma Innovation*. 2018; 7(5): 371-374.
33. Gupta M, Karmakar N, Sasmal S. In vitro antioxidant activity of aqueous and alcoholic extracts of polyherbal formulation consisting of *Ficus glomerata* Roxb. and *Symplocos racemosa* Roxb. stem bark assessed in free radical scavenging assays. *Int J Pharmacog Phytochem Res* 2017; 9; 181-189.
34. Burns A, Gleadow R, Cliff J, Zacarias A, Cavagnaro T. Cassava: the drought, war and famine crop in a changing world. *Sustainability*. 2010; 2(11): 3572-3607.
35. Nuwamanya E, Baguma Y, Kawuki RS. and Rubaihayo PR. Quantification of starch physicochemical characteristics in a cassava segregating population. *African Crop Science Journal*. 2009;16: 191-202.
36. Ceballos H, Sánchez T, Chávez AL, Iglesias C, Tohme J. Variation in crude protein content in cassava (*Manihot esculenta* Crantz) roots. *Journal of Food Composition and Analysis* 2006;19(6-7): 589-593.
37. Abu JO, Badifu GIO, Akpapunan MA. Effect of Crude palm-oil inclusions on some physico-chemical properties of gari, a fermented cassava food product. *Journal of Food Science and Technology*.2006; 24: 73- 79.
38. NRI. Methods for assessing quality characteristics of non-grain starch staples. 1996. part 2. Field methods. Natural Resources Institute, UK.
39. Cuvaca IB, Eash N, Zivanovic S, Lambert DM, Rustrick B. Cassava (*Manihot esculenta* Crantz) tuber quality as measured by starch and cyanide (HCN) affected by nitrogen, phosphorus, and potassium fertilizer rates. *Journal of Agricultural Science*. 2015;7(6): 36- 49.
40. Karlström A, Calle F, Salazar S, Morante N, Ceballos H. Biological Implications in Cassava for the Production of Amylose-Free Starch: Impact on Root Yield and Related Traits. *Frontiers in plant science*. 2016;7: 604.
41. Braima J, Neuenschwander H, Exhendu N, Toko M. Pest Control in Cassava farms: IPM Field Guide for Extension Agents. Wordsmiths Printers, Lagos, Nigeria.2000; p. 36.
42. Asare AP. Determination of dry matter content of cassava tubers. B.Sc dissertation, University of Cape Coast. Cape Coast, Ghana. 2004; p. 34.
43. Fakir MSA, Jannat M, Mostafa MG . Seal, H. Starch and flour extraction and nutrient composition of tuber in seven cassava accessions. *Journal of the Bangladesh Agricultural University*. 2012; 10(2): 217-222.
44. Ezeigbo OR, Ukabi CF, Ike-Amadi, CA, Ekaiko MU. Determination of Starch and Cyanide Contents of Different Species of Fresh Cassava Tuber in Abia State, Nigeria. *British Biotechnology Journal*. 2015; 6(1): 10.
45. Prammanee S, Kamprerasart K, Salakan S, Sriroth K. Growth and starch content evaluation on newly released cassava cultivars, Rayong 9, Rayong 7 and Rayong 80 at different harvest times. *Kasetsart Journal (Natural Science)*. 2010; 44; 558-563.
46. Suja G, John KS, Sreekumar J, Srinivas, T. Short-duration cassava genotypes for crop diversification in the humid tropics: growth dynamics, biomass, yield and quality. *Journal of the Science of Food and Agriculture*. 2010; 90(2): 188-198.
47. Polthanee A, Janthajam C, Promkhambut A. Growth, yield and starch content of cassava following rainfed lowland rice in Northeast Thailand. *Int J Agric Res*. 2014; 9(6) 319-324.





**Latha et al**

48. Khan MS, Yusufzai SK, Kimin L, Jabi NA Determination of Chemical Composition, Total Flavonoid Content, Total Phenolic Content and Antioxidant Capacity of Various Crude Extracts of *Manihot esculenta* Crantz Leaves. International Journal for Research in Applied Science & Engineering Technology. 2018; 6(IV): 2433-2443.

49. Linn KZ, Myint PP. Estimation of nutritive value, total phenolic content and in vitro antioxidant activity of *Manihot esculenta* Crantz. (Cassava) leaf. Journal of Medicinal Plants. 2018;6(6): 73-78.

50. Panche AN, Diwan AD, Chandra SR. Flavonoids: an overview. Journal of nutritional science. 2016; 5:e47.

51. Karak P. Biological activities of flavonoids:An overview. International Journal of Pharmaceutical sciences and research. 2019; 10(4): 1567-1574.

52. Cao G, Sofic E, Prior RL. Antioxidant and prooxidant behavior of flavonoids: structure activity relationships. Free Radical Biology and Medicine. 1997; 22(5):749-760.

53. Pietta PG. Flavonoids as antioxidants. Journal of Natural Products. 2000; 63(7):1035-1042.

54. Bhalodia NR, Nariya PB, Acharya RN, Shukla VJ. In vitro antioxidant activity of hydro alcoholic extract from the fruit pulp of *Cassia fistula* Linn. Ayu. 2013; 34(2): 209-214.

55. Ganaie AA, Mishra RP, Allaie AH. Antioxidant activity of some extracts of *Iris ensata*. Journal of Pharmacognosy and Phytochemistry, 2018; 7(2): 230-235.

56. Omar NF, Hassan SA, Yusoff UK, Abdullah NAP, Wahab PEM, Sinniah UR. Phenolics, flavonoids, antioxidant activity and cyanogenic glycosides of organic and mineral-base fertilized cassava tubers. Molecules. 2012; 17(3): 2378-2387.

**Table 1. characteristics of *Maniholt esculenta* L.tuber**

Specific gravity	1.123± 0.107
Dry matter content (%)	34.62 ± 0.65%
Starch content (%)	23.32 ± 1.02%

**Table 2. Linear equations and their R<sup>2</sup> values obtained from the standard calibration curves**

Assays	Calibration curve	R <sup>2</sup>
TPC	Y= 0.0325X+0.11	0.9983
TFC	Y= 0.15X+0.002	0.9996

**Table 3. Total flavonoid, Phenol content of *M. esculenta* tuber methanolic extract**

<i>M. esculenta</i> tuber	TFC (mg QAE /g)	TPC (mg GAE / g)
Methanol extract	2.78±0.37	10.46±0.79

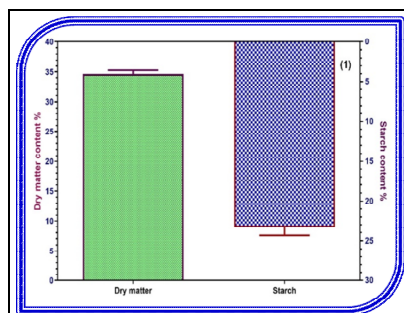

**Figure 1. Dry matter and starch content of *Manihot esculenta* tuber.**

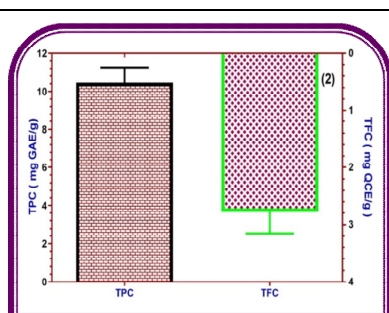

**Figure 2. Total phenol and Flavonoid content of *Manihot esculenta* tuber extract.**

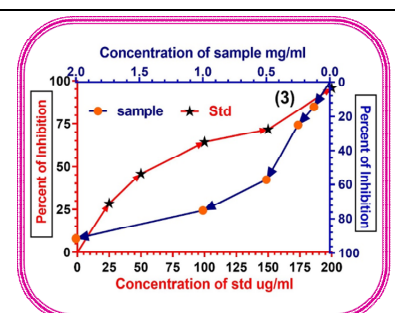

**Figure 3. Antioxidant activity of *M. esculenta* tuber methanolic extracts (Sample) and Ascorbic acid (standard).**





## Overview on Diethylnitrosamine Induced Hepatocellular Carcinoma Animal Model for the Biological Screening of Anticancer Herbal Medicines

Anjala Devi S<sup>1\*</sup>, Sivakumar G<sup>1</sup> and Gopalasatheeskumar K<sup>2</sup>

<sup>1</sup>Department of Pharmacology, KMCH College of Pharmacy (Affiliated to The Tamil Nadu Dr. M.G.R. Medical University), Kovai Estate, Kalapatti Road, Coimbatore, Tamil Nadu, India

<sup>2</sup>Research Scholar (Pharmacology), Department of Pharmacy, Annamalai University, Annamalai Nagar, Tamil Nadu, India

Received: 18 Jan 2020

Revised: 20 Feb 2020

Accepted: 23 Mar 2020

### \*Address for Correspondence

#### Anjala Devi S

Department of Pharmacology,  
KMCH College of Pharmacy (Affiliated to the Tamil Nadu Dr. M.G.R. Medical University),  
Kovai Estate, Kalapatti Road, Coimbatore,  
Tamil Nadu, India.

Email: mveerapagu@gmail.com



This is an Open Access Journal / article distributed under the terms of the **Creative Commons Attribution License** (CC BY-NC-ND 3.0) which permits unrestricted use, distribution, and reproduction in any medium, provided the original work is properly cited. All rights reserved.

### ABSTRACT

Cancer is a disease that evokes wide spread fear among people and is one of the leading causes of deaths in the world. Hepatocellular carcinoma (HCC) remains a leading cause of cancer-related death both in developed and under-developed countries. Many of the synthetic drugs (chemotherapeutics) but these are the chemotherapeutic agents associated with side effects. So that focusing of herbal and herbal medicine is alternative to chemotherapy. The research focused on screening of new molecules through *in vitro*, *in silico* and *in vivo* techniques. In *in vivo* screening method Diethylnitrosamine induced animal model is plays important role. Diethylnitrosamine (DEN) is a known carcinogen in rodent liver. DENs reported to undergo metabolic activation by cytochrome P450 enzymes to form reactive electrophiles that cause oxidative stress leading to cytotoxicity, mutagenicity and carcinogenicity. This review is focused on DEN induced animal models with anticancer herbal medicines.

**Key words:** DEN, *in vivo*, anticancer, carcinogen, phytomedicine.

### INTRODUCTION

Hepatocellular carcinoma (HCC) remains a leading cause of cancer-related death both in developed and under-developed countries(1). Liver cancer affects nearly 22,000 people in the united states and more than 18,000 deaths.



**Anjala Devi et al**

HCC is the fifth most common cancer and third leading cause of cancer mortality in the world (2). Approximately 5.6 lakh new causes are diagnosed each year and around 5.5 lakh deaths due to liver cancer occur mostly in developed countries (3). Tobacco and alcohol are established risk factor for hepatocellular carcinoma (HCC), the most common types of primary liver cancer, it is unknown whether they also increases risk of intra hepatic cholangiocarcinoma (HCC) thus, the associated between tobacco alcohol uses by primary liver cancer types (4,5). Hepatitis B and C alcohol consumption, hormone exposure, haemochromatosis, aflatoxin B1 and diethylnitrosamine (DEN) are the major risk factor for causing hepatocellular carcinoma (6). diethylnitrosamine is one of the most important environmental carcinogens, present in tobacco-smoke, cosmetics, gasoline and various processed food such as milk and meat products.

**Risk factors**

liver cancer include heavy alcohol consumption, hepatitis virus (HBV) hepatitis C virus, obesity, tobacco smoking, diabetes and genetic factors. toxic substances, hepatic injury resulted in the de generation and inflammation, leading to chronic liver disease, which may further propartices to different stages of fibrosis, cirrhosis and HCC.

**Treatment for liver cancer**

The incidence of high mortality and associated side effects following chemotherapy and or radio therapy increase the demand for alternative medicine for the causes of treatment, many anti cancer compounds were isolated from plant taxol, etoposide, vindesine, vinblastine, vincristine and topotecan.

**Plant used for liver cancer**

Medicinal plants are frequently used by traditional healers to treat a variety of ailments and symptoms including diabetes and cancer. According to world health organization, over 80% of the world's populations rely upon such traditional plant-based systems of medicine to provide them with primary healthcare (7).

***Terminalia chebula***

The fruit powder of *Terminalia chebula* is used in India to treat several diseases ranging from digestive, coronary disorders to allergic and infectious disease like cough and skin disorders. The researcher Srigopalram *et al.*, studied anticancer effect of *Terminalia chebula* against DEN induced hepatocellular carcinoma. The decrease in tumor markers after *Terminalia chebula* aqueous extract administration might due to decrease in the production rate of tumors (8).

***Madhula longifolia***

*Madhula longifolia* belongs to the family of sapotaceae. Leaves of *Madhula longifolia* are utilized as a vegetable in India. *Madhula longifolia* leaves are expectorant and further more utilized for treating chronic bronchitis, liver disease, cancer and cushings disease. The stem bark is utilized to cure skin maladies hydrocoele and skin infection. The tree is used by the tribal populations who are backwoods inhabitants and who distinctly monitor this tree. The extract of *Madhuma longifolia* contains different biomolecules including alkaloids, avonoids, phenols, tannins, glycosides, saponins, carbohydrates, proteins and enzymes, which act as a strong anti oxidant properties and prevent the oxidative damage to cellular apparatuses. The researchers Singh *et al.*, studied the *M.longifolia* leaf extract on diethylnitrosamine induced liver cancer in animal models (9,10).



**Anjala Devi et al*****Phoenix dactylifera* L**

*Phoenix dactylifera* L is rich sources of energy and readily provide sugars, proteins, vitamins, high dietary fibers, Minerals and fats. They contain various phytochemicals and fats like sterols, Polyphenols, flavonoids and glycosides. It has hypolipidemic, antioxidant, anti-inflammatory, cardioprotective, nephroprotective and hepatoprotective effects. The authors Baliga et al., reported anti-inflammatory, hepatoprotective and anti-cancer properties could be due to the presence of flavonoids such as luteolin, apigenin, quercetin and proanthocyanidins in *Phoenix dactylifera* L.(11).

***Canthium coromandelicum***

*Canthium coromandelicum* is belonging to family of Rubiaceae. *Canthium coromandelicum* leaves has antimicrobial, anti-HIV activity, hypocholeraemic activity, oral hypoglycemic activity, wound healing activity and antioxidant properties. It contains phytoconstituents include kaempferol 3-O-B-D- glycopyranoside, squalenes, phytol, beta-sitosterol and n-hexadecanoic acid. The author Thirupathi Anand et al., reported anticancer activity of this plant material against DEN induced rats. The *Canthium coromandelicum* treatment rats show upregulation of caspases-3 against DEN-induced rats (12).

***Vitis vinifera***

*Vitis vinifera* are rich in poly phenols (60-70%) found in the seeds. *Vitis vinifera* seed extract has high content of antioxidants in the form of flavonoids, polyphenols, and proanthocyanidins. *Vitis vinifera* seed extract is potent of cardioprotective, antibiotic, antimutagenic and anti-inflammatory properties. The authors Hamza et al., reported the anticancer activity of *Vitis vinifera* seed extract against DEN induced hepatocellular carcinoma in rats (13). *Vitis vinifera* seed extract can inhibit FAH formation in livers of DEN treated rats. *Vitis vinifera* seed extract were associated with induced apoptosis, reduced cell proliferation, decreased oxidative stress and down regulation of HDAC activity and inflammation makers such as COX-2, INOS, NK-KB -P65 and p-TNFR1 expressions.

***Sesbania grandiflora***

The authors Veerabhadrapa et al., has studied the anticancer potential of *Sesbania grandiflora* extracts against DEN-induced mice. The ethanolic extract of *Sesbania grandiflora* treatment on DEN induced hepatic cancer rats, exhibit anticancerous effect by enhanced activities of antioxidant enzymes (AST, ALT, GST, GPx, and CAT). The activity may be due to the presence of antioxidant property (14).

***Solanum villosum***

*Solanum villosum* leaf extract has various functional components, such as flavonoids, alkaloids, phenols and glycosides in the leaves could play an important role in altering body fat and regulating lipid metabolism. *Solanum villosum* leaf aqueous extract could have exerted their therapeutic effect against DEN induced hepatocellular carcinoma probably by preventing membrane damage, loss of integrity as well as by repairing hepatic tissue damage caused by tumor induction, thus inhibiting the release of these marker enzymes into the serum, indicating that *Solanum villosum* leaves has the ability to prevent further development of HCC. The treatment of *Solanum villosum* leaf aqueous extract effectively reduces the protein damage caused by DEN may be attributed by the radical scavenging effect and antioxidant activity of *Solanum villosum* leaves (15).



**Anjala Devi et al*****Garcinia mangostana* L.**

*Garcinia mangostana* L. (*Clusiaceae*) is a tree fairly widespread in Southeast Asian countries, known for its medicinal properties. The edible fruit of this plant is considered to be one of the best of all tropical fruits. The fruit hulls have been in use in Thai folk medicine for the treatment of skin infections, wounds, and diarrhea. Xanthenes and its derivatives have been reported to have neuroprotective activity, antiulcer, antioxidant activities, antimalarial, antimicrobial, cytoprotective activity, and anticancer. The authors Priya et al., reported the anticancer potential of *Garcinia mangostana* extract on the hepatocellular carcinoma-induced experimental model through its reduction of growth promoting factor levels and inhibition of cancer marker proteins. In addition, *Garcinia mangostana* extract may have chemopreventive benefits or as a complementary alternative medicine in the treatment of hepatic cancer by reducing the tumor promoting growth factor levels (16)

***Annona muricata***

*Annona muricata* (Family: Annonaceae) is a plant known to have different traditional uses and commonly known as 'Soursop', 'Graviola', 'Guanabana', 'Paw-paw' and 'Sirsakmuricata' were found to have different ethnomedical properties like antimalarial, smooth muscle relaxant, uterine stimulant, anti-crustacean, antiparasitic, cardiac depressant, antiamebic, antibacterial, antifungal and insecticide. *Annona muricata* seeds are reported to be cytotoxic to 6 human cancer cell lines. The leaves of this plant can lower the bilirubin level in jaundice and were reported for hepatoprotective activity. Leaves were also reported for chemopreventive effects in chemically induced mice skin papilloma genesis. The antiulcerogenic property for leaves of *Annona muricata* was also reported in animal models. The edible fruits of this plant were used as a traditional medicine for arthritic pain, neuralgia, diarrhoea, dysentery, fever, malaria, parasites, rheumatism, skin rashes and worms. Seeds of the fruits were used as an insecticide and larvicide for pest control. Plant parts including fruits were reported for anticancer activity because of the presence of acetogenins, which is a new class of anticancer agents. The fruits of *Annona muricata* are mentioned in herbal medicine-books and the authors Thomas et al., explored its anticancer activity using HepG2-cell line and diethylnitrosamine (DEN) induced HCC in rats. *Annona muricata* fruit extract was analyzed to determine the presence of active constituents such as phenolics, flavonoids, tannins, saponins, terpenoids, steroids, glycosides, anthraquinone, lipids, reducing sugar, amino acids, and peptides using appropriate standard methods for each of the constituents determined (17).

***Cynodon dactylon* L**

*Cynodon dactylon* is a perennial grass that has a variety of medicinal properties. Twenty-two compounds were found in *Cynodon dactylon*. Hydroquinone (69.49%), levoglucosone (2.72%), furfural (6.0%), were found to be the most abundant components among the 20 characterized compounds in *Cynodon dactylon*. It is cultivated throughout the tropics and subtropics. Whole herb and its root stalk are practiced for medicinal use. The authors Kowsalya et al., determined the anticancer potential of *Cynodon dactylon* L root extracts using diethyl nitrosamine (DEN)-induced mice model. Their study concludes *Cynodon dactylon* treatment exhibit anti cancerous effect by enhanced activities of antioxidant enzymes (AST, ALT, GST, GPx and CAT). It may be due to the presence of antioxidant property (18).

***Lycopersicon esculentum***

*Lycopersicon esculentum* (*Solanaceae*) being one of the most important "protective foods" due to its special nutritive value is internationally cultivated which is the world's largest vegetable crop after potato. This plant is used in the treatment of several chronic diseases such as cardiovascular diseases and certain types of cancer. Numerous scientific reports validate the uses of *Lycopersicon esculentum* and have shown its significant role in inhibiting oxidation reactions caused by free radicals, thereby prevents or delays damage to cells and tissues. The authors Daset et al., evaluated the efficacy of *Lycopersicon esculentum* on DEN-induced and phenobarbital (PB)-promoted HCC in rats. In



**Anjala Devi et al**

their study, *Lycopersicon esculentum* treated rats showed significant decrease in DNA and RNA level when compared to DEN/PB groups further authenticating the anticancer potential. The inhibitory effects may be due to *Lycopersicon esculentum* containing lycopenes (19).

***Scoparia dulcis***

The *Scoparia dulcis* L aqueous extract prevented DEN induced UTP depletion and a subsequent suppression of nucleic acids by restricting the formation of toxic metabolites from DEN. *Scoparia dulcis* L extract administration decreased lipid peroxides level which may be due to the free radical scavenging activity of the plant extract. *Scoparia dulcis* L protects against LPO by mechanisms that may be dependent on changes in the antioxidant defense system. These observations indicate that, *Scoparia dulcis* L. administration may be protective against DEN induced hepatotoxicity (20).

***Anacardium occidentale***

*Anacardium occidentale* (cashew) is a tree in the family of the flowering plant Anacardiaceae. The family contains 73 genera and about 600 species. *Anacardium* contains eight species, native to tropical America, of which the cashew is by far the most important economically. The leaves and/or the bark is also used in Brazil for eczema, psoriasis, scrofula, dyspepsia, genital problems, and venereal diseases, as well as for impotence, bronchitis, cough, intestinal colic, leishmaniasis, and syphilis-related skin disorders. *Anacardium occidentale* fruit is a rich source of vitamins, minerals, and other essential nutrients. The authors Ikyembeet al., investigated the hepatoprotective activity of pre-treatment with methanolic leaf extract of *Anacardium occidentale* against carbon-tetrachloride (CCl<sub>4</sub>)-induced hepatotoxicity in Wistar rats (21). Leaves extract of *Anacardium occidentale* possess phytoconstituents such as saponins, tannins, and flavonoids, which have been reported to exert antioxidant activities, a strong antioxidant capacity was also observed against hepatocarcinogenesis induced by aflatoxin B1 in Wistar mice.

***Artemisia vulgaris***

*Artemisia vulgaris* belong to family of sesquiterpene trioxane lactone that are used against malaria, derived from the sweet woodworm. In traditional medicine, this plant is being widely used for the treatment of diabetes and the extracts of the whole plant is used for epilepsy and in combination for psychoneurosis, depression, irritability, insomnia and anxiety stress. The authors Aliet al., determined the anticancer potential of *Artemisia vulgaris* extracts using diethyl nitrosamine (DEN)-induced model. After *Artemisia vulgaris* extract administration the levels of biological markers were decreased as compared to DEN treated value and almost equal values to control group showed reduction in the production rate of tumors, this showed that *Artemisia vulgaris* extract scavenged free radicals in the rat liver tissue. After the induction of hepatocellular carcinoma, the extract of *Artemisia vulgaris* caused decrease in values of Alpha-Fetoprotein, Gamma Glutamyl Transpeptidase, 5'-Nucleotidase, Alanine Aminotransferase, Aspartate Transaminase, Lactate Dehydrogenase, Glucose 6-Phosphate Dehydrogenase, total bilirubin levels and increase in levels of albumin and this decrease showed that extract of *Artemisia vulgaris* possess anti-cancerous activity against hepatocellular carcinoma and proven as a potential herb against tumor especially against hepatocellular carcinoma (22).

***Tinospora cordifolia***

*Tinospora cordifolia*, belonging to the family Menispermaceae, is commonly known as Guduchi or Giloe is a large, extensively spreading, glabrous, perennial deciduous shrub widely distributed throughout the plains of India. In Indian Ayurvedic system of medicine, the powder and aqueous extract of the plant is used in debility, hepatitis, dyspepsia, jaundice and other liver afflictions. Its antidiabetic, anti-inflammatory and diuretic activities variety of



**Anjala Devi et al**

constituents has been isolated from *Tinospora cordifolia* belonging to different classes such as alkaloids, diterpenoid lactones, glycosides, steroids and sesquiterpenoids. The authors Jayaprakashet *al.*, studied anticancer activity of *Tinospora cordifolia* on DEN induced liver cancer (23).

**CONCLUSION**

This review concluded that, Diethylnitrosamine is a potential chemical to induce hepatocellular carcinoma. And this review is useful for the researchers to study the anticancer activity of new herbal medicines.

**ACKNOWLEDGEMENTS**

The authors thank to our beloved Managing Trustee, Dr. Nalla G. Palaniswami and respected Trustee madam Dr. Thavamani D. Palaniswami, Kovai Medical Center Research and Educational trust, Coimbatore for all the facilities that were provided at the institution.

**REFERENCES**

1. Mittal S, El-Serag HB. Epidemiology of HCC: consider the population. Journal of clinical gastroenterology, 2013;47:2-6.
2. Befeler AS, Di Bisceglie AM. Hepatocellular carcinoma: diagnosis and treatment. Gastroenterology, 2002;122(6):1609-1619.
3. McGlynn KA, London WT. Epidemiology and natural history of hepatocellular carcinoma. Best practice & research Clinical gastroenterology, 2005;19(1):3-23.
4. Bosetti C, Turati F, La Vecchia C. Hepatocellular carcinoma epidemiology. Best practice & research Clinical gastroenterology, 2014;28(5):753-770.
5. McGlynn KA, London WT. The global epidemiology of hepatocellular carcinoma: present and future. Clinics in liver disease, 2011;15(2):223-243.
6. Said AH, Shetty K, Li Y, Blechacz B, Hawk E, Mishra L. Primary Hepatic Cancer. Handbook of Gastrointestinal Cancer, 2012; 12:161-181.
7. Gopalasatheeskumar K, Ariharasivakumar G, Sengottuvel T *et al.* Confirmation of Best Method for Detection of Alpha Amylase Activity of CucumisMeloVarAgrestis (Wild Musk Melon). J Adv Res BioChemPharma, 2019; 2(1): 1-3.
8. Srigopalram S, Jayraaj IA. Effect of Terminaliachebulon DEN induced hepatocellular carcinogenesis in experimental rats. International Journal of Pharmacy and Pharmaceutical Sciences, 2012; 4(2):440-445.
9. Singh D, Singh M, Yadav E, Falls N, Komal U, Dangi DS, Kumar V, Verma A. Amelioration of diethylnitrosamine (DEN)-induced hepatocellular carcinogenesis in animal models via knockdown oxidative stress and proinflammatory markers by Madhucalongifolia embedded silver nanoparticles. RSC advances, 2018;8(13):6940-6953.
10. Dhodi JB, Thanekar DR, Mestry SN, Juvekar AR. Carissa carandas Linn. fruit extract ameliorates gentamicin-induced nephrotoxicity in rats via attenuation of oxidative stress. Journal of Acute Disease, 2015;4(2):135-140.
11. Baliga MS, Baliga BR, Kandathil SM, Bhat HP, Vayalil PK. A review of the chemistry and pharmacology of the date fruits (Phoenix dactylifera L.). Food research international, 2011;44(7):1812-1822.
12. ThirupathiAnandAM, Mohan SC. Ethanolic Extract of Canthiumcoromandelicum Leaves Exhibits Antioxidant, Anti-inflammatory and Apoptotic Activity in DEN-induced Hepatocellular Carcinoma. Research Journal of Phytochemistry, 2017; 11:1-10.





**Anjala Devi et al**

13. Hamza AA, Heeba GH, Elwy HM, Murali C, El-Awady R, Amin A. Molecular characterization of the grape seeds extract's effect against chemically induced liver cancer: in vivo and in vitro analyses. *Scientific reports*, 2018;8(1270):1-16.
14. Veerabhadrapa KV. Anticancer activity of *Sesbaniagrandiflora* extract against diethyl nitrosamine induced hepatic carcinoma. *Journal of Global Trends in Pharmaceutical Sciences*. 2017; 8(3):4278 – 4284
15. Rajendran V, Krishnasamy K. Attenuation of DEN induced hepatocellular carcinoma by a novel synthesis of silver nanoparticles using *Solanumvillosum* (Mill.) leaves. *Journal of advances in biotechnology*, 2016; 6(2):867-881.
16. Priya VV, Jainu M, Mohan SK. Biochemical evidence for the antitumor potential of *Garciniamangostana* Linnondiethyl nitrosamine-induced hepatic carcinoma. *Pharmacognosy magazine*, 2018;14(54):186-190.
17. Thomas SV, Paul J, Shrungheswara AH, Biswas S, Shah AA, Subraya CK, Nayak Y. *Annonamuricata* fruit extract protects against diethylnitrosamine-induced hepatocellular cancer in rats. *Asian Pacific Journal of Tropical Medicine*, 2019;12(6):272-282.
18. Kowsalya R, Kaliaperumal J, Vaishnavi M, Namasivayam E. Anticancer activity of *Cynodondactylon* L. root extract against diethyl nitrosamine induced hepatic carcinoma. *South Asian journal of cancer*, 2015;4(2):83-87.
19. Das BK, Koti BC, Gadad PC. Role of *Lycopersiconesulentum* in diethylnitrosamine-induced and phenobarbital-promoted hepatocellular carcinoma. *Indian Journal of Health Sciences and Biomedical Research (KLEU)*, 2016; 9(2):147-152.
20. Langeswaran K, Jagadeesan AJ, Vijayaprakash S, Balasubramanian MP. Hepatoprotective and Antioxidant activity of *Scopariadulcis* Linn, against N-Nitrosodiethylamine (DEN) induced Hepatotoxicity in experimental Rats. *Int. J. Drug Dev. & Res.*, 2012; 4(1):295- 303.
21. Ikyembe D, Pwavodi C, Agbon AN. Hepatoprotective effect of methanolic leaf extract of *Anacardiumoccidentale* (cashew) on carbon-tetrachloride-induced liver toxicity in wistar rats. *Sub-Saharan African Journal of Medicine*, 2014;1(3):124-131.
22. Ali S, Ejaz M, Dar KK, Nasreen S, Ashraf N et al. Evaluation of chemopreventive and chemotherapeutic effect of *Artemisia vulgaris* extract against diethylnitrosamine induced hepatocellular carcinogenesis in Balb C mice. *Brazilian Journal of Biology*. 2019; 1-8
23. Jayaprakash R, Ramesh V, Sridhar MP, Sasikala C. Antioxidant activity of ethanolic extract of *Tinosporacordifolia* on N-nitrosodiethylamine (diethylnitrosamine) induced liver cancer in male Wister albino rats. *Journal of pharmacy & bioallied sciences*, 2015;7(1):40-45.





## Studies on Analysis of Bone Calcium Content in Fresh Water and Marine Water Fishes

Lopamudra Samantaray and Yashaswi Nayak\*

Department of Zoology, School of Applied Sciences, Centurion University of Technology and Management, Odisha, India.

Received: 21 Jan 2020

Revised: 23 Feb 2020

Accepted: 25 Mar 2020

### \*Address for Correspondence

#### Yashaswi Nayak

Department of Zoology,  
School of Applied Sciences,  
Centurion University of Technology and Management,  
Odisha, India.

Email: yashaswi.nayak@cutm.ac.in



This is an Open Access Journal / article distributed under the terms of the **Creative Commons Attribution License** (CC BY-NC-ND 3.0) which permits unrestricted use, distribution, and reproduction in any medium, provided the original work is properly cited. All rights reserved.

### ABSTRACT

Fish is a most commonly used and an important dietary source of micronutrients which plays important role in human being nutrition. This work investigates the calcium content of twelve samples of locally available and commonly consumed fishes (includes thirteen freshwater fishes and six marine water fishes) which are collected from local market of Dhenkanal, Odisha, India. The samples were analysed using the method of EDTA titration. The highest calcium content was obtained in Pool barb (*Puntius sophore*) and lowest in Indian Oil Sardine (*Sardinella longiceps*). These outcome results were compared with values reported in the literature. Results demonstrated that extracted fish bone powder was nutritious and can contribute significantly to human health requirements. The expected output of this research will help to effectively utilize the fish bone processing waste as a cheap calcium provider for commercially calcium fortified foods and also reduce environmental pollution. The information on calcium profile of fish will give a guideline to dieticians, nutritionists, medical practitioners, researchers to advice consumers to take fish calcium fortified food in their daily diet as a health food.

**Key words:** Calcium, marine water fish, fresh water fish, bone powder, health benefit, nutrition.

### INTRODUCTION

Calcium is one of the essential mineral component of skeletal system which make up about 1-2% of body weight of an adult human being [1] and helps in development and maintenance of strong bones and teeth, also contributes in biological processes like mitosis, blood coagulation, cell adhesiveness, muscle contraction and also effective in functioning of heart and nerves and for managing acid/base balance in blood stream [2]. Calcium act as a mediator of



**Lopamudra Samantaray and Yashaswi Nayak**

biological processes like muscle contraction secretion, glycolysis, gluconeogenesis, cell division, transportation of ion, cellular growth [3]. India is bestowed with multiple freshwater and marine fish resources. For lactose intolerance population calcium-fortified products would be a good alternate [4]. But utilization of natural calcium sources like freshwater and marine fish bone can be acceptable more by consumers and effects more because of existence of calcium phosphate compound in it [5].

Many countries discarded the huge quantities of fish waste and the by-products of fishes is into the environment and converted into source of terrestrial pollution. In past some years, fish bone of freshwater and marine water fishes was used as feed ingredient in diets for human, [6] which give a positive effect on calcium deficiency and growth inhibition compared to traditional diets [7]. Fish meal which are obtaining from whole fish or by products of freshwater and marine water contains near about 10% minerals that is high in calcium and phosphorus, and also provide a significant source of minerals and macro and micronutrients as included in feed [8]. An edible portion of 150 g of freshwater or marine water fish can provide about 50-60% of an adult's daily calcium content requirement which may help in preventing cardiovascular and other diseases [9].

The organic component of freshwater or marine water fish bone that may accounts for 30% of the material, are made up of collagen [10]. Fish bone may consists of 60%–70% of inorganic substances which are mainly comprised of calcium phosphate [11]. Fish bone fortification into the main food diet is effectively accepted as it is a cheaper way for providing the daily need for a range of vitamins and minerals that is mainly calcium [12]. An inadequate intake of dietary calcium causes bone growth retardation. Bone Growth retardation is highly prevalent in many countries and is associated calcium deficiency with several adverse health effects like osteoporosis, hypocalcaemia throughout the lifetime which gained attention more recently [13]. In women, once estrogen levels decline due to either amenorrhea or menopause, bone-resorption overtakes bone-formation. At this point osteoporosis can begin [14]. Long term inadequate calcium intake along with inadequate weight-bearing exercise are risk factors for developing osteoporosis. In osteoporosis, bone is less dense and therefore more susceptible to fracture. An Association between inadequate calcium intake and overweight in young children as well as obesity in adults was seen [15].

Hypercalcaemia caused mainly by Primary hyperparathyroidism and Malignancy [16]. pHPT patients came problems such as kidney stones, massive bone decalcification with many fractures and severe muscle weakness. pHPT patients have an increased risk of cancer [17]. Hypercalcaemia due to malignancy may arise from local osteolysis releasing calcium bound in the bones. This is often caused by metastases, for instance, from breast, bladder, lung and kidney cancer, as well as myeloma, leukaemia, and lymphoma [16]. Low level of calcium in blood is known as Hypocalcaemia [18]. Causes of low calcium concentrations might be kidney and intestinal disease or malignancies lead to low albumin concentrations [17].

The objective of the present investigation is to examine the availability of calcium in fish bones that can be used as food supplements (calcium fortified foods) that plays an important role in to meet the calcium requirements of consumers. The analysis of calcium of different locally available indigenous fishes will help the scientists, dieticians, physicians, food manufacturers to take decision on production and value addition of fish food products and also can help many consumer for guidance and preference motive. In this study there is an attempt has been made so as to check the bioavailability of calcium in the different low value freshwater and marine water fish bones which can provide daily calcium content need of people in cheaper way.

**MATERIALS AND MATHODS**

All samples were purchased in the open market in Dhenkanal, Odisha, India. They represent fishes as bought by the ordinary consumer. Most of them are, however, not truly native, but were imported Samples. Twelve different staple fishes were collected from local open market and retail stores of Dhenkanal, Odisha, India. One of the





### Lopamudra Samantaray and Yashaswi Nayak

centrally located districts of Odisha, India is Dhenkanal with a total geographical area of 4452 sq.km and situated between north latitude 20° 29'00" and 21° 11'00" and east longitude 85° 58'00" and 86° 02'00". The samples were experimented at Dhenkanal Autonomous College, Dhenkanal.

The collected samples immediately being labelled with clean polythene bags through which contamination could be avoided during the transportation to the laboratory. The samples were stored in refrigerator in the laboratory at 4°C. These samples were analysed within less than 20 days from the time of collection from local market at Dhenkanal Autonomous College Laboratory. Nineteen different fish were washed and boiled separately in distilled water for 30 minutes (min). The flesh attached to fish was cleaned manually from fish bone and washed with water. Then they were dried in the oven at 90 °C for 1 hour by the method of Amitha et al. 2019 [19]. Then samples were kept under direct sunlight for about 15 days. The sample bones were then powdered into finer particles by using a pestle and mortar at laboratory. The sample fish bone powder was kept in container at room temperature. The calcium content was determined. The samples were estimated for calcium content by using standard procedures reported by Lawani et al., 2014[1]

All the sample bone powder was digested by a mixture of concentrated Nitric acid along with Sulphuric acid and Hydrogen peroxide. Five grams of each sample bone powder were put in heat-resistant conical flask. 8ml of concentrated sulphuric acid along with 10ml of nitric acid was added to that flask containing food stuff. Beaker was placed in hot plate and being warmed cautiously until reaction subsided. The flask was heated vigorously until the solution began to darken or charring or partially burnt. Charring of the solution was avoided by constant adding of 2cm<sup>3</sup> aliquot of concentrated nitric acid that was at any time the solution began to darken. This was continued until the solution stopped darkening on prolonged heating. At this point, the solution was allowed to cool down and being diluted with 10ml of distilled water and boiled to fuming. This solution and boiling was repeated twice again with 5cm<sup>3</sup> of distilled water. The persistent colour of solution was cleared by addition of 2ml of hydrogen peroxide with drops of nitric acid again.

The solution was heated to fuming state each time hydrogen peroxide was added until there was no further reduction of pale yellow colour was obtained. The solution was cooled with about 10ml of distilled water and evaporated to fuming once again. This was continued until there was no more fuming, then the solution was made up to mark in 100ml volumetric flask and kept in the conical flask. A 50ml of small aliquot of each digested sample bone powder was pipetted into conical flask. 1M NaOH was added to adjust the pH to 12. Four drops of Solochrome Dark Blue were then added and immediately titrated against a 0.01M EDTA solution to the end blue point. To determine the calcium content of staple fish bone powder, 3 titrations were performed for each fish bone powder.

Calculation for calcium content of Rohu (*Labeo rohita*):

- i) Calculation for average titre of EDTA:  
Average titre of rohu =  $(1.83+1.87+1.85) \div 3 = 1.85\text{ml} = 1.85 \times 10^{-3} \text{ L}$
- ii) Calculation for EDTA in moles in average litre:  
Moles of EDTA = concentration (mol L<sup>-1</sup>) × volume (L)  
=  $0.010 \times 1.85 \times 10^{-3} \text{ L}$   
=  $(1.85 \times 10^{-5}) \text{ L}$
- iii) Calculation of calcium in moles present in 50ml of sample aliquot  
{Ca<sup>2+</sup> + EDTA → (Ca<sup>2+</sup> - EDTA)}  
Moles of Ca<sup>2+</sup> = moles of EDTA =  $(1.85 \times 10^{-5}) \text{ mol}$





### Lopamudra Samantaray and Yashaswi Nayak

- iv) Calculation of concentration of calcium (molarity) in 50ml of the sample aliquot  
 {Molarity of  $\text{Ca}^{2+}$  = moles  $\div$  volume (L)}  
 $= (1.85 \times 10^{-5}) \div (50 \times 10^{-3})$   
 $= (0.37 \times 10^{-3}) \text{ mol L}^{-1}$
- v) Conversion of  $\text{mol L}^{-1}$  concentration into  $\text{mg L}^{-1}$   
 1 Litre of sample contain  $0.37 \times 10^{-3} \text{ mol L}^{-1}$  moles calcium  
 Mass of calcium = moles  $\times$  molar mass  
 $= (0.37 \times 10^{-3}) \times 40.08$   
 $= (1.485 \times 10^{-2}) \text{ g}$
- vi) Conversion of mass in gms to mass in mg by multiplying with 1000  
 $= (1.485 \times 10^{-2}) \times 1000 \text{ mg/g}$   
 $= 14.85 \text{ mg/gm}$
- vii) As the calcium concentration is for 5gm of bone powder, so the calcium concentration for 100gm:  $(100/5 = 20)$   
 $= (14.85 \text{ mg/gm}) \times 20$   
 $= 297 \text{ mg/gm}$

## RESULT

The calcium concentration of freshwater fishes were analysed and given in Table 3. Among all freshwater fishes Pool barb (*Puntius sophore*) (1145mg/100gm) observed to contain higher calcium concentration whereas the Freshwater garfish (*Xenotodon cancella*) (98mg/100gm) had low calcium concentration. The calcium concentration of marine water fishes were analysed and given in Table 4. Among all marine fishes Konoshiro gizzard shad (*Konosirus punctatus*) (196mg/100gm) observed to contain higher calcium concentration whereas the Indian oil sardine (*Sardinella longiceps*) (27mg/100gm) had low calcium concentration. Graph 6. Show the contribution of amount of all staple edible fish items. Freshwater fish bone powder contribute more calcium marine water fishes. The total calcium content contributed by freshwater fish bone powder is 2762mg/g. It compared with marine water fish bone calcium content which show that fresh water fish make up 82.10% of total calcium content of all staple fish items. Whereas marine water fish bone powder contribute about 17.89% of calcium content which is 602mg/g.

Graph 4. shows that among fresh water fish bone, Pool barb (*Puntius sophore*) contribute 1145mg/g out of total calcium content, which is about 41% of total fresh water fish bone calcium content. In case of marine water fish bone, Konoshiro gizzard shad (*Konosirus punctatus*) contribute about 33% of total marine water fish bone calcium content. Graph 5. In case of marine water fish bones, Konoshiro gizzard shad and Golden threadfin bream contribute more calcium than others. Flathead grey mullet (*Mugil cephalus*) (47mg/100gm) and Silver pomfret (*Pampus argenteus*) (40mg/100gm) contribute almost equivalent amount of calcium content. Indian oil sardine contribute the lowest calcium content among all fishes.

## DISCUSSION

The present work elucidated on the importance of fresh water and marine water fish bones as rich source of minerals and has broadened our knowledge on the calcium content difference between freshwater and marine fish species. Calcium content of studied fish groups were quite similar with the calcium content reported by Longvah et al., 2017 [20] samples in present study calcium content results. The calcium profile of *Labeo rohita* and *Pampus argenteus* show great difference in calcium content. But fish like *Mugil cephalus*, *Sardinella longiceps*, *Oreochromis mossambicus* show



**Lopamudra Samantaray and Yashaswi Nayak**

quite similarity in calcium content. Among the similar fishes *Sardinella longiceps* show highest calcium content value whereas *Pampus argenteus* show the lowest value. Among all fishes the calcium content of fresh water fish *Labeo rohita* show great variation in the high calcium content in percentage than Longvah et al., 2017 [20].

Bogard et al., 2015 [11] studied on nutrient composition of some important fish species in Bangladesh. The reported value of *Notopterus* by Bogard et al., 2015 [11], was almost similar to the calcium content of this experiment, which means it is just 7% difference between these two content values. The calcium content of *Puntius sophore*, *Oreochromis mossambicus*, *Anabas testudines* and *Pampus argenteus* of this local work show rise under 30% in comparison to their work. From freshwater fish category, *Channa striata*, *Labeo rohita* and *Xenectodon cancila* show great difference with 811%, 482% and 84% respectively.

In Table 5., Zaman et al., 2014<sup>[6]</sup> reported mean calcium content in fish samples like *Labeo rohita*, *Puntius sophore*, *Pampus argenteus* and *Oreochromis mossambicus*. Their work show less variation in freshwater fish like *Labeo rohita* and *Puntius sophore* with difference of 2% and 17% respectively. Their work evaluates calcium content of *Pampus argenteus* and *Oreochromis mossambicus* which was evaluated 93% and 78% higher than our result. Hossain et al., 1999[21] and this respective work show only two similar food items like *Puntius sophore* and *Xenectodon cancila* in comparison this investigation had 4 percent and 389 percent more calcium content. Mohanty et al. 2016 [8], investigated the micronutrient composition of thirty-five staple fish items of their locality and commonly consumed food items which was collected from India by AAS. Their work shows large variation in calcium content of *Xenectodon cancila*, *Labeo rohita*, *Mugil cephalus* and *Sardinella longiceps* (Table 5.) whereas it was contrasted with 98%, 45%, 82% and 95% than our value of calcium.

The difference in calcium content of this respective study might have been attributed by different factors. The change could have been caused by anomalies of measurement of sampling, changes in laboratory practices or changes in varieties collected. Sample collection conditions including fertilizer application and storage and marketing conditions also influence mineral contents of fishes. The fish state of maturation, genetic variance and environmental factors were also the possible for the differences observed. Fish is an important source of calcium, and in comparison to the other dietary sources of calcium, the consumers have a wide choice for fish, as there are wide varieties and species of marine water and fresh water fishes available, especially in India. Calcium content of nineteen Indigenous fish from Dhenkanal, Odisha, India were determined and compared with some reported work. Among freshwater fishes Pool barb (*Puntius sophore*) show highest calcium content in between all fishes whereas Konosiro gizzard shad (*Konosirus punctatus*). This data represented in this study shown that freshwater fish bones have higher content of calcium than marine water fish bones. This mineral information would increase the utility of these fish bones. The paper describes the successful linking of human nutrition with fish Dhenkanal.

**Future scope**

Although fish bone calcium content play important role in maintaining skeletal health, although available locally and commonly. Alternative warm area of this research relates to the use fish bone calcium in consumed foods and treatment of osteoporosis, osteomalacia and low bone mineral density.

**ACKNOWLEDGEMENTS**

The authors gracefully acknowledge for providing necessary help and support provided by Centurion University of Technology and Management. The author wish to thank Dr.Yashaswi Nayak and Dr.Siba Prasad Parida (HoD) for providing necessary facility to conduct the work.



**Lopamudra Samantaray and Yashaswi Nayak****Conflict of interest**

We declare that this work have no conflict of interest.

**REFERENCES**

1. Lawani Samuel Adetunji, GiwaAbdurrahin Adebisi, Bello Isah Adewale and Okwonkwo Erasmus O.. Titrimetric Determination of Calcium Content of Some Staple Foodstuffs in North-Central Nigeria. *Food Science and Quality Management* [Online] 2014; 24: 50-57. Available: <https://www.researchgate.net/publication/273380593>
2. Beto Judith A.. The Role of Calcium in Human Aging. *Clin Nutr Res* [Online] 2015;4: 1-8. Available: <http://dx.doi.org/10.7762/cnr.2015.4.1.1>
3. ForsenSture and Kordel Johan. Calcium in Biological Systems. *SemanticScholar* [Online] 2007; 107-166. Available: <https://www.semanticscholar.org/paper/Calcium-in-Biological-Systems-STURE-FORSEN-AND-Kordel/9d1689d5988555125c549913017081694299e3cb>
4. Roos Nanna, Wahab Md. Abdul, Hossain Mostafa Ali Reza, and Thilsted Shakuntala Haraksingh. Linking human nutrition and fisheries: Incorporating micronutrient-dense, small indigenous fish species in carp polyculture production in Bangladesh. *Food and Nutrition Bulletin* [Online] 2007; 28: 280-293. Available: <https://www.ncbi.nlm.nih.gov/pubmed/17658074>
5. Paul B.N., Chanda S., Sridhar N., Saha G.S. and Giri S.S.. Proximate, Mineral and Vitamin Contents of Indian Major Carp. *Indian J. Anim. Nutr* [Online] 2016; 33 (1): 102-107. Available: doi: 10.5958/2231-6744.2016.00018.9
6. Zaman Maria, Naser M. Niamul, Abdullah Abu Tareq Mohammad and Khan Nasima. Nutrient contents of some popular freshwater and marine fish species of Bangladesh. *Bangladesh J. Zool.* [Online] 2014; 42(2): 251-259. Available: <https://www.banglajol.info/index.php/BJZ/article/view/23367>
7. Mohanty B.P., Pati M.K., Bhattacharjee S., Hajra A. and Sharma A.P.. Small indigenous fishes and their Importance in human health. *Advances in Fish Research* [Online] 2013; V: Pages 257–278. Available: [https://www.researchgate.net/publication/283318690\\_SMALL\\_INDIGENOUS\\_FISHES\\_AND\\_THEIR\\_IMPORTANCE\\_IN\\_HUMAN\\_HEALTH](https://www.researchgate.net/publication/283318690_SMALL_INDIGENOUS_FISHES_AND_THEIR_IMPORTANCE_IN_HUMAN_HEALTH)
8. Mohanty Bimal P. & Sankar T. V. &GangulySatabdi&MahantyArabinda&Anandan R. & Chakraborty Kajal & Paul B. N. &SarmaDebajit&Dayal J. Syama& Mathew Suseela& K. K. Asha & Mitra Tandrima& Karunakaran D. & Chanda Soumen& Shahi Neetu & Das Puspita& Das Partha& Akhtar Md Shahbaz &Vijayagopal P. & Sridhar N.. Micronutrient Composition of 35 Food Fishes from India and Their Significance in Human Nutrition. *Biological Trace Element Research* [Online] 2016. Available: <https://www.researchgate.net/publication/301732151>
9. GhuzailiSumaiya Al , Jesil Anna & Saravanan, A. M. Extraction of Calcium Phosphate from Animal Bones. *International Journal of Engineering Research & Technology (IJERT)* [Online] 2019; 8(1): 136-138. Available on: <https://www.ijert.org/extraction-of-calcium-phosphate-from-animal-bones>
10. Jung Won-Kyo, Shahidi Fereidoon, and Kim Se-Kwon. Calcium from Fish Bone and Other Marine Resources. *Marine Nutraceuticals and Functional Foods* [Online] 2007; 419-429. Available: <https://www.researchgate.net/deref/http%3A%2F%2Fdx.doi.org%2F10.1201%2F9781420015812.ch17>
11. Bogard Jessica R., Thilsted Shakuntala H., Marks Geoffrey C., Wahab Md. Abdul, Hossain Mostafa A.R., Jakobson Jette, Satangoulis James. Nutrient composition of important fish species in Bangladesh and potential contribution to recommended nutrient intakes. *Journal of Food Composition and Analysis* [Online] 2015; 42: 120–133. Available: <http://dx.doi.org/10.1016/j.jfca.2015.03.002>
12. Nemati Mahnaz, Huda, N. and Ariffin, F. Development of calcium supplement from fish bone wastes of yellowfin tuna (*Thunnusalbacares*) and characterization of nutritional quality. *International Food Research Journal* [Online] 2017; 24(6): 2419-2426. Available: <https://www.researchgate.net/publication/322446977>
13. Mukundan M. K., Radhakrishnan A. G., James M. A. and Nair M. R.. Comparative Study of the Nutrient Content of Fish and Shell Fish. *Fish. Technol* [Online] 1981; 118: 129-132. Available: <https://core.ac.uk/download/pdf/33721533.pdf>





### Lopamudra Samantaray and Yashaswi Nayak

14. Prentice A. Diet, nutrition and the prevention of osteoporosis. *Public Health Nutrition* [Online] 2004; 7(1A): 227–243. Available from: DOI: 10.1079/PHN2003590.
15. Bani-issaWegdan, Eldeirawi Kamal, HarfilSondos, and FakhryRanda. Vitamin D Deficiency and Its Determinants in Adults: A Sample from Community-Based Settings in the United Arab Emirates. *Hindawi International Journal of Endocrinology* [Online] 2017; 2017, 1-7. Available: <https://doi.org/10.1155/2017/3906306>
16. Turner Jeremy J O. Hypercalcaemia – presentation and management. *Clinical Medicine* [Online] 2017; 17(3): 270–273. Available: <https://www.ncbi.nlm.nih.gov/pmc/articles/PMC6297576/>
17. PravinaPiste, SayajiDidwagh and AvinashMokashi. Calcium and its Role in Human Body. *International Journal of Research in Pharmaceutical and Biomedical Sciences* [Online] 2012; 4(2): 659-668. Available: [https://www.researchgate.net/publication/274708965\\_Calcium\\_and\\_its\\_Role\\_in\\_Human\\_Body](https://www.researchgate.net/publication/274708965_Calcium_and_its_Role_in_Human_Body)
18. Patricia A. Schenck, Dennis J. Chew, Larry Allen Nagode, and Thomas J. Rosol. Disorders of calcium: Hypercalcemia and hypocalcemia. *ResearchGate* [Online] 2006; 122-193. Available: [https://www.researchgate.net/publication/285432462\\_Disorders\\_of\\_Calcium\\_Hypercalcemia\\_and\\_Hypocalcemia](https://www.researchgate.net/publication/285432462_Disorders_of_Calcium_Hypercalcemia_and_Hypocalcemia)
19. Amitha, C.V. Raju, I.P. Lakshmisha, P. Arun Kumar, A. Sarojini, Gajendra and Jag Pal. Nutritional Composition of Fish Bone Powder Extracted from Three different Fish Filleting Waste Boiling with Water and an Alkaline Media. *International Journal of Current Microbiology and Applied Sciences* [Online] 2019; 8(2): 2942-2948. Available: <https://doi.org/10.20546/ijcmas.2019.802.342>
20. Longvah T., Ananthan R., Bhaskarachary K., Venkaiah K.. *Indian Food Composition Tables 2017*. [Online] Telangana, India: National Institute of Nutrition; 2017. Available: <http://www.indiaenvironmentportal.org.in/files/file/IFCT%202017%20Book.pdf>
21. Hossain M.A. and Yoshimatsu T.. Dietary calcium requirements in fishes. *Aquaculture Nutrition* [Online] 2014; 20: 1-11. Available: DOI: 10.1111/anu.12135

**Table 1. Titration for Rohu**

No. of titrations	VOLUME OF EDTA(ML)
1	1.87ml
2	1.85ml
3	1.83ml

**Table 2. Selected staple fishes analysed for calcium content with their scientific name**

serial number	local name (odia)	common name	scientific name
<b>Freshwater Fishes</b>			
1.	Rohi	Rohu (South Asia)	<i>Labeorohita</i>
2.	Gadisha	Sneakheadmurrel (Southeast Asia)	<i>Channa striata</i>
3.	Gania	Freshwater garfish	<i>Xenentodon cancila</i>
4.	Kerandi	Pool barb (India, Bangladesh, Nepal, Bhutan, China)	<i>Puntius sophore</i>
5.	Kau	Climbing perch (Asia)	<i>Anabas testudineus</i>
6.	Fali	Bronze featherback (Southeast Asia)	<i>Notopterus</i>
<b>Marine Water Fishes</b>			
1.	Pamplet	Silver pomfret (Middle East, South Asia)	<i>Pampus argenteus</i>
2.	Balangi	Konoshiro gizzard shad (Asian coastline)	<i>Konosirus punctatus</i>







**Lopamudra Samantaray and Yashaswi Nayak**

3.	Baisiali	Flathead grey mullet (Worldwide)	<i>Mugil cephalus</i>
4.	Kaukokali	Indian oil sardine (Northern region of Indian Ocean)	<i>Sardinella longiceps</i>
5.	Patharamundi	Golden threadfin bream (Western Pacific, JAPAN)	<i>Nemipterusvirgatus</i>
6.	Kalabainshi	Tilapia (Worldwide)	<i>Oreochromis mossambicus</i>

**Table 3. Calcium content (mg/100g) of Fresh water fishes**

Sl. No.	Food Stuff	Calcium content (mg/100g)
1.	Rohu ( <i>Labeorohita</i> )	297
2.	Sneakheadmurrel( <i>Channastrinata</i> )	875
3.	Freshwater garfish ( <i>Xenetodoncancila</i> )	98
4.	Pool barb ( <i>Puntius sophore</i> )	1145
5.	Climbing perch ( <i>Anabas testudineus</i> )	105
6.	Bronze featherback ( <i>Notopterusnotopterus</i> )	245

**Table 4. Calcium content (mg/100g) of Marine water Fishes**

SL. No.	Food Stuff	Calcium content (mg/100g)
1.	Silver pomfret ( <i>Pampus argenteus</i> )	40
2.	Konoshiro gizzard shad ( <i>Konosirus punctatus</i> )	196
3.	Flathead grey mullet ( <i>Mugil cephalus</i> )	47
4.	Indian oil sardine ( <i>Sardinella longiceps</i> )	27
5.	Golden threadfin bream ( <i>Nemipterusvirgatus</i> )	175
6.	Tilapia ( <i>Oreochromis mossambicus</i> )	117

**Table 5. Calcium content (mg/100g) of fishes in this study compared with some reported values**

SI no.	Food stuff	Calcium content of foods (mg/100g)						Percent (%) value of Calcium				
		This work (S)	A*	B*	C*	D*	E*	S/A*	S/B*	S/C*	S/D*	S/E*
<b>Fresh Water Fishes</b>												
1	<i>Labeorohita</i>	297	39.36	51	291	-	205	654↑	482↑	2↑	-	45↑
2	<i>Channastrinata</i>	875	-	96	-	-	-	-	811↑	-	-	-
3	<i>Xenetodoncancila</i>	98	-	610	-	94	5310	-	84↓	-	4↑	98↓
4	<i>Puntius sophore</i>	1145	-	1042	977.96	234	944	-	10↑	17↑	389↑	21↑
5	<i>Anabas testudineus</i>	105	-	85	-	-	252	-	24↑	-	-	58↓
6	<i>Notopterus</i>	245	-	230	-	-	-	-	7↑	-	-	-
<b>Marine water fishes</b>												
7	<i>Pampus argenteus</i>	40	13.64	31	574	-	-	194↑	29↑	93↓	-	-
8	<i>Konosirus punctatus</i>	196	-	-	-	-	-	-	-	-	-	-
9	<i>Mugil cephalus</i>	47	35.20	-	-	-	263	16↑	-	-	-	82↓
10	<i>Sardinella longiceps</i>	27	42.26	-	-	-	523	36↓	-	-	-	95↓
11	<i>Nemipterusvirgatus</i>	175	-	-	-	-	-	-	-	-	-	-
12	<i>Oreochromis mossambicus</i>	117	99.39	95	528	-	-	18↑	23↑	78↓	-	-

Reported value by A):Longvah et al.[20], 2017 B):Bogard et al.[11], 2015 C):Zaman et al.[6], 2014, D): Hossain et al.[21], 1999 E):Mohanty et al. 2016[8] S): This work \*\* Increased/ Decreased = Studied value - Reported value / Reported value X 100 (↑ denoted for increased, ↓ denoted for decreased)





Lopamudra Samantaray and Yashaswi Nayak

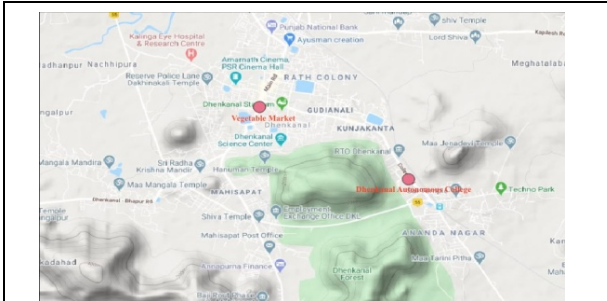

Figure 1 - Showing Dhenkanal Market and Dhenkanal Autonomous College



Figure.2 . Rohu (*Labeo rohita*)



Figure. 3. Sneakheadmurrel (*Channa striata*)



Figure. 4. Freshwater garfish (*Xenotodon cancila*)



Figure. 5. Pool barb (*Puntius sophore*)



Figure. 6. Climbing perch (*Anabas testudineus*)



Figure. 7. Bronze featherback (*Notopterus notopterus*)



Figure. 8. Silver pomfret (*Pampus argenteus*)



Figure. 9. Konoshiro gizzard shad (*Konosirus punctatus*)



Figure. 10. Flathead grey mullet (*Mugil cephalus*)





Lopamudra Samantaray and Yashaswi Nayak



Figure. 11. Indian oil sardine (*Sardinella longiceps*)



Figure. 12. Golden threadfin bream (*Nemipterus virgatus*)



Figure. 13. Tilapia (*Oreochromis mossambicus*)



Figure. 14. Bone powder of Rohu



Figure. 15. Bone of Silver pomfret (*Pampus argenteus*)



Figure. 16. Bone of Pool barb (*Puntius sophore*)

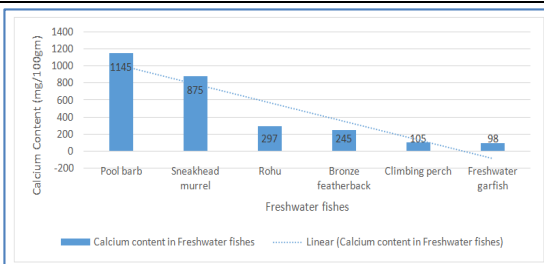

Graph 1. Calcium content in Freshwater fishes

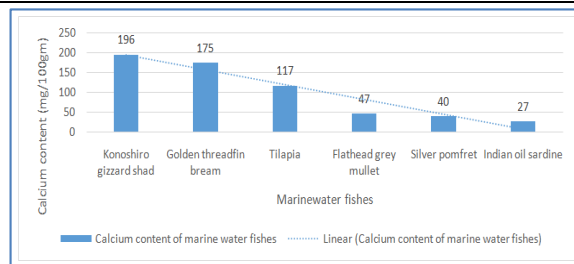

Graph 2. Calcium content of marine water fishes

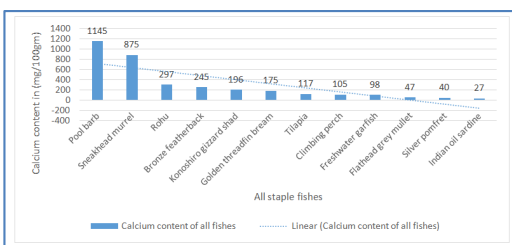

Graph 3. Calcium content of all fishes

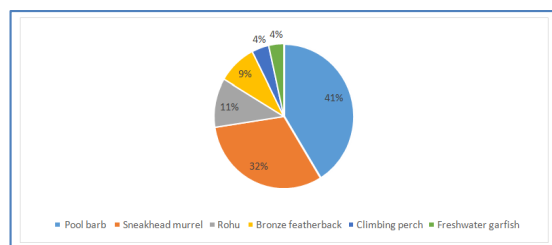

Graph 4. Contribution of Freshwater fishes on Total Freshwater Fish Calcium Content





**Lopamudra Samantaray and Yashaswi Nayak**

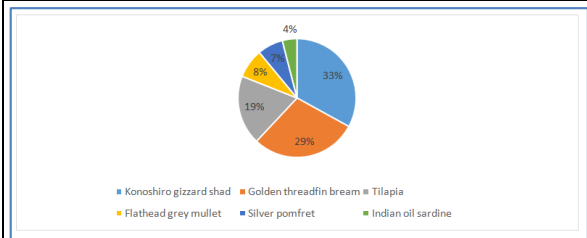

**Graph 5. Contribution of Marinewater fishes on Total Marinewater Fish Calcium Content**

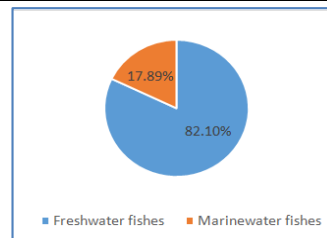

**Graph 6. Contribution of all staple fishes on Total Calcium Content Collected images**





## ***In silico* Molecular Docking-Based Screening of Phytochemicals Targeted against Glypican-1**

Gagan Kumar Panigrahi, Shraban Kumar Sahoo and Kunja Bihari Satapathy\*

School of Applied Sciences, Centurion University of Technology and Management, Odisha, India.

Received: 20 Jan 2020

Revised: 22 Feb 2020

Accepted: 25 Mar 2020

### \*Address for Correspondence

**Kunja Bihari Satapathy**

School of Applied Sciences,  
Centurion University of Technology and Management,  
Odisha, India.

Email: kunjabihari.satapathy@cutm.ac.in



This is an Open Access Journal / article distributed under the terms of the **Creative Commons Attribution License** (CC BY-NC-ND 3.0) which permits unrestricted use, distribution, and reproduction in any medium, provided the original work is properly cited. All rights reserved.

### ABSTRACT

Heparan sulphate proteoglycans (HSPGs) includes Glypicans, primarily involved in critical cellular pathways. Essentially, these groups of proteins are located on the cell membrane and modulate signalling pathways resulting in the cell growth process. Strikingly, the protein level of Glypican-1 (GPC-1) rises primarily during pancreatic cancer, thus acting as a potential clinical biomarker. Further, GPC-1 may also activate further downstream events, supporting the cancerous phase. To restrict the activity of GPC-1, several bio molecules can be deployed, of which the phytochemicals can be the best alternative. Molecular docking-based screening of a few phytochemicals revealed that the organosulfide class of phytochemicals effectively associate with the active site of the GPC-1 and hence bears diagnostic and therapeutic potentials against pancreatic cancer.

**Keywords:** Heparan sulphate proteoglycan, glypican-1, pancreatic cancer, biomarker, phytochemicals, organosulfides.

### INTRODUCTION

Cancer still being considered as a global health problem owing to failure in restricting the casualty it causes [1]. Though the key oncogenic signaling mechanisms are revealed as of now [2, 3], being intracellular in nature, making them inaccessible antibody targets. HSPGs reside at the cell surface and in the extracellular matrix (ECM) are essentially the proteins of interest [4, 5, 6]. Glypicans belong to the HSPG family. Mostly, glypicans are involved in enhancing the extracellular growth, enabling overgrowth of human cells ultimately leading to cancer [7]. Even, glypicans are highly expressed in few cancers, regulate angiogenesis thus facilitate the tumourigenesis as apparent from several genetic evidences [8, 9, 10]. GPC-1 is highly expressed in cancerous cells [11, 12, 13, 14, 15] and found in the peripheral blood, thus can be a key biomarker [5, 16]. GPC-1 knockdown inhibits the response of mitosis to



**Gagan Kumar Panigrahi et al.**

fibroblast growth factor-2, thus pointing out the molecular mechanism of GPC-1 in promoting cancer [12]. GPC-1 also plays a significant role in modulating the VEGF-A and TGF- $\beta$  signalling pathways [17, 18, 19]. Owing to the cleavable nature of the GPC-1 and a secreted soluble component, it is noticeable in the peripheral blood, thus acting as a potential marker [20]. In order to develop a prospective diagnostic tool or therapeutic agent against GPC-1, several approaches can be considered. Using phytochemicals can also be one of the best alternatives. Several categories of phytochemicals are found in the plant parts like fruit, leaf, stem, root, flower and bark which contain immense pharmaceutical functionalities [21]. For treating diseases like cancer, phytochemical compounds like tocopherols, carotenoids, anthocyanins, phenolics etc. are effective [22, 23]. Several phytochemicals act as natural antioxidants, which supplements the need of the human body [24]. Across the globe, it is recommended for consumption of fruits and vegetables, primarily to improve the state of health [25]. We primarily screened a few phytochemicals, which are not yet globally recognized for being used against GPC-1, using a molecular docking method (BIOVIA).

## METHODS

### Viral Protein Structure and Phytochemicals dataset collection

From the Protein Data Bank (accession: 4AD7), the 3D structure of Glypican-1 protein was accessed. For docking with the target protein, Glypican-1, ten numbers of phytochemicals were considered and SDF file accession numbers were used for the purpose.

### Molecular docking

In silico molecular docking was done by using the BIOVIA's Discovery Studio docking method (CDOCKER; Dassault Systèmes BIOVIA, 2020). The catalytic pocket of the GPC-1 protein was generated and subsequently targeted for ligand interaction.

## RESULTS AND DISCUSSION

The positive values of the CDOCKER Energy and CDOCKER\_INTERACTION\_ENERGY represent the affinity of the ligands with the receptor proteins. Ten numbers of phytochemicals (Table 1) against the GPC-1 protein, revealed that phenyl isothiocyanate, benzyl isothiocyanate and resveratrol are potential binding ligands as evident from their higher CDOCKER ENERGY and CDOCKER\_INTERACTION\_ENERGY (Table 1 and Fig. 1). These are very common and easily available. Phytochemicals including Hesperidin, Epicatechin, Tangeretin, Allicin, Sulforaphane, Cyanidin and Malvidin didnot show affinity for the active site of the GPC-1 as the docking results were failed. The chemical structure of ligand molecules (Fig. 2) showing positive affinity for the GPC-1 can be studied extensively and related synthetic molecules can be developed for wide range applications in the cancer therapeutics.

### Conclusion and Future perspectives

*In silico* molecular docking based study reveals several novel candidate molecules which can target the Glypican-1 protein. It would be highly significant being confirmed *in vivo*. Specific phytochemical targeting GPC-1 can be employed in two ways. Firstly, these phytomolecules may act as drug by blocking the specific sites of GPC-1, ultimately inhibiting the downstream pathways. Secondly, cost effective medical device can be developed to diagnose early stages of cancer by targeting marker proteins like GPC-1. Phytochemicals including phenyl isothiocyanate, benzyl isothiocyanate, resveratrol may be effective. Since, glypicans are highly significant in modulating the growth factor signaling and promote cancerous activity; they should be restricted being over



**Gagan Kumar Panigrahi et al.**

activated by blocking their active site (Fig. 3). Early diagnosis being a critical issue in several cancers, appropriate ligands can be developed to be used as a diagnostic tool.

**Author contribution statement**

GKP and KBS conceived the idea. GKP and SKS performed the experiments. GKP, SKS and KBS analyzed the data. All authors contributed significantly in drafting the manuscript.

**Funding**

The present study was financially supported by Centurion University of Technology and Management, Odisha, India.

**ACKNOWLEDGEMENTS**

Authors are thankful to the administration and management of Centurion University of Technology and Management, Odisha, India for providing necessary facilities to conduct the experiment.

**Conflict of interest**

The authors declare that they have no conflict of interest.

**REFERENCES**

1. Ferlay J, Colombet M, Soerjomataram I, Mathers C, Parkin DM, Pineros M et al. 2019. Estimating the global cancer incidence and mortality in 2018: GLOBOCAN sources and methods. *Int J Cancer*. 144: 1941-1953.
2. BaileyMH, Tokheim C, Porta-Pardo E, Sengupta S, Bertrand D, Weerasinghe A et al. 2018. Comprehensive characterization of cancer driver genes and mutations. *Cell*. 173: 371-85.
3. Sanchez-Vega F, Mina M, Armenia J, Chatila WK, Luna A, La K et al. 2018. Oncogenic signaling pathways in the cancer genome atlas. *Cell*. 173: 321-37.
4. Knelson EH, Nee JC, Blobe GC. 2014. Heparan sulfate signaling in cancer. *Trends Biochem Sci*. 39: 277-88.
5. Nagarajan A, Malvi P, Wajapeyee N. 2018. Heparan sulfate and heparan sulphate proteoglycans in cancer initiation and progression. *Front Endocrinol*. 9: 483.
6. Christianson HC, Svensson KJ, van Kuppevelt TH, Li JP, Belting M. 2013. Cancer cell exosomes depend on cell-surface heparan sulfate proteoglycans for their internalization and functional activity. *Proc Natl Acad Sci USA*. 110: 17380-5.
7. Sarrazin S, Lamanna WC, Esko JD. 2011. Heparan sulfate proteoglycans. *Csh Perspect Biol*. 3a: 4952.
8. Filmus J, Capurro M, Rast J. 2008. Glypicans. *Genome Biol*. 9: 224.
9. Fico A, Maina F, Dono R. 2011. Fine-tuning of cell signaling by glypicans. *Cell Mol Life Sci*. 68: 923-9.
10. Li N, Gao W, Zhang Y, Ho M. 2018. Glypicans as cancer therapeutic targets. *Trends Cancer*. 4: 741-54.
11. Lu H, Niu F, Liu F, Gao J, Sun Y, Zhao X. 2017. Elevated glypican-1 expression is associated with an unfavorable prognosis in pancreatic ductal adenocarcinoma. *Cancer Med*. 6:1181-91.
12. Matsuda K, Maruyama H, Guo F, Kleeff J, Itakura J, Matsumoto Y et al. 2001. Glypican-1 is overexpressed in human breast cancer and modulates the mitogenic effects of multiple heparin-binding growth factors in breast cancer cells. *Cancer Res*. 61: 5562-9.
13. Davies EJ, Blackhall FH, Shanks JH, David G, McGown AT, Swindell R et al. 2004. Distribution and clinical significance of heparan sulphate proteoglycans in ovarian cancer. *Clin Cancer Res*. 10: 5178-86.
14. Suhovskih AV, Mostovich LA, Kunin IS, Boboev MM, Nepomnyashchikh GI, Aidagulova SV et al. 2013. Proteoglycan expression in normal human prostate tissue and prostate cancer. *ISRN Oncol*. 1-9.





## Gagan Kumar Panigrahi et al.

15. Hara H, Takahashi T, Serada S, Fujimoto M, Ohkawara T, Nakatsuka R et al. 2016. Overexpression of glypican-1 implicates poor prognosis and their chemoresistance in oesophageal squamous cell carcinoma. *Brit J Cancer*. 115: 66-75.
16. Lewis JM, Vyas AD, Qiu Y, Messer KS, White R, Heller MJ. 2018. Integrated analysis of exosomal protein biomarkers on alternating current electrokinetic chips enables rapid detection of pancreatic cancer in patient blood. *ACS Nano*. 12: 3311-20.
17. Olsson AK, Dimberg A, Kreuger J, Claesson-Welsh L. 2006. VEGF receptor signalling - in control of vascular function. *Nat Rev Mol Cell Biol*. 7: 359-71.
18. Aikawa T, Whipple CA, Lopez ME, Gunn J, Young A, Lander AD et al. 2018. Glypican-1 modulates the angiogenic and metastatic potential of human and mouse cancer cells. *J Clin Invest*. 118: 89-99.
19. Liu S, Chen S, Zeng J. 2018. TGF beta signaling: a complex role in tumorigenesis (Review). *Mol Med Rep*. 17: 699-704.
20. Wang S, Qiu Y, Bai B, Bai B. 2019. The Expression, Regulation, and Biomarker Potential of Glypican-1 in Cancer. *Frontiers in Onco*. 9: 1-7.
21. Jakubowski W, Bartosz G. 1997. Estimation of oxidative stress in *saccharomyces cerevisiae* with fluorescent probes. *Int. J. Biochem. Cell Biol*. 29: 1297-1301.
22. Altemimi A, Lakhssassi N, Baharlouei A, Watson D G, 2017. Phytochemicals: Extraction, Isolation and Identification of Bioactive Compounds from Plant Extracts. *Plants*. 6: 42.
23. Naczka M, Shahidi F. 2006. Phenolics in cereals, fruits and vegetables: Occurrence, extraction and analysis. *J. Pharm. Biomed. Anal*. 41: 1523-1542.
24. Boots A W, Haenen G R, Bast A. 2008. Health effects of quercetin: From antioxidant to nutraceutical. *Eur. J. Pharmacol*. 585: 325-337.
25. Vivekananthan D P, Penn M S, Sapp S.K, Hsu A, Topol E J. 2003. Use of antioxidant vitamins for the prevention of cardiovascular disease: Meta-analysis of randomised trials. *Lancet*. 361: 2017-2023.

Table 1: List of phytochemicals tested for their binding affinity with the GPC-1.

Class	Ligand		Receptor		Interaction Status		
	SDF accession	Phytochemical	Protein	PDB accession	Docking Result	CDOCKER Energy	CDOCKER Interaction Energy
Flavonoids	CHEBI:28775	Hesperidin	Glypican-1	4AD7	Negative	Not applicable	Not applicable
	CHEBI:23053	Epicatechin			Negative	Not applicable	Not applicable
	CHEBI:9400	Tangeretin			Negative	Not applicable	Not applicable
Organosulfides	CHEBI:85103	Phenyl isothiocyanate			Positive	11.78	14.17
	CHEBI:17484	Benzylisothiocyanate			Positive	15.02	17.41
	CHEBI:28411	Allicin			Negative	Not applicable	Not applicable
	CHEBI:47807	Sulforaphane			Negative	Not applicable	Not applicable
Anthocyanin	CHEBI:71682	Cyanidin			Negative	Not applicable	Not applicable
	CHEBI:6674	Malvidin			Negative	Not applicable	Not applicable
Stylbenes	CHEBI:45713	Resveratrol			Positive	21.23	33.55







Gagan Kumar Panigrahi et al.

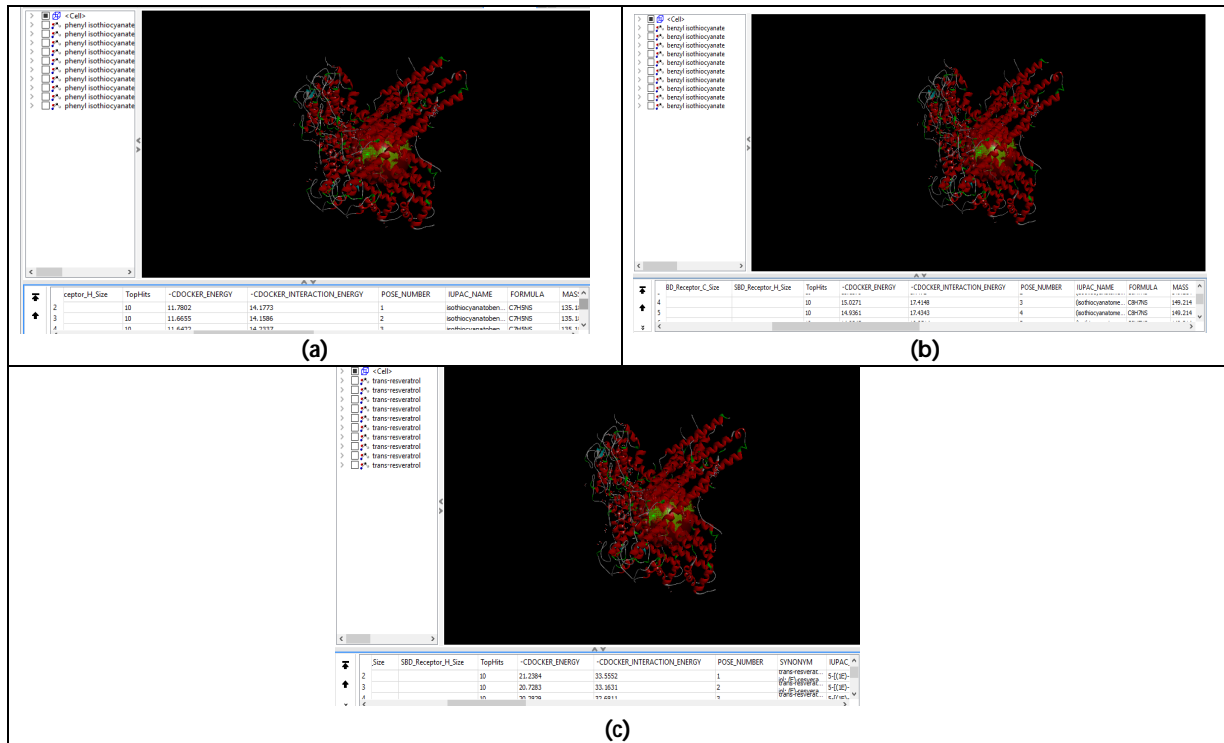

Fig. 1: The active site of the GPC-1 associates with (a) Phenyl isothiocyanate (b) Benzyl isothiocyanate (c) Resveratrol.

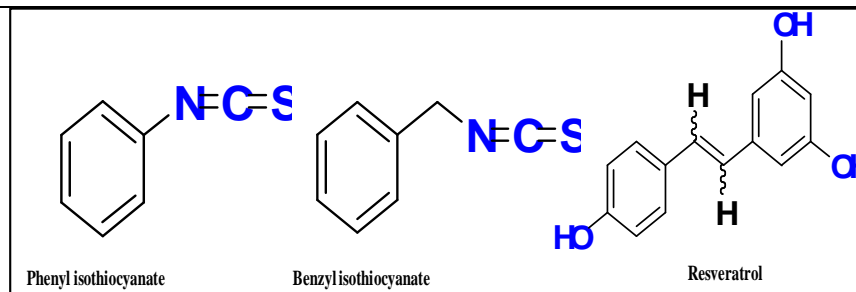

Fig. 2: Chemical structure of the Phenyl isothiocyanate, Benzyl isothiocyanate and Resveratrol.

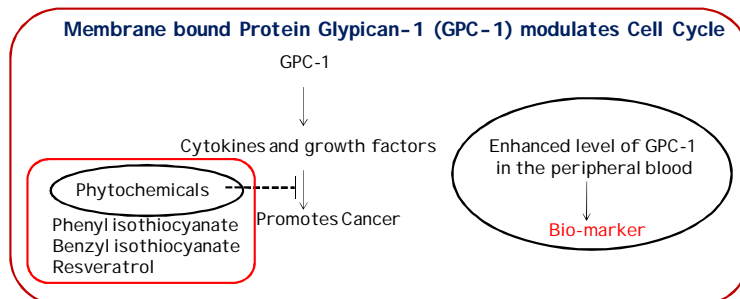

Fig. 3: Phytochemicals can be effectively used for blocking the activity of the GPC-1





## ***In vitro* Cell Line Techniques for the Biological Screening of Antidiabetic Medicinal Plants**

Gopalsatheeskumar K<sup>1\*</sup> and Kalaichelvan V K<sup>2</sup>

<sup>1</sup>Research Scholar, Department of Pharmacy, Annamalai University, Annamalai Nagar, Chidambaram, Tamil Nadu, India

<sup>2</sup>Associate Professor, Department of Pharmacy, Annamalai University, Annamalai Nagar, Chidambaram, Tamil Nadu, India

Received: 18 Jan 2020

Revised: 21 Feb 2020

Accepted: 25 Mar 2020

### **\*Address for Correspondence**

#### **Gopalsatheeskumar K**

Research Scholar,  
Department of Pharmacy,  
Annamalai University, Annamalai Nagar,  
Chidambaram, Tamil Nadu, India  
Email: gskpungai@gmail.com.



This is an Open Access Journal / article distributed under the terms of the **Creative Commons Attribution License** (CC BY-NC-ND 3.0) which permits unrestricted use, distribution, and reproduction in any medium, provided the original work is properly cited. All rights reserved.

### **ABSTRACT**

Diabetes mellitus is a group of metabolic syndrome characterized by fasting hyperglycemia, postprandial hyperglycemia and hyperlipidemia, resulting from defects in carbohydrate, fat and protein metabolism. The many factors are affected the diabetes such as lack of exercise, imbalanced diet, hormonal problem, etc. Now a days many of the synthetic drugs available to control diabetes such as biguanides, sulfonylureas, meglitinides, thiazolidinediones, dipeptidyl peptidase IV inhibitors, and  $\alpha$ -glucosidase inhibitors etc., and the treating of diabetes is still challenging one due to the extended prevalence of diabetes in world wide. Besides these treatments, a couple of scientific data have indicated that medicinal plant and their products possess antidiabetic properties with less toxicity and side-effects. For the biological standardization/screening of new herbal / herbal drug for antidiabetic activity, various methods are involved such as *in vitro* screening, *in vivo* screening. In diabetic research cell lines technology plays an important role because of its unique target specificity. Many of the researches were used different cell lines like L6, C2C12, 3T3-L, RIN5F, HepG2 etc., based on focus of mechanistic study. But still there is no collective data on screening of antidiabetic medicinal plants using cell line study. Sothat, this review is summarizes the information about the cell lines techniques used in diabetes research.

**Key words :** *In vitro*, Diabetes, Pancreas, Insulin, L6, Phytomedicine.





## INTRODUCTION

Diabetes is a metabolic disorder which is developed by improper working of insulin (insulin resistant) and or insufficient insulin production in human system. The elevation of blood glucose is known as diabetes (1). The many factors are affected the diabetes such as lack of exercise, imbalanced diet, hormonal problem, etc. It is recognized as the wide-reaching chronic disorder affecting almost people of all age groups. India (31.7 million) has topped the world with the highest number of people with diabetes mellitus followed by China (20.8 million) and United States (17.7 million) in second and third place respectively. According to a report of IDF 2017, there are 422 million people experiencing diabetes in the world and this figure is expected to rise 629 million in 2045 (2, 3).

Therefore, the management of diabetes mellitus is considered as a global problem and successful treatment is yet to be discovered. Nowadays, several synthetic drugs with anti-diabetic effects including oral synthetic hypoglycemic agents like sulfonylureas, insulin treatment and specific enzyme inhibitors are used for patients. However, these drugs are expensive and commonly associated with side-effects and drawbacks like insulin resistance, anorexia nervosa, brain atrophy, hepatotoxicity, abdominal pain, and flatulence, which limit their applications. Besides these treatments, a couple of scientific data have indicated that medicinal plant and their products possess antidiabetic properties with less toxicity and side-effects (4). For the biological standardization/screening of new herbal/herbal drug for antidiabetic activity, various methods are involved such as *in vitro* screening, *in vivo* screening. Many review papers were summarized the *in vitro* and *in vivo* techniques for antidiabetic drugs. But still proper review papers are not available for the screening of antidiabetic/herbal drugs using cell line technique so that, this review focused *in vitro* cell line studies for the biological screening of antidiabetic medicinal plants.

### Methods of cell line techniques

The various methods were used by the researchers to the screening of antidiabetic activity of herbal medicines/ extracts are following, and the details of the medicinal plants, cell lines and suitable mechanisms are mentioned in Table 1.

### MTT assay

The MTT assay is used for the selection of dose for the further analysis of plant extract/drugs for antidiabetic activity. This is one of the cytotoxicity studies, in this assay method 3-(4,5-Dimethylthiazol-2-yl)-2,5-diphenyltetrazolium bromide (MTT) is applied to evaluate cell viability. The cells are plated in 96-well plates and then allowed to attach to the plate for 24 h. Then different concentrations (Increasing concentration) of plant extracts are add to this for 20 h. The cell medium is then replaced with fresh medium/well containing MTT and cultivated for another 4 h darkened in the cells incubator. Then the supernatant is removed and add with isopropanol/HCl in every well. The absorbance at 570 nm is measured with microtiterplate reader. Two wells per plate without cells served as blank. The effect of the plants extracts on cell viability was expressed using the following formula (5):

$$\text{Percentage viability} = \frac{\text{Control} - \text{Sample}}{\text{Control}} \times 100$$

### GLUT4 translocation

The GLUT4 is measure by anti-myc antibody through antibody conjugate to horseradish peroxidase. The plant extracts, add in 24-well plates containing cells. Serum starved for 3 h are treated without or with insulin for 20 min, wash twice with ice-cold saline, fix for 10 min with 3% paraformaldehyde, incubation with glycine 0.1 M, blocked 10 min with 3% (v/v) goat serum and react with polyclonal anti-myc antibody (1:200) for 1 h at 4°C, wash 10 times with



**Gopalsatheeskumar and Kalaichelvan**

PBS and reacted with horseradish peroxidase-bound goat anti-rabbit secondary antibody (1:1000) for 1 h at 4°C, and washed with saline. Cells are then incubate with 1 mL ophenylenediaminedihydrochloride reagent and allow developing for 20–30 min in the linear range in the dark at room temperature. The reaction was stopped with 1 ml/well of 3 N HCl. Supernatants were collected and absorbance was measured at 492 nm. Background absorbances obtain in the absence of antimycantibody and are subtracted from all values (6).

**LDH leakage assay**

The permeability of cellular membranes following the exposures is determined by measuring the amount of released lactate dehydrogenase (LDH) enzyme from cells. Activity of LDH release to the cell culture medium is monitored following the formation of formation by coupled enzymatic reaction at 492 nm. Cell membrane rupture is defining as the ratio of LDH activity in the supernatant of treated cells to the LDH activity release in the control cells. The cells are plated in medium/well in 96-well plates and, allow to attach to the plate for 24 h. Cells are then treat with increasing concentrations of the plant extracts. The extracellular LDH activity is measure in the medium after 24 h. Therefore, each well is transfer to a new 96 well plate; the enzyme reaction is carryout.

**Glucose utilization assay**

In this assay method, all procedures are complete at 37°C. The incubation medium (8mM glucose RPMI 1640 + 0.1% BSA) containing the specific treatment (insulin or metformin as positive controls or extract) is add to the appropriate wells. Control wells contain incubation medium only. After incubation (3 h), cells are remove from each well and place into a new 96-well plate to which glucose oxidase reagent is add. The plates are further incubating for 15min at 37°C and the absorbance is measured at 492 nm. To calculate glucose utilization, the amount of glucose left in the medium after incubation is subtracted from the initial amount.

**Protein Tyrosine Phosphatase-1B (PTP-1B) inhibition assay**

PTP-1B inhibition assay is done using colorimetric, non-radioactive PTP-1B. In brief plant extracts/drugs are incubating with human recombinant PTP-1B enzyme at different concentration in 96 well flat bottom microtiter plates. After adding the substrate to each well plates are incubating at 30°C for 30 min. On termination of reaction release phosphate is determine by the addition of biomol red reagent. PTP-1B phosphatase acts on the phosphopeptide substrate and releases phosphate group. The activity of PTP-1B is measured in terms of release free phosphate. After adding biomol red to reaction wells, plate is kept for next 20 min to develop the color. On completion of incubation absorbance is measure at 620 nm (7).

**Oil-Red O staining**

Differentiate 3T3-L1 adipocytes are treat with the plant extracts/drugs for six days. Then the cells are wash two times with phosphate-buffered saline (PBS) and fix using 10% paraformaldehyde and finally wash with PBS. The fix cells are stain for 1 hour with 0.5% Oil-Red O, which is dilute with propyleneglycol and then washed with PBS. Lipid droplets are stain and photograph by light microscopy. Stained oil droplets are dissolving in isopropanol and quantifying by spectrophotometric analysis at 490 nm (8).

**Insulin secretion assay**

Glucose-induced insulin secretion assay, in this assay method the plant extracts/drugs are also study by enzyme-linked immunosorbent assay kit (9).



**Gopalasatheeskumar and Kalaichelvan****Effect of extract on apoptosis induced by STZ**

Streptozotocin (STZ) is a pancreas islets specific toxic compound. The cells are treated with plant extract/drugs in presence of STZ. The fluorescent intensity is measured using an FAC Scan after treating with PI staining. The degree of apoptosis is determined using Propidium iodide (PI) stain which intercalates into double stranded nucleic acids that can be excited by 488 nm lasers. The lysing solution containing the cells is then incubated in the dark at room temperature for 30 minutes and the fluorescent intensity is measured using a flow cytometer (10).

**CONCLUSION**

This review summarizes the various cell lines for the screening of antidiabetic activity of medicinal plants with suitable mechanism, this review will be useful for the screening of antidiabetic activity of newer drugs/medicinal plants.

**REFERENCES**

1. Patlak M. New weapons to combat an ancient disease: treating diabetes. Federation of American Societies for Experimental Biology Journal, 2002; 16:18-53.
2. Gopalasatheeskumar K, Ariharasivakumar G, Sengottuvel T *et al.*, Confirmation of Best Method for Detection of Alpha Amylase Activity of *Cucumis melo var agrestis* (Wild Musk Melon). J Adv Res BioChemPharma, 2019; 2(1):18-20.
3. Wild S, Roglic G, Green A, Sicree R, King H. Global prevalence of diabetes: estimates for the year 2000 and projections for 2030. Diabetes Care, 2004; 27:1047- 1053.
4. Switi BG, Krishna MG, Sandhya RM. Phytochemicals for Diabetes Management. Pharmaceutical Crops, 2014; 5:11-28.
5. Mosmann T. Rapid colorimetric assay for cellular growth and survival: Application to proliferation and cytotoxicity assays. Journal of Immunological Methods, 1983; 65:55–63.
6. Zeggwagh NA, Sulpice T, Eddouks M. Anti-hyperglycaemic and hypolipidemic effects of *Ocimum basilicum* aqueous extract in diabetic rats. American Journal of Pharmacology and Toxicology, 2007; 2(3):123–129.
7. Joshi P, Deora GS, Rathore V, Tanwar O, Rawat AK, Srivastava AK, Jain D. Identification of ZINC02765569: a potent inhibitor of PTP1B by vHTS. Med Chem Res, 2013; 22:28–34.
8. Hsieh TJ, Lin T, Hsieh PC, *et al.* Suppression of glutamine:fructose-6-phosphate amidotransferase-1 inhibits adipogenesis in 3T3-L1 adipocytes. J Cell Physiol, 2012; 227:108-115.
9. Arya A, Looi CY, Cheah SC, Mustafa MR, Mohd MA. Anti-diabetic effects of *Centratherum anthelminticum* seeds methanolic fraction on pancreatic cells,  $\beta$ -TC6 and its alleviating role in Type 2 diabetic rats. J Ethnopharmacol, 2012; 144:22-32.
10. Juan CM, Carmen M, Antonio A, Jorgina S, Jose MC. Vanadate fully stimulates insulin receptor substrate-1 associated phosphatidylinositol 3-kinase activity in adipocytes from young and old rats. FEBS Letters, 1998; 425:298-304
11. Sleman K, Bashar S, Yoel S, Hilal Z. *In vitro* evaluation of anti-diabetic activity and cytotoxicity of chemically analysed *Ocimum basilicum* extracts. Food Chemistry, 2016; 196:1066–1074.
12. Maryna V, Saartjie R, Lelethu CB, Johan L, Neil RC *et al.*, Antidiabetic screening and scoring of 11 plants traditionally used in South Africa. Journal of Ethnopharmacology, 2008; 119:81–86.
13. Mohammad FK, Arun Kumar R, Shahnaaz K, Mohd Kamil H, Arvind M, Devendra Singh N. *In vitro* and *in vivo* antidiabetic effect of extracts of *Melia azedarach*, *Zanthoxylum alatum*, and *Tanacetum nubigenum*. Integr med res, 2018; 7:176–183.
14. Sankaradoss N, Velayutham R, Vijayalakshmi A. *In vitro* Cytotoxicity and Glucose Uptake Activity of Gymnemic Acid Fraction of *Gymnema Sylvestre* Leaves. International Journal of Pharma Research and Health Sciences, 2016; 4 (2):1104-1109.





**Gopalsatheeskumar and Kalachelvan**

15. Bindu C, Rama Bhat P, Krishna Prasad G, Girish BC. Relative potency of antidiabetic effect of *Costusspeciosus* (koen. Ex retz.) Smith plant extract in mouse fibroblast cell line. International journal of research – Granthaalayah, 2016; 4(3):99-106.
16. Shah RA, Khan S, Vakil M, Qureshi MT. Evaluation of antidiabetic potential of *Withaniasomnifera* by glucose uptake assay on 3T3 F442A fibroblast (adipocyte) cells. Int J Pharm Sci Res, 2017; 8(1): 120-125.
17. Hsiu-Fang Y, Chi-Ting H, Tusty-Jiuan H, Fang-Rong C, Chin-Kun W. *In vitro* anti-diabetic effect and chemical component analysis of 29 essential oils products. Journal of food and drug analysis, 2015; 23:124-129.
18. Janani C, Kumari BDR. Antidiabetic activity of methanolic leaves extracts of transformed soybean in 3T3-L1 pre-adipocytes cell line. Int J Pharm Sci Res, 2017; 8(11):4732-4744.
19. SakthiPriyadarsini S, Kumar P, Abhishek A, Devendiran B, Venkat SK, Richie PR. Insulin secretagogue effect of roots of *Ravenalamadagascariensis*sonn. - an *in vitro* study. Asian J Pharm Clin Res, 2019; 12(2):176-179.
20. Ali F, Fatemeh N, Behzad S, Mohammad HF, Gholamreza B. Antidiabetic Mechanisms of *Rosa canina* Fruits: An *In vitro* Evaluation. Journal of Evidence-Based Complementary & Alternative Medicine, 2017; 22(1):127-133.
21. Qamar UA, Murni NS, Siti ZM, Jalifah L et al., Methylation and Acetylation Enhanced the Antidiabetic Activity of Some Selected Flavonoids: *In vitro*, Molecular Modelling and Structure Activity Relationship-Based Study. Biomolecules, 2018;8(149):1-22.
22. Rathinavelusamy P, Papiya M, Dinakar S, Venkatesan J. Antidiabetic Activity of *Pterospermumacerifolium* Flowers and Glucose Uptake Potential of Bioactive Fraction in L6 Muscle Cell Lines with Its HPLC Fingerprint. BioMed Research International, 2014; 2014:1-14.
23. Kelly J, Paul S, Michael C, Linda M. Dietary polyphenols decrease glucose uptake by human intestinal Caco-2 cells. FEBS Letters, 2005; 579:1653–1657.
24. Dhanya R, Arya AD, Nisha P, Jayamurthy P. Quercetin, a Lead Compound against Type 2 Diabetes Ameliorates Glucose Uptake via AMPK Pathway in Skeletal Muscle Cell Line. Front. Pharmacol. 8; 336:1-9.
25. Vishnu Prasad VN, Anjana T, Banerji A, Gopalakrishnapillai A. Gallic acid induces GLUT4 translocation and glucose uptake activity in 3T3-L1 cells. FEBS Letters, 2010; 584:531–536.
26. Fereshteh A, Tahereh V, Abdolrahim A et al., C2C12 Cell Line is a Good Model to Explore the Effects of Herbal Extracts on GLUT4 Expression and Translocation. Iranian journal of diabetes and obesity 2012; 4(4):143-151.
27. Ruiyi Y, Lu W, Jie X, Xiang L, Shan L, Shengxiang Q, Yingjie H, Xiaoling S. Treatment of type 2 diabetes mellitus via reversing insulin resistance and regulating lipid homeostasis *in vitro* and *in vivo* using Cajanonic acid A. International journal of molecular medicine, 2018; 42: 2329-2342.
28. Annapandian VM, ShanmugaSundaram R. *In vitro*Antidiabetic Activity of Polar and Nonpolar Solvent Extracts from *Leucasaspera* (Willd.) Link Leaves. Pharmacognosy Res, 2017; 9(3):261–265.
29. Pal A, Misra BB, Das SS, Gauri SS, Patra M, Dey S. Antidiabetic effect of *Cephalandraindica* Q in diabetic rats. Indian J Res Homoeopathy 2013;7(2):81-90.
30. Pareek A, Suthar M, Godavarthi A, Goyal M, Bansal V. Negative regulation of glucose uptake by *Costuspictus* in L6 myotube cell line. Journal of Pharmaceutical Negative Results, 2010; 1(1):24-26.
31. Soon HT, Chung YL, Hazrina H, Aditya A et al., Antidiabetic and Antioxidant Properties of Alkaloids from *Catharanthusroseus* (L.) G. Don. Molecules, 2013; 18:9770-9784.
32. Sangeetha D N, S Rajamani. *In vitro*Antidiabetic Activity of Methanolic Leaf Extract of *Indianthusvirgatus* (Roxb.) Suksathan and Borchs by Glucose Uptake Method. Pharmacog J. 2019;11(4):674-7.
33. Ganjaji MS, Meriga B, Hari B, Oruganti L, Dasari S, Mopuri R. PolyPhenolic rich fraction of *Terminaliapaniculata* attenuates obesity through inhibition of pancreatic amylase, lipase and 3T3-L1 adipocyte differentiation. Journal of Nutrition & Intermediary Metabolism, 2017; 10:19-25.
34. Gupta RN, Anil P, Manish S, Garvendra SR, Pawan KB, Deepti J. Study of glucose uptake activity of *Helicteresisora* Linn. fruits in L-6 cell lines. Int J DiabDevCtries, 2009; 29(4):170-173.





## Gopalasatheeskumar and Kalaihelvan

Table 1: Various cell lines for screening of antidiabetic medicinal plants with mechanism

Cell line	Method	Parameters	Herbal Drug/Extract	Mechanism	Author
L6 (Rat Skeletal muscle cell line)	LDH leakage assay GLUT4 translocation	Surface GLUT4myc, Surface myc tagged GLUT4	<i>Ocimum basilicum</i>	Increased GLUT4 translocation	Sleman <i>et al.</i> , (11)
C2C12 (Murine myoblasts), 3T3-L1 (pre-adipocytes)	Glucose utilization experiment	Glucose utilization	<i>Catha edulis</i> <i>Momordicafoetida</i> <i>Momordicabalsamina</i> <i>Sclerocaryabirrea</i> <i>Cannabis sativa</i> <i>Cissampeloscapensis</i> <i>Catharanthusroseus</i> <i>Psidiumguajava</i> <i>Chironiabaccifera</i> <i>Brachylaena discolor</i> <i>Vinca major</i>	-	Marynaet <i>al.</i> , (12)
C2C12	Assay	Measurement of 2-deoxy-D-[1-3H] glucose Protein Tyrosine Phosphatase-1B (PTP-1B) inhibition	<i>Meliaaz adarach</i> <i>Zanthoxylu malatum</i> <i>Tanacetum nubigenum</i>	InhibitPTP-1B activity and to stimulate the glucose uptake	Mohammadet <i>al.</i> , (13)
L6	Assay	Glucose uptake assay	Gymnemic acid	Increased GLUT4 translocation	Sankaradosset <i>al.</i> , (14)
3T3L1	Assay	Relative potency of insulin	<i>Costus speciosus</i>	-	Binduet <i>al.</i> , (15)
3T3-F442A (3T3-Adipocyte)	Glucose Uptake Assay	Percentage glucose uptake	<i>Withania somnifera</i>	-	Shahet <i>al.</i> , (16)
3T3-L1	Glucose consumption assay, Western blot	Percentage glucose consumption	Commercial essential oil (29 Medicinal Plants)	Expression levels of SREBP1 and C/EBPR but also effectson the AMPK/ACC pathway	Hsiu-Fanget <i>al.</i> , (17)
3T3-L1	Oil Red O Staining lipid accumulation	Percentage Relative lipid content	Iso flavones from Soybean	-	Jananiet <i>al.</i> , (18)
RIN5F (Rat insulinoma 5F cell lines)	Insulin secretion assay	Insulin release	<i>Ravenala madagascariensis</i>	Stimulating the insulin secretion	Sakthi Priyadarsiniet <i>al.</i> , (19)
β-TC6(Pancreas cell line)	Death Induced by STZ Assay	Inhibition of Death Induced by STZ Assay	<i>Rosa canina</i>	-	Ali Fattahiet <i>al.</i> , (20)
RIN-5F, 3T3-L1	Insulin Secretion Assay Adipogenesis Assay Glucose Uptake	Amount of insulin secretion Quantification of lipid droplet	Wogonin, Norwogonin, Techtochrysin	Improved insulin secretion, Upregulatory	Qamar Uet <i>al.</i> , (21)





## Gopalasatheeskumar and Kalaichelvan

	Assay Western Blotting Assay	Glucose uptake Leptin, Adiponectin, TNF, and RBP-IV		activity of glucose uptake, Regulatingadipo kines secretion, Activation of GLUT4	
L6	Glucose uptake assay	Percentage glucose uptake	<i>Pterospermu macerifolium</i>	Stimulation of glucose uptake mediated by GLUT4 translocation	Rathinavelusamye <i>t al.</i> , (22)
Caco-2 (Human epithelial colorectal adenocarcinom a cells)	Glucose uptake assays	Percentage glucose uptake	Arbutin, Naringin, Neohesperidindihydr ochalcone, Phloridzin, Rutin	-	Kellyet <i>al.</i> , (23)
L6	Intracellular Calcium Levels Quantitative Real Time PCR Analysis Western Blotting Immuno- fluorescence Assay	Membrane transient depolarization Change in membrane potential and intracellular calcium levels mRNA and protein expression	Quercetin	Boosted AMP into ATP ratio thereby atransitory alteration in mitochondrial membrane potentialActivati on of AMPK- target P38MAPK	Dhanyaet <i>al.</i> , (24)
3T3-L1 cells	GLUT4 translocation assay Glucose uptake assay Western blot analysis	Percentage increase in GLUT4 translocation, Percentage Glucose uptake	Gallic acid	Stimulates GLUT4 translocationand glucose uptake in an aPKCf/k dependent manner.	Vishnu Prasadet <i>al.</i> , (25)
C2C12	Western blotting	Percentage increase in GLUT4	Turmeric, Cinnamon		Fereshtehet <i>al.</i> , (26)
3T3-L1 mouse preadipocyte	Glucose consumption assay Western blot analysis	The expression levels of (A) PTP1B, (B) IRS1, (C) IRS2, (D) GSK3 $\beta$ and (E) GLUT1	<i>Cajanuscajan</i>	Inhibiting the activity of PTP1B, Activating insulin signaling transduction.	Yanget <i>al.</i> , (27)
C2C12	Glucose uptake assay	Percentage of glucose uptake activity	<i>Leucas aspera</i>		Annapandianet <i>al.</i> , (28)
3T3	Glucose uptake assay	Glucose uptake	<i>Cephalandra indica</i>	-	Pal et <i>al.</i> , (29)
L6	Glucose uptake activity	Glucose uptake activity	<i>Costuspictus</i>	-	Pareeket <i>al.</i> , (30)







**Gopalsatheeskumar and Kalaichelvan**

β-TC6, C2C12	Glucose Uptake Assay	Glucose uptake	<i>Catharanthus roseus</i>	PTP-1B Inhibition	Soon <i>et al.</i> , (31)
L-6	Glucose uptake assay	Glucose uptake	<i>Indianthus virgatus</i>	-	Sangeetha <i>et al.</i> , (32)
3T3-L1	Adipocyte differentiation Lipolysis- measurement of glycerol release	Lipid content Oil Red O staining	<i>Terminalia paniculata</i>	Attenuate obesity through inhibition of pancreatic lipase, amylase and adipogenesis of 3T3-L1 cells	Ganjayiet <i>al.</i> , (33)
L-6	Glucose uptake assay	Percentage of glucose uptake	<i>Helicteresisora</i>	Translocation of GLUT4 rapidly in intracellular membrane	Gupta <i>et al.</i> , (34)





## Application of Triadimefon Induced Changes on the Biochemical Contents of Sodium Chloride Stressed and Unstressed Green Gram Plants

S.N.Rajan<sup>1\*</sup> and L.Karikalan<sup>2</sup>

<sup>1</sup>Department of Botany, Raja Doraisingam Government Arts College, Sivagangai, Tamil Nadu, India.

<sup>2</sup>Department of Botany, Sethupathy government Arts College, Ramanathapuram, Tamil Nadu, India.

Received: 20 Jan 2020

Revised: 23 Feb 2020

Accepted: 25 Mar 2020

### \*Address for Correspondence

**S.N.Rajan**

Department of Botany,

Raja Doraisingam Government Arts College,

Sivagangai, Tamil Nadu, India.

Email: sreelakamrajan@gmail.com



This is an Open Access Journal / article distributed under the terms of the **Creative Commons Attribution License** (CC BY-NC-ND 3.0) which permits unrestricted use, distribution, and reproduction in any medium, provided the original work is properly cited. All rights reserved.

### ABSTRACT

Seeds of *Vigna radiata* were sown in plastic pots filled with the soil mixture containing red soil, sand and farm yard manure at 1:1:1 ratio. Before sowing the seeds, the pots were irrigated with deionised water (control), 80 mM NaCl, 80 mM NaCl combination with 15mg L<sup>-1</sup> triadimefon and 15mg L<sup>-1</sup> triadimefon solutions. The electrical conductivity (EC), of the soil mixture was measured and the EC level was found to be 0.10 dS m<sup>-1</sup> (control), 12.00 dS m<sup>-1</sup> (80 mM NaCl), 10.00 dS m<sup>-1</sup> (80 mM NaCl + 15 mg L<sup>-1</sup> triadimefon) and 1.13 dS m<sup>-1</sup> (15 mg L<sup>-1</sup> triadimefon) respectively. The pots were watered to field capacity with deionised water upto the 60th day. The initial EC level of the soil was maintained by flushing each pot with required volume of corresponding treatment solution on the 7th, 22nd, 37th and 52nd days. Plants were harvested randomly on the 15, 30, 45 and 60 DAS and used for studying Biochemical activity of *Vigna radiata*. The protein content was found to be decreased while free amino acid, proline and glycine betaine contents increased with sodium chloride stress. Triadimefon treatment to the sodium chloride stressed and unstressed plants increase the protein content and lowered the free amino acid, proline and glycine betaine contents. The increased protease activity and the increased free amino acid, proline contents can be well correlated in the NaCl stressed plants. Similarly the increased protein content and decreased amino acid and proline contents and protease activity in the triadimefon treated stressed and unstressed greengram plants finds a correlation.

**Key words:** NaCl stress, triadimefon, protein, amino acid, proline, glycine betaine.



**Rajan and Karikalan****INTRODUCTION**

Salinity causes a reduction in growth rate, yield and quality of crop (Abd El-Wahed *et.al.*,2015b; Hasan *et.al.*,2017), as well as changes in plant metabolic processes (Munns,2002). Irrigation water containing more dissolved salt is one of the main factors resulting in salt accumulation and decrease in soil fertility and also agricultural productivity in the arid regions of the world. Sodium ( $\text{Na}^+$ ) is the predominant soluble cation in most saline soils and water, particularly in coastal area. Most crop plants exhibit considerable hypersensitivity to saline environment because (i) intercellular accumulation of  $\text{Na}^+$  is toxic to the cellular metabolism, (ii) osmotic component of salinity stress causes water loss and inhibits growth (Serrano and Gaxiola, 1994) and (iii) it causes reduction in the water potential of the external medium. These effects are also due to a combination of adverse osmotic gradients and inhibitory effects of salts and ions on cell metabolism and of nutrient imbalance and secondary stresses such as an oxidative stress linked to the production of toxic reactive oxygen intermediates (Bajji *et.al.*,1998). Triazoles have been called “plant multi-protectants” because of their ability to induce tolerance in plants to environmental and chemical stresses.

**MATERIAL AND METHODS**

Seeds of *Vigna radiata* (L.) Wilczek cv. KM-2 (greengram) were obtained from Tamil Nadu Agricultural University Coimbatore, Tamil Nadu, India. The seeds were surface sterilized with 0.2 per cent  $\text{HgCl}_2$  solution for 5 minutes with frequent shaking and then thoroughly washed with deionised water. The seeds were pre-soaked in 500 ml of deionised water (control), 80mM NaCl, 80 mM NaCl + 15 mg  $\text{L}^{-1}$  triadimefon 25% WP ( Bayer, India Ltd.) and 15 mg  $\text{L}^{-1}$  triadimefon solutions for 12 hours. Seeds were sown in plastic pots (300 mm diameter) filled with 3 kg of soil mixture containing red soil, sand and farm yard manure (FYM) at 1:1:1 ratio. Before sowing the seeds, the pots were irrigated with the respective treatment solutions and the electrical conductivity (EC), of the soil mixture was measured and the EC level was found to be 0.10  $\text{dS m}^{-1}$  (control), 12.00  $\text{dS m}^{-1}$  (80 mM NaCl), 10.00  $\text{dS m}^{-1}$  (80 mM NaCl + 15 mg  $\text{L}^{-1}$  triadimefon) and 1.13  $\text{dS m}^{-1}$  (15 mg  $\text{L}^{-1}$  triadimefon) respectively. Four seeds were sown per pot and the pots were watered to the field capacity with deionised water upto 60 days after sowing (DAS) and every care was taken to avoid leaching. The initial EC level of the soil was maintained by flushing each pot with required volume of corresponding treatment solution at 7th, 22nd, 37th and 52nd days. The pot culture experiment was carried out in a completely randomized design (CRD) with 50 replicates for each treatment. The position of each pot was randomized at 4 days intervals to minimize spatial effects in the green house, where the temperature was 28° C during the day and 22° C at night and the relative humidity (RH) varied between 60-70 per cent. The seedlings were thinned to one per pot on the 10<sup>th</sup> day after sowing. Plants were harvested randomly on the 15, 30, 45 and 60 DAS and used for studying the Biochemical activity.

**RESULTS AND DISCUSSION****Soluble Protein Content**

The protein content was lowered by the NaCl stress in all parts of the greengram plants when compared to control and other treatments. Similar result was obtained in *Vigna radiata* (Sakhuja and Chawla, 1994) and *Crotalaria striata* (Chandrashekar and Sandhyarani, 1996). In germinating pea, salinity lowered the protein and peptide contents by stimulating protein hydrolysis which was considered to be a primary effect of salt stress (Upreti and Sarin, 1976). Protein degradation under saline environment has been attributed to the decrease in protein synthesis, accelerated proteolysis, decrease in availability of amino acid and denaturation of enzyme involved in protein synthesis (Poljakoff Mayber, 1982). However, slightly increased protein content was observed in the salt resistant varieties of barley, wheat and sunflower (Helal and Mengel, 1979; Saha and Gupta, 1993) and the salt resistant character might be the reason for the slightly increased protein content in these plants.





### Rajan and Karikalan

Addition of triadimefon to the NaCl stressed plants increased the protein content significantly, when compared with NaCl stressed plants. However, the increase is lower than that of control plants. Similar observation was also made in soybean and *Vigna unguiculata* with triadimefon treatment (Panneerselvam *et al.*, 1998; Gopi *et al.*, 1998) and in sunflower and mungbean with LAB-150978 treatment (Saha and Gupta, 1993). Triadimefon treatment to the stressed plants increased the protein content to a level more or less equal to that of control. Increased protein content with paclobutrazol, uniconazole treatments was observed in *Brassica carinata* (Setia *et al.*, 1995).

#### Free Amino Acids

The free amino acid content increased to a larger extent with NaCl stress in greengram when compared with control and other treatments. Increased amino acid level under salt stress was reported in bean (Anilkumar *et al.*, 1996), wheat (Hamada and Khulaef, 1995) and soybean (Panneerselvam *et al.*, 1998). Strogonov (1964) attributed this accumulation of amino acids to the hydrolysis of protein and this accumulated amino acid, may be occurring in response to the change in osmotic adjustment of their cellular contents (Greenway and Munns, 1980).

Triadimefon treatment to NaCl stressed plants markedly reduced the accumulation of amino acids when compared with NaCl stressed greengram plants. However, it is higher than that of control. Similar observation was made in NaCl stressed *Vigna unguiculata* seedlings with triadimefon treatment (Gopi *et al.*, 1998). Triadimefon treatment to the unstressed greengram plants slightly increased the amino acid content when compared to control. However, it is lower than that of other treatment. In sunflower and mungbean LAB-150978 increased the free amino acid content (Saha and Gupta, 1993). Decreased amino acid content and the increased protein content in the triadimefon treated NaCl stressed greengram could be well correlated.

#### Proline

The proline content increased to a large extent in the NaCl stressed greengram plants when compared with control and other treated plants. Increased proline content under NaCl stress was reported in *Guizotia abyssinica* (Sarvesh *et al.*, 1996) and greengram seedlings (Muthukumarasamy and Panneerselvam, 1997c). proline may act as a non-toxic osmotic solute, enzyme protector, stabilizer of structure of the macromolecules (Pahllich *et al.*, 1983) and major reservoir of energy and nitrogen for utilization during salinity as reported in *Aster trifolium* (Goas *et al.*, 1982).

The increase in proline content under NaCl stress is mainly due to the break-down of proline rich protein and fresh synthesis of proline and amino acid (Tewari and Singh, 1991) and it could be due to prevention of feed back inhibition of the biosynthetic enzyme caused by sequestering of proline away from its site of synthesis, or by relaxed feed back inhibition of the regulatory step enzyme (Widholm, 1988) or by decreased activity of enzyme involved in degradation of proline (Kandpal *et al.*, 1981). Increased proline in the stressed plants may be an adaptation to overcome the stress conditions. Proline accumulated under saline conditions supplies energy for growth and survival and thereby helps the plant to tolerate stress (Chandrashekar and Sandhyarani, 1996).

Triadimefon treatment to the NaCl stressed plants lowered the proline content to a large extent in greengram. However, the level is higher than that of control. Similar results have been obtained with triadimefon treatment in the NaCl stressed soybean (Panneerselvam *et al.*, 1998) and LAB-150978 treated sunflower and mungbean (Saha and Gupta, 1993). There was a remarkable increase in the proline content in thermally stressed paclobutrazol treated *Eruca sativa* seedlings (Mathur and Bohra, 1992). Triadimefon treatment to the unstressed greengram plants slightly increased the proline content when compared with control. However, it was lower than that of NaCl stressed triadimefon treated plants. Triadimefon and uniconazole treated mulberry plants recorded a significant increase in the proline content. This increase has been proportional to the concentration of the triazole used (Sreedhar, 1991). Plant hormones viz., abscisic acid, cytokinin and ethylene are known to play an important role on proline metabolism during the period of water deficit and recovery. Applied abscisic acid has been shown to induce proline





### Rajan and Karikalan

accumulation in both intact and excised leaves of barley. Hence, the stress protected conferred by triazole may, in part, be the result of its effect on the endogenous concentration of abscisic acid and associate with this is the increase in the concentration of proline (Aspinall *et al.*,1973).

The increased proline content can be correlated with the decreased protein content in the NaCl stressed plants and this decrease in protein infers the hydrolysis of protein or inhibition of protein synthesis by salinity leading to the accumulation of proline. This effect has been neglected by triadimefon with increased protein turnover and decreased hydrolysis.

#### Glycine Betaine

The glycine betaine content was found to be increased to a larger extent with NaCl stress in the greengram plants. Increasing glycine betaine level with increasing salt stress was reported in wheat and barley, (Araya *et al.*,1991). Aliphatic quaternary ammonium compounds (QAS) such as glycine betaine, stachydrine, homostachydrine, trigonelline have been found to accumulate in a large number of plants exposed to salt and water stress. The concentration, however, vary widely in different species and in different organs (Storey and Wyn-jones,1975). The accumulation of glycine betaine might serve as an intercellular osmoticum and it can be closely correlated with the elevation of osmotic pressure (Storey and Wyn-jones,1978).

Triadimefon treatment to the NaCl stressed greengram plants lowered the glycine betaine content significantly when compared with NaCl stressed plants. Triadimefon treatment to the unstressed plants slightly increased the glycine betaine content when compared to control. Triadimefon treatment seems to stimulate the glycine betaine synthesis in the unstressed greengram plants. However, triadimefon treatment to the NaCl stressed plants decreases the glycine betaine content.

#### CONCLUSION

The protein content was found to be decreased while free amino acid, proline and glycine betaine contents increased with sodium chloride stress. Triadimefon treatment to the sodium chloride stressed and unstressed plants increase the protein content and lowered the free amino acid, proline and glycine betaine contents. The increased protease activity and the increased free amino acid, proline contents can be well correlated in the NaCl stressed plants. Similarly the increased protein content and decreased amino acid and proline contents and protease activity in the triadimefon treated stressed and unstressed greengram plants finds a correlation.

#### REFERENCES

1. Abd-El-Wahed M.H., A.El Sabagh., H.Mohammed., A.Ueda., H.Saneoka and B.Celaleddin. 2015b. Evaluation of Barley productivity and water use efficiency under saline water irrigation in arid region. International journal of Agriculture and crop sciences, 8: 765-773.
2. Anilkumar S., M. Muthukumarasamy and R. Panneerselvam. 1996. Nitrogen metabolism in black gram under NaCl stress. J. Indian Bot. Soc., 75: 69-71.
3. Araya F., O. Abarca., G.E. Zuniga and L.J. Corcuera. 1991. Effect of NaCl on glycine-betaine and on aphides in cereal seedlings. Phytochemistry, 30(6): 1793-1795.
4. Aspinall d., T.N. Singh and L.G. Paleg. 1973. Stress metabolism V. abscisic acid and nitrogen metabolism in barley and *Lolium temulentum* L. Aust. J. Biol. Sci.,26: 319-327.
5. Bajji M., J. Kinet and S. Lutts. 1998. Salt stress effects on roots and leaves of *Atriplex halimus* L. and their corresponding callus cultures. Plant Sci., 137: 131-142.





### Rajan and Karikalan

6. Chandrashekar, K.R. and S. Sandhyarani. 1996. Salinity induced chemical changes in *Crotalaria striata* DC. Plants. Ind. J. Plant Physiol., New series,1(1): 44-48.
7. Goas, G., M. Goas and F. Larher. 1982. Accumulation of free proline and glycine betaine in *Aster trifolium* subjected to a saline shock: A kinetic study related to light period. Physiol. Plant., 55: 383-388.
8. Gopi, R., B.M.Sujatha, L.Karikalan and R.Panneerselvam. 1998. Triadimefon induced variation in growth and metabolism in the NaCl stressed *Vigna unguiculata* (L.) seedlings. Geobios, 25: 235-241.
9. Greenway, H and R. Munns. 1980. Mechanism of salt tolerance in non-halophytes. Ann. Rev. Plant Physiol., 31: 149-190.
10. Hamada, A.M. and E.M. Khulaef. 1995. Effect of salinity and heat-shock on wheat seedling growth and content of carbohydrates, proteins and amino acids. Biologia Plantarum, 37(3): 399-404.
11. Hasan, M.K., E.E.L.Sabagh, M.S.I.Sikdar, M.J.Alam, D.Ratnasekera, C.Barutcular, M.S.Islam. 2017. Comparative adaptable agronomic traits of black gram and mungbean for saline lands. Plants archives, 17(1): 589-593.
12. Helal, H. and K. Mengel. 1979. Nitrogen metabolism of young barley plants as affected by NaCl salinity and potassium. Plant and Soil, 51: 457-462.
13. Kandpal, R.P., C.S. Vaidyanathan, M. Udayakumar, K.S. Krishnasastry and N. Appaji-Rao. 1981. Alterations in the activities of the enzyme of proline metabolism in ragi (*Eleusine coracana*) leaves during water stress. . Biosciences, 3: 361-369.
14. Mathur, R. and S.P. Bohra. 1992. Effect of paclobutrazol on amino-transferases, protein and proline content in *Eruca sativa* var. T-23 seedlings. J. Phytol. Res.,5 (1&2): 93-95.
15. Munns,R. 2002. Comparative physiology of salt and water stress. Plant, cell and environment, 25(2); 239-250.
16. Muthukumarasamy, M. and R. Pannerseelvam. 1997c. Growth and biochemical changes of green gram under NaCl stress. Geobios, 24: 107-111.
17. Pahlich, E. R. Eerres and H.J. Jager. 1983. Influence of water stress on the vacuole / extra vacuole distribution of proline in protoplasts of *Nicotiana rustica*. Plant Physiol., 72: 590-591.
18. Panneerselvam, R., M. Muthukumarasamy and S.N.Rajan. 1998. Amelioration of NaCl stress by triadimefon in soybean seedlings. Biologia Plantarum, 41(1): 133-137.
19. Poljakoff-Mayber, A., 1982. Biochemical and physiological responses of higher plants to salinity stress. In : Bio-saline research. San Pietro, A., (ed.): A look to the future. Plenum Press, New York, pp. 245-269.
20. Saha.K. and K.Gupta. 1993. Effect of LAB-150978. A plant growth retardant on sunflower and mungbean seedlings under salinity stress. Indian J. Plant Physiol., 36(3): 151-154.
21. Sakhuja, A. and H.S. Chawla. 1994. Enzymatic changes in salt tolerant callus lines of mung been (*Vigna radiata* (L.) Wilczek). Acta Bot. Ind.,22:138-140.
22. Sarvesh,A., M. Anuradha, T. Pulliah, T.P.Reddy and P.B.Kavikishor. 1996. Salt stress and antioxidant response in high and low proline producing cultivars of niger, *Guizotia abyssinica* (L.F.) Cass. Indian J.EXP.Biol., 34:252-256.
23. Serrano, R. and R.Gaxiola .1994. Microbial models and salt stress tolerance in plants. CRC. Crit.Rev. Plant Sci., 13: 121-138.
24. Setia, R.C., G. Bhathal and N.Setia.1995. Influence of paclobutrazol on growth and yield of *Brassica carinata* A. Br. Plant Growth Regul., 16: 121-127.
25. Sreedhar,V.M., 1991. Proline accumulation and reduced transpiration in the leaves of trizole treated mulberry plant. Indian Bot. Repr., 10(1+2): 1-5.
26. Storey, R. and R.G. Wyn-Jones. 1975. Betaine and choline levels in plants and their relationship to NaCl stress. Plant Sci. Lett., 4: 161-168.
27. Storey, R. and R.G. Wyn-Jones. 1978. Salt stress and comparative physiology in the Gramineae. III. Effect of salinity upon ion relations and glycine betaine and proline levels in *Spartina x townsendii*. Aust. J. Plant Physiol., 5: 831-838.
28. Strogonov,B.P., 1964. Physiological basis of salt tolerance of plant. Acad. Sci. USSR, Davey and Co., New York.
29. Tewari, T.N. and B.B. Singh. 1991. Stress studies in lentil (*Lens esculenta Moench*). II. Sodicity-induced changes in chlorophyll, nitrate and nitrate reductase, nucleic acid, proline, yield and yield components in lentil. Plant and Soil, 136: 225-230.





**Rajan and Karikalan**

30. Uprety, D. C. and M.N.Sarin. 1976. Physiological studies on salt tolerance in *Pisum sativum* (L.). IV. Ionic composition and nitrogen metabolism. Acta Agron. Acad Sci. Hong., 25: 455-460.  
 31. Widholm, J.M., 1988. In vitro selection with plant cell and tissue culture. Iowa State Journal of Research, 62: 587-595.

**Table.1. Effect of NaCl, Triadimefon and their combination induced changes in the protein content of *Vigna radiate* (Values are the mean  $\pm$  SE of 3 replicates and expressed in mg g<sup>-1</sup> dry weight)**

Days After Sowing	Treatments				F ratio	LS (P-0.05)	Group Comparison
	Control	80 mM NaCl	80 mM NaCl +15 mg L <sup>-1</sup> Tri	15 mg L <sup>-1</sup> Tri			
	<b>ROOT</b>						
15	97.99 $\pm$ 1.99	83.50 $\pm$ 1.062	90.47 $\pm$ 2.15	104.44 $\pm$ 1.80	**	9.18	N <u>NT</u> C T
30	121.59 $\pm$ 2.81	96.37 $\pm$ 2.78	107.39 $\pm$ 3.16	121.86 $\pm$ 2.81	**	9.45	C <u>T</u> N T N
45	125.99 $\pm$ 3.64	103.35 $\pm$ 2.98	111.30 $\pm$ 3.22	126.29 $\pm$ 3.64	**	11.05	C T N <u>NT</u>
60	139.05 $\pm$ 4.08	106.33 $\pm$ 3.01	134.75 $\pm$ 4.16	142.63 $\pm$ 4.85	**	13.18	N C N <u>TT</u>
	<b>STEM</b>						
15	36.02 $\pm$ 1.66	28.46 $\pm$ 1.51	34.21 $\pm$ 1.73	41.34 $\pm$ 1.91	**	5.58	N <u>NT</u> C T
30	55.00 $\pm$ 1.91	48.19 $\pm$ 1.39	53.05 $\pm$ 1.53	56.59 $\pm$ 2.29	NS	5.92	N <u>NT</u> C T
45	64.00 $\pm$ 2.22	58.19 $\pm$ 1.68	62.32 $\pm$ 1.80	66.26 $\pm$ 2.68	NS	6.96	N <u>C</u> N <u>TT</u>
60	75.18 $\pm$ 2.60	69.32 $\pm$ 2.60	71.85 $\pm$ 1.73	77.03 $\pm$ 3.11	NS	8.37	C <u>N</u> N <u>TT</u>
	<b>LEAF</b>						
15	49.13 $\pm$ 1.99	36.80 $\pm$ 1.06	46.45 $\pm$ 2.15	51.78 $\pm$ 1.80	**	5.89	N <u>C</u> N <u>TT</u>
30	62.37 $\pm$ 2.16	49.74 $\pm$ 1.44	59.20 $\pm$ 1.71	63.71 $\pm$ 2.21	**	6.22	N <u>C</u> N <u>TT</u>
45	75.62 $\pm$ 2.18	62.48 $\pm$ 1.80	68.75 $\pm$ 2.38	79.21 $\pm$ 2.29	**	7.11	N <u>NT</u> C T
60	85.11 $\pm$ 2.46	65.05 $\pm$ 1.88	83.80 $\pm$ 4.49	88.90 $\pm$ 2.54	**	9.83	N C N <u>TT</u>

LSD – Least Significant Difference.

\*\* - Significantly different at 0.01 level and NS – Not Significant.

C – Control, N – NaCl, NT – NaCl + Triadimefon, Tri and T – Triadimefon.

Treatments connected by bars does not show LSD.

**Table.2 Effect of NaCl, Triadimefon and their combination induced changes in the amino acid content of *Vigna radiate* (Values are the mean  $\pm$  SE of 3 replicates and expressed in mg g<sup>-1</sup> dry weight)**

Days After Sowing	Treatments				F ratio	LSD (P-0.05)	Group Comparison
	Control	80 mM NaCl	80 mM NaCl +15 mg L <sup>-1</sup> Tri	15 mg L <sup>-1</sup> Tri			
	<b>ROOT</b>						
15	4.959 $\pm$ 0.143	12.423 $\pm$ 0.287	7.587 $\pm$ 0.175	5.265 $\pm$ 0.122	**	0.628	C T N <u>NT</u>
30	6.744 $\pm$ 0.168	17.600 $\pm$ 0.610	9.413 $\pm$ 0.272	7.145 $\pm$ 0.206	**	0.371	C N <u>NT</u> T
45	10.640 $\pm$ 0.307	22.774 $\pm$ 0.394	16.171 $\pm$ 0.467	12.548 $\pm$ 0.362	**	0.668	C N <u>NT</u> T
60	14.828 $\pm$ 0.139	33.760 $\pm$ 0.023	24.144 $\pm$ 0.156	16.658 $\pm$ 0.118	**	0.896	C N <u>NT</u> T
	<b>STEM</b>						
15	2.603 $\pm$ 0.090	5.970 $\pm$ 0.207	4.132 $\pm$ 0.095	3.095 $\pm$ 0.260	**	0.498	C T N <u>NT</u>
30	3.439 $\pm$ 0.099	8.580 $\pm$ 0.248	5.034 $\pm$ 0.145	4.117 $\pm$ 0.119	**	0.533	C <u>N</u> N <u>TT</u>
45	6.740 $\pm$ 0.175	15.645 $\pm$ 0.451	11.775 $\pm$ 1.369	7.526 $\pm$ 0.217	**	0.798	C T N <u>NT</u>

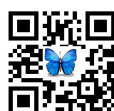



Rajan and Karikalan

60	9.421±0.070	21.489±0.017	14.748±0.097	10.573±0.072	**	0.821	C N NT T	
			<b>LEAF</b>					
15	6.192±0.179	12.035±0.278	8.158±0.236	6.670±0.193	**	0.733	C T N NT	
30	7.105±0.205	15.218±0.527	10.711±0.309	8.093±0.234	**	1.021	C T N NT	
45	17.783±0.410	31.985±0.923	23.861±0.689	18.953±0.438	**	2.121	C T N NT	
60	19.122±0.177	34.536±0.052	27.551±0.201	20.663±0.180	**	4.286	C T N NT	

LSD – Least Significant Difference.

\*\* - Significantly different at 0.01 level.

C – Control, N – NaCl, NT – NaCl + Triadimefon, Tri and T – Triadimefon.

Treatments connected by bars does not show LSD.

**Table 3. Effect of NaCl, Triadimefon and their combination induced changes in the proline content of *Vigna radiate* (Values are the mean ± SE of 3 replicates and expressed in mg g<sup>-1</sup> dry weight)**

Days After Sowing	Treatments				F ratio	LSD (P-0.05)	Group Comparison
	Control	80 mM NaCl	80 mM NaCl +15 mg L <sup>-1</sup> Tri	15 mg L <sup>-1</sup> Tri			
			<b>ROOT</b>				
15	0.377 ± 0.011	0.518 ± 0.015	0.477 ± 0.014	0.412 ± 0.012	**	0.042	C T N NT
30	0.612 ± 0.016	0.883 ± 0.021	0.739 ± 0.019	0.671 ± 0.018	**	0.063	C T N NT
45	0.829 ± 0.019	0.939 ± 0.027	0.915 ± 0.027	0.855 ± 0.025	*	0.080	C T NT N
60	0.942 ± 0.027	1.183 ± 0.041	1.112 ± 0.032	1.058 ± 0.031	**	0.108	C N NT T
			<b>STEM</b>				
15	0.416 ± 0.012	0.637 ± 0.018	0.495 ± 0.020	0.433 ± 0.013	**	0.053	C T N NT
30	0.461 ± 0.010	0.785 ± 0.023	0.575 ± 0.017	0.506 ± 0.046	**	0.054	C T N NT
45	0.518 ± 0.015	0.867 ± 0.025	0.706 ± 0.024	0.644 ± 0.052	**	0.068	C N NT T
60	0.997 ± 0.029	1.337 ± 0.039	1.129 ± 0.032	1.066 ± 0.031	**	0.107	C T NT N
			<b>LEAF</b>				
15	0.684 ± 0.010	0.769 ± 0.023	0.710 ± 0.017	0.700 ± 0.046	NS	0.068	C T NT N
30	0.771 ± 0.020	0.956 ± 0.028	0.874 ± 0.030	0.829 ± 0.024	**	0.084	C T NT N
45	0.883 ± 0.020	1.121 ± 0.032	1.011 ± 0.029	0.957 ± 0.027	**	0.090	C T NT N
60	1.119 ± 0.032	1.383 ± 0.040	1.195 ± 0.035	1.128 ± 0.032	**	0.115	N C NT T

LSD – Least Significant Difference.

\*\* - Significantly different at 0.01 level, \*0.05 level and NS – Not Significant.

C – Control, N – NaCl, NT – NaCl + Triadimefon, Tri and T – Triadimefon.

Treatments connected by bars does not show LSD.







## Rajan and Karikalan

**Table 4. Effect of NaCl, triadimefon and their combination induced changes in the glycine betaine content of *Vigna radiata* (Values are the mean  $\pm$  SE of 3 replicates and expressed in  $\mu\text{g g}^{-1}$  dry weight)**

Days After Sowing	Treatments				Fratio	LSD (P-0.05)	Group Comparison
	Control	80mM NaCl	80 mM NaCl +15 mg L <sup>-1</sup> Tri	15 mg L <sup>-1</sup> Tri			
			<b>ROOT</b>				—
15	13.212 $\pm$ 0.404	19.463 $\pm$ 0.693	16.314 $\pm$ 0.462	15.614 $\pm$ 0.462	**	1.713	C N N T T
30	17.464 $\pm$ 0.491	28.203 $\pm$ 0.982	23.386 $\pm$ 0.843	20.475 $\pm$ 0.577	**	2.521	C N N T T
45	33.257 $\pm$ 1.156	56.896 $\pm$ 5.112	51.389 $\pm$ 1.560	37.564 $\pm$ 1.095	**	4.602	C T N N T
60	54.271 $\pm$ 1.559	83.811 $\pm$ 2.425	74.997 $\pm$ 2.136	61.983 $\pm$ 5.659	**	6.027	C N N T T
			<b>STEM</b>				—
15	12.280 $\pm$ 0.421	17.312 $\pm$ 0.510	15.199 $\pm$ 0.485	13.388 $\pm$ 0.437	**	1.287	C T N N T
30	18.341 $\pm$ 0.606	26.059 $\pm$ 0.931	21.850 $\pm$ 0.201	19.845 $\pm$ 0.596	*	5.008	N N T T C
45	26.932 $\pm$ 1.097	47.255 $\pm$ 1.386	40.549 $\pm$ 1.155	32.238 $\pm$ 0.924	**	3.801	C N N T T
60	41.774 $\pm$ 1.443	69.524 $\pm$ 2.021	63.714 $\pm$ 1.848	52.794 $\pm$ 1.501	**	5.728	C N N T T
			<b>LEAF</b>				—
15	27.800 $\pm$ 0.981	38.503 $\pm$ 1.328	34.901 $\pm$ 0.981	29.599 $\pm$ 0.866	**	3.309	C T N N T
30	39.180 $\pm$ 1.328	67.029 $\pm$ 1.501	46.797 $\pm$ 1.328	42.988 $\pm$ 1.212	**	4.602	C T N T N
45	57.430 $\pm$ 1.461	73.137 $\pm$ 2.540	65.832 $\pm$ 1.212	60.434 $\pm$ 1.732	**	6.011	C T N T N
60	78.720 $\pm$ 2.252	94.826 $\pm$ 3.291	86.222 $\pm$ 2.483	82.318 $\pm$ 1.155	**	8.416	C N T T N

LSD – Least Significant Difference.

\*\* - Significantly different at 0.01 level and \*0.05 level.

C – Control, N – NaCl, NT – NaCl + Triadimefon, Tri and T – Triadimefon.

Treatments connected by bars does not show LSD.





## Influence of Sodium Chloride on Growth, ATPase, Nitrate Reductase Activity of *Salicornia brachiata* Roxb. and *Arthrocnemum indicum* Wild.

A. Venkatesan<sup>1\*</sup>, L. Karikalan<sup>3</sup> and G. Mathan<sup>2</sup>

<sup>1</sup>Associate Professor, Department of Botany, Annamalai University, Annamalai Nagar, Tamil Nadu, India.

<sup>2</sup>Department of Botany, Annamalai University, Annamalai Nagar, Tamil Nadu, India.

<sup>3</sup>Department of Botany, Sethupathy Government Arts College, Ramanathapuram, Tamil Nadu, India.

Received: 18 Jan 2020

Revised: 20 Feb 2020

Accepted: 25 Mar 2020

### \*Address for Correspondence

#### A. Venkatesan

Associate Professor,  
Department of Botany,  
Annamalai University,  
Annamalai Nagar,  
Tamil Nadu, India.

Email: venkatesan2k@yahoo.com



This is an Open Access Journal / article distributed under the terms of the **Creative Commons Attribution License** (CC BY-NC-ND 3.0) which permits unrestricted use, distribution, and reproduction in any medium, provided the original work is properly cited. All rights reserved.

### ABSTRACT

Salinity is one of the major environmental stress that can limit the growth and development of salt sensitive plants. Crop plants are very sensitive to the presence of high concentration of salt. The present study deals with the investigation on the effect of exogenous addition of various concentrations of sodium chloride on growth development and the activity of certain key enzymes of *Salicornia brachiata* and *Arthrocnemum indicum*. Both species, *Salicornia brachiata* survived a wide range of sodium chloride salinity ranging from 100mM to 700mM and *Arthrocnemum indicum* ranging from 100mM to 600mM respectively. The upper limit for the survival of these two species of NaCl was 700mM in *Salicornia brachiata* and 600mM in *Arthrocnemum indicum*. The results on the present study indicate that the optimal level of salt concentration for the overall better performance of these seedlings was 400mM (*Salicornia brachiata*) and 300mM (*Arthrocnemum indicum*) respectively. The sodium chloride salinity stimulated the growth rate such as shoot and root length (cm plant<sup>-1</sup>), fresh and dry weight of shoot and root (g plant<sup>-1</sup>) increased upto optimum level of 400mM and 300mM respectively and thereafter drastically reduced the growth rate. The enzymatic activity such as ATPase and Nitrate Reductase activity increased upto extreme level of 700mM and 600mM respectively. Generally both plants were tolerated high soil salinity and also accumulated more salt in soil and stored in shoot region.

**Key words:** Seedlings, *Salicornia brachiata*, *Arthrocnemum indicum*, ATPase, Nitrate Reductase.





## INTRODUCTION

Soil salinity is one of the important factors that limit plant growth and productivity. Plants are subjected to both osmotic stress (reduction in water availability) and  $\text{Na}^+$  and  $\text{Cl}^-$  toxicity under saline condition (Munns 2002). The  $\text{C}_4$  grass, *Salicornia brachiata* and *Arthrocnemum indicum* grows in the higher share of salted and brackish marshes tolerate coastal seawater salinity and the salinity fluctuation from water evaporation and tidal inundation approximately from 300mM to 600mM. The salinity tolerance mechanism of both species include cellular organizational and whole plant adaptation, like ion compartmentation (Spickett et al. 1993), presence of saline glands on the leaves, ion exclusion at the root (Bradley and Morris 1991) and ion partitioning different in organs. Ion exchange across the tonoplast and plasma membrane in order to  $\text{Na}^+$  concentration in the cytoplasm is the key cellular factor in salinity tolerance. The importance of plasmamembrane in plant salt tolerance has been suggested from studies on both glycophytes and halophytes (Blits and Gallaghar 1990).

The regulation of ion across the plasmamembrane is thought to be achieved by an electrochemical gradient generated by plasmamembrane  $\text{H}^+$ -ATPase as regulated by light and hormones and is sensitive to cell turgor change in *Cakile maritima* (Debez and Abdelly 2006 and Ellouzi et al. 2011), *Atriplex lentiformis* and *Chenopodium quinoa* (Bose et al. 2015). The plasmamembrane  $\text{H}^+$ -ATPase was stimulated in *Salicornia bigelovii* (Torr), when the plant was stimulated upto 200mM NaCl (Ayala et al. 1996) and in *Atriplex nummularia* (Braun et al. 1986). So, a study was carried out to investigate the influence of Sodium chloride on growth and ATPase, Nitrate Reductase activity of *Salicornia brachiata* and *Arthrocnemum indicum*

## MATERIALS AND METHODS

The one month old seedlings of *Salicornia brachiata* and *Arthrocnemum indicum* were collected from Pichavaram mangrove area, Cuddalore District, Tamil Nadu. These seedlings were planted in the polythene bags (12" × 10") to establish for 30 days. Well established plants were selected and treated with various concentrations of NaCl ranging from 100 to 700 mM. The treatment continues for ten days, after completing the treatment these seedlings were irrigated with tap water. The control plants were maintained without the addition of salt (only tap water). The samples were collected periodically at monthly intervals to analyse the growth parameters and biochemical studies. The shoot and root growth measured by scale and the fresh and dry weight was weighed by electronic balance.

Leaf  $\text{H}^+$ -ATPase activity was measured according to Kayro et al. (1993). Freshly harvested samples were ground in liquid nitrogen and homogenized in 50 mM HEPES/KOH (pH 7.4)(0.2g ml<sup>-1</sup>) containing 400mM sorbitol and 2 mM  $\text{MgCl}_2$ , the suspension was filtered through 30 $\mu\text{m}$  pore size nylon net, incubated in 50 mM HEPES (pH 7.4)(0.2g ml<sup>-1</sup>) containing 10 mM KCl, 400 mM sorbitol, 2 mM  $\text{MgCl}_2$ , 0.5 mM ATP and  $\lambda 1$  [ $\lambda$ -32-p] ATP (10MBq) (Hartmann Analytic, Braunschweig Germany) and kept in a water bath (30°C) for 15 minutes. After the reaction was stopped with  $\text{HClO}_4$  (final concentration 0.3 M), the samples were centrifuged for 5 min. at 9000 x g. The supernatant (200ml) was mixed with 1ml of ammonium heptamolybdate ( $(\text{NH}_4)_6\text{Mo}_7\text{O}_{24} \cdot 4\text{H}_2\text{O}$ ), previously diluted in  $\text{HClO}_4$  (1%w/v). Fifty microliter from each sample were used to determine the  $\lambda$ -32-pi total activity scintillation counting with a LS 801; Beckmann Inst. Ca, toluol/iso-butanol (1:1,v/v). The organic phase (500 $\mu$ l) was then added to 2ml of the ATPase activity and measurements were performed in an incubation medium containing their specific inhibitors 40 mM  $\text{KNO}_3$ , 1 mM  $\text{NaNO}_3$  and 0.4 mM 205, respectively. Enzyme activity was expressed as  $\mu\text{mol } 32 \text{ protein}^{-1}\text{m}^{-2}$  (three replicates per treatment).

NR was assayed based on the methods of Sagi et al. (1997). Leaf samples from control and NaCl treated plants were frozen in liquid nitrogen immediately after harvesting. Crude extracts were obtained by maceration with acid washed sand in an ice-cold extraction medium containing 25 mM Tris -HCl (pH 8.5), 3mM dithiothreitol, 1mM ethylene diaminetetraacetate. 10 $\mu$ M flavine adenine dinucleotide sodium salt, 1 $\mu$ M sodium molybdate, 2% (w/v)



**Venkatesan et al.**

casein, 10  $\mu$ M leupeptin, 5mM reduced glutathione and 3% (w/v) polyvinylpyrrolidone. The homogenate was centrifuged at 30,000 g for 15 min in a refrigerated centrifuge (Beckman, L7 ultra centrifuge, USA) at 4°C. The resulting supernatant was used for assay for NR and NO<sub>3</sub>. The activity of NR (E.C.1.6.6.1) was assayed in a modified reaction mixture containing 15 mM K-phosphate buffer (pH 7.5), 2 mM Tris-HCl buffer (pH 7.5), 12.5 mM KNO<sub>3</sub> and 0.4 mM nicotinamide adenine dinucleotide (reduced) by nitrite accumulation, which was analyzed by sulphanilamide and N-(1-naphthyl) ethylenediamine dihydrochloride addition and subsequent measurement of absorption at 540 nm. Protein concentration in the enzyme extract was determined following the procedure of Bradford (1976) using bovine serum albumin (BSA) as a standard one unit of NR was defined as the amount that will produce  $\mu$ mol of nitrite per h under the condition of the assay.

Dried soil sample weighing 10g was mixed with 50ml of distilled water and stirred well, pH of the solution was measured with a pH meter and the electrical conductivity was measured using a conductivity bridge and the data are given in Table II.

## RESULT AND DISCUSSION

Sodium chloride salinity increased the shoot length, root length and also fresh weight and dry weight of the same up to optimal level 400 mM in *Salicornia brachiata* and 300 mM in *Arthrocnemum indicum* (Table Ia and Ib) and there after decreased with increasing concentration. They were low in control because of reduced water absorption. This decrease in growth can be considered a mechanism to minimise water loss by transpiration (Motos et al. 2017). The fresh weight increase was largely attributed to cell enlargement by water absorption, cell vacuolation and turgor driven wall expansion. Similar observation has been observed in certain other halophytes such as *Mesembryanthemum crystallinum* (Slesal et al. 2008). The dry weight increase may be attributed to the accumulation of organic and inorganic constituents in their tissues. The same observation was observed in *Atriplex lentiformis* and *Chenopodium quinoa* (Bose et al. 2015), *Aegiceras corniculatum* (Manikandan and Venkatesan 2004).

Accumulation of high Na<sup>+</sup> in the cytosol can not only cause K<sup>+</sup> deficiency and thus disturb various enzymatic process, but also impose an energetic burden on the cell owing to the requirement of organic solute synthesis to compensate for exopt of Na<sup>+</sup> for osmotic adjustment (Munns and Tester 2008). K<sup>+</sup> acts as intrinsic uncouples of plasmamembrane H<sup>+</sup>-ATPase and its binding to the cytoplasmic phosphorylation domain site involving Asp<sup>617</sup> amino acid residue induces dephosphorylation of plasma membrane H<sup>+</sup>-ATPase (Buch-pederson et al. 2006). The NaCl salinity stimulated ATPase activity with increasing concentrations up to extreme level of 700mM and 600mM are represented in Fig-1. There was a significant increase on plasmamembrane H<sup>+</sup>-ATPase of *Atriplex lentiformis* and *Chenopodium quinoa* (Bose et al. 2015) and *Cakile maritime* (Debez and Abdely 2006). There was a significant increase of plasma membrane H<sup>+</sup>-ATPase in *Suaeda salsa* with compartmentalized toxicity and Na<sup>+</sup> in the vacuoles. Therefore membrane bound transport system regulating cytosolic ion homeostasis (Na<sup>+</sup>/K<sup>+</sup> and Ca<sup>2+</sup>) and ion accumulation in the vacuole can be considered as vital importance for adaptation to saline condition (Hasegawa et al. 2000). The capacity of Na<sup>+</sup> transport from the cytoplasm into the vacuole via the tonoplast Na<sup>+</sup>/H<sup>+</sup> antiport is dependent on the activity of V-ATPase which establish an electrochemical H<sup>+</sup> gradient across the tonoplast of energies transport of Na<sup>+</sup> against the concentration gradient (Wang et al. 2003)

The results on the effect of NaCl salinity on Nitrate Reductase activity in *Salicornia brachiata* and *Arthrocnemum indicum* showed that the enzyme activity was stimulated upto 700 mM and 600mM are represented in Fig -2. Nitrate Reductase is the first enzyme in the pathway of nitrate assimilation and catalyse the reduction of nitrate to nitrite to which is further reduced to ammonium and it is the key enzyme for nitrogen assimilation in multiple organisms (Chamizo-Ampudia et al. 2017 and Wu 2018). NR is responsive for metabolic and physiological status of plants. Hence, it often used as indicator of plant stress (Sacala et al. 2005), the nitrate reductase enzyme itself, represents very small proportion of leaf protein, the activity of the enzyme plays a vital role in the supply of nitrogen and the growth





### Venkatesan et al.

productivity of plants especially in cereals. It is a well established fact that high salt concentration inhibits nitrate reduction activity. The reduced nitrate reductase activity in the leaves of salt stressed plants is attributed to salt inhibited nitrate transport to the shoot, which in turn is due to interference with nitrate uptake and xylem loading (Sacala et al. 2005).

## CONCLUSION

It is concluded that these two species could be recommended for cultivation in salt affected soils to reclamate the soil salinity level and this soil is reused for further crop improvement.

## REFERENCES

1. Ayala F, O'Leary JW, Schumaker KS.1996. Increased vacuolar and plasma membrane H<sup>+</sup>-ATPase activities in *Salicornia bigelovii* Torr. in response to NaCl. Journal of Experimental Botany 47, 25–32.
2. Blits KC and Gallagher JL 1990. Effect of NaCl on lipid content of plasma membrane of the dicot halophyte, *Kosteletzkya virginica* (L). Presl. Plant Cell Reports. 9: 156-59.
3. Bose J, Rodringo-Moreno A, Lai D, xie Y, and Gregy S 2015. Plasma membrane H<sup>+</sup>-ATPase activity is essential to salinity tolerance in two halophyte species, *Atriplex lentiformis* and *Chenopodium quinoa*. Annuals of Botany. 115:481-494.
4. Bradley PM and Morris JT 1991. Relative importance of ion exclusion, secretion and accumulation in *Spartina alternifolia* Loisel. Journal of Experimental Botany. 42: 1525-32.
5. Braun Y, Hassidim M, Lerner HR and Reinhold L 1986. Studies on H<sup>+</sup>-ATPase translocating in plants of varying resistance to salinity. Salinity during growth modulates the proton pump in the halophytes *Atriplex nummularia*. Plant Physiology. 81: 1050-56.
6. Buch-pedersen MJ, Rudasherskaya EL, Berner TS, Venema K and Palmgren MG. 2006. Potassium as an intrinsic uncoupler of the plasma membrane H<sup>+</sup>-ATPase. Journal of Biological Chemistry. 281(50): 38285-38292.
7. Chamizo-Ampudia A, Sanz-Luque E, Llamas A, Galvan A, and Fernandez E 2017. Nitrate reductase regulates plant nitric oxide homeostasis. Trends Plant Sci. 22: 163–174.
8. Debez A and Abdely C 2006. Leaf H<sup>+</sup>-ATPase activity and photosynthetic activity of *Cakile maritima* under increasing salinity. Environmental and Experimental Botany. 57(3): 285-295.
9. Ellouzi H, Ben Hamed K, Munne-Bosch CS and Abdely C 2011. Early effect of salt stress on the physiological and oxidative status of *Cakile maritima* (halophyte) and *Arabidopsis thaliana* (glycophyte). Physiologia Plantarum. 142(2): 128-143.
10. Wu H 2018. Plant salt tolerance and Na<sup>+</sup> sensing and transport. The Crop Journal. 6(3): 215-225.
11. Manikandan T and Venkatesan A 2004. Influence of NaCl on growth, organic constituents and certain antioxidant enzymes of *Aegiceras corniculatum* Blanco. Geobios. 31: 30-33.
12. Motos JRA, Ortuno MF, Vicente AB, Vivancos PD, Blanco MJS and Hernandez JA 2017. Review, Plant Responses to Salt Stress: Adaptive Mechanisms. Agronomy: 2-38.
13. Munns R 2002. Comparative physiology of salt and water stress. Plant Cell Environment. 25: 239-250.
14. Munns R and Tester M 2008. Mechanism of salinity tolerance. Annual Review of Plant Biology. 59: 651-681.
15. Sacals E, Biegum A, Demczuk A and Grzyis E 2005. Effect of NaCl and supplemental calcium on growth parameters and nitrate reductase activity in maize. Acta Societatis Botanicorum Poloniae . 74(2): 119-123.
16. Slesak I, Libik M and Miszaliski Z 2008. The foliar concentration of hydrogen peroxide during salt induced C<sub>3</sub>-CAM transition in *Membryanthemum cystalinum* L. Plant Science. 221-226.
17. Spickelt CM, Smirnoff N and Ratcliffe RG 1993. An in vivo nuclear magnetic resonance investigation of ion transport in maize (*Zea mays*) and *Spartina anglica* roots during exposure to high salt concentrations. Plant Physiology. 102: 629-32.





**Venkatesan et al.**

18. Wang W, Vinocur B and Altrnan A 2003. Plant responses to drought, salinity and extreme temperature towards genetic engineering for salt stress tolerance. *Planta*. 218: 1-4.

**Table 1: Effect of NaCl on the height of plant (cm/plant), fresh weight and Dry weight (g/plant) of *Salicornia brachiata* on 120<sup>th</sup> day after treatment**

Concentration of NaCl mM	<i>Salicornia brachiata</i>					
	Length (cm/plant)		Fresh weight(g/plant)		Dry weight(g/plant)	
	Shoot	Root	Shoot	Root	Shoot	Root
0	24.30 ±1.45	12.9 ±0.77	13.5±0.79	7.20±0.43	5.2±0.31	3.2±0.13
100	29.70 ±1.78	14.97 ±0.89	14.9±0.87	8.6±0.516	5.6±0.33	2.7±0.15
200	32.50 ±1.95	16.2 ±0.97	17.1±0.99	9.9±0.55	6.2±0.37	2.8±0.16
300	34.50 ±2.07	17.49 ±1.04	21.5±1.29	12.5±0.65	7.3±0.43	3.7±0.21
400	40.40 ±2.42	18.60 ±1.11	24.9±1.70	14.2±0.97	8.8±0.52	3.0±0.19
500	33.4 ±2.00	16.40 ±0.98	19.8±1.16	11.6±0.63	7.4±0.44	2.9±0.18
600	30.60 ±1.83	15.80 ±0.94	16.5±0.99	10.2±0.57	6.5±0.42	2.6±0.15
700	20.30 ±0.13	14.50 ±0.87	14.3±0.85	8.5±0.51	5.8±0.35	2.2±0.12

**Table 2: Effect of NaCl on the height of plant (cm/plant), fresh weight and Dry weight (g/plant) of *Arthrocnemum indicum* on 120<sup>th</sup> day after treatment**

Concentration of NaCl mM	<i>Arthrocnemum indicum</i>					
	Length (cm/plant)		Fresh weight(g/plant)		Dry weight(g/plant)	
	Shoot	Root	Shoot	Root	Shoot	Root
0	17.40±1.04	10.50±0.63	10±0.49	4.6±0.27	3.1±0.18	1.2±0.07
100	21.35±1.28	12.55±0.75	12.5±0.86	5.8±0.38	3.8±0.23	1.6±0.09
200	23.6±1.41	13.90±0.83	13.2±0.81	8.2±0.49	4.6±0.27	1.9±0.11
300	28.6±1.71	15.80±0.94	16.2±0.97	9.3±0.55	5.5±0.33	2.6±0.15
400	25.9±1.53	12.6±0.75	14.3±0.85	8.1±0.43	4.4±0.29	2.1±0.12
500	23.40±1.40	11.9±0.73	12±0.72	7.2±0.43	3.2±0.24	1.8±0.10
600	20.10±1.20	8.20±0.55	10.5±0.63	6.3±0.37	2.8±0.16	1.5±0.09

**Table 3: Effect of NaCl on soil pH and Electric conductivity**

Concentration of NaCl (mM)	After treatment	
	pH	EC (mm hos/cm)
0	7.2	.22
100	7.8	.29
200	8.0	.65
300	8.4	0.83
400	8.6	1.10
500	8.7	1.41
600	8.9	1.58
700	9.0	1.72





Venkatesan et al.

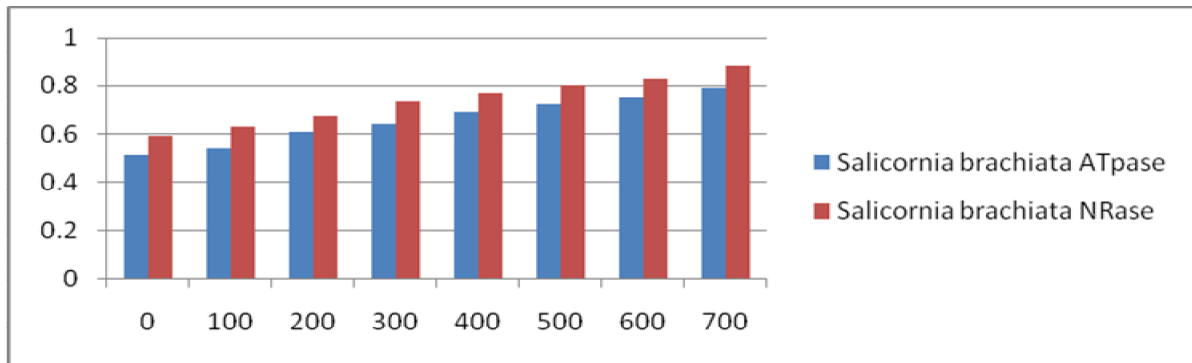

Fig .1. Effect of NaCl on ATPase activity and NRase activity in shoot of *Salicornia brachiata* at 120<sup>th</sup> day after treatment

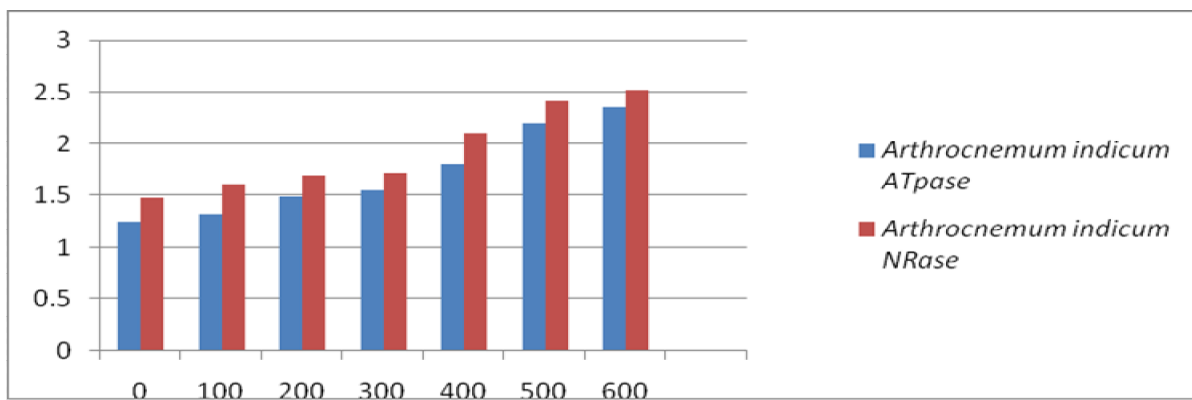

Fig.2. Effect of NaCl on ATPase activity and NRase activity in shoot of *Arthrocnemum indicum* at 120<sup>th</sup> day after treatment





## An Evaluation of Effectiveness and Efficiency of Health Management Information System (HMIS) in Australia Primary Health Care System: A Knowledge Translation Based Approach

Bhagyalakshmi Rajaram<sup>1\*</sup> and S.Manimaran<sup>2</sup>

<sup>1</sup>Associate Professor, Department of Management Studies, PSNA College of Engineering & Technology, Dindigul, Tamilnadu, India

<sup>2</sup>Head, Department of Management Studies, PSNA College of Engineering & Technology, Dindigul, Tamilnadu, India

Received: 20 Dec 2019

Revised: 24 Jan 2020

Accepted: 27 Feb 2020

### \*Address for Correspondence

#### Bhagyalakshmi Rajaram

Associate Professor,

Department of Management Studies,

PSNA College of Engineering & Technology,

Dindigul, Tamilnadu, India

Email: yakibha.ram@gmail.com



This is an Open Access Journal / article distributed under the terms of the **Creative Commons Attribution License** (CC BY-NC-ND 3.0) which permits unrestricted use, distribution, and reproduction in any medium, provided the original work is properly cited. All rights reserved.

### ABSTRACT

A Health Care Data is sharing of information from one health service provider to another through the development of National Primary Health Care Data. Data asset is being implemented in Australia during May 2018 federal budget. It sustains the reporting of data to health care indicators to understanding the patient outcomes and to get opinion from the health centers. The data files are uploaded to check the pre defined polices and the data owner may submit the correct file to Australian Institute of Health and Welfare (AIHW) to use analysis or publication. Health industry has a significant role in Information System/Technology field. This manuscript will elaborate on how the Information System (IS) implemented in the organization must be sufficiently high quality and the use of the system fulfill the need of all interested parties.

**Keywords:** Health Care, patient, Australia, Information System, Data, provider, HMIS, AIHW.

### INTRODUCTION

A health care today involves a considerable sharing of information from one physician, technician and clinic to any other health service providers. Therefore it is ideal to implement and adopt an Information System/Technology such as HMIS to connect them electronically and to become widespread. This ultimately provides benefits for patients





**Bhagalakshmi Rajaram and Manimaran**

(like Patient Identification number can be used anywhere), doctors (like records maintained online), staff nurses (like ward inventory, discharge summary etc).

Primary Health Care data unit through the development of National Primary Health Care data asset is being implemented in Australia during May 2018 federal budget. This data quality will sustain the reporting of major primary health care indicators, answers in a perfect understanding of patient outcomes, from opinion on diagnosing, method of treatment and path of experiences within the healthcare schemes. Data files are uploaded from the master information records, checked against pre-defined policies and a error report is made available to the supplier, usually in a fraction of seconds promptly. This can be frequently repeated several times as essential for the data owner to be satisfied with the accuracy of their data. The data owner may then submit the correct file to Australia Institute of Health and Welfare (AIHW) to use in analysis or publication. It is clear that HMIS will incorporate a paradigm shift in health removing manual records and transferring it into electronic information, standardization of health system and process, real time monitoring of hospitals performance, development of good communication and transformation of data through the complex structure of health departments.

The Australia Institute of Health and Welfare (AIHW) through Primary Health Care Advisory Group (PHCAG) Mission (NRHM) place a great emphasis on a well performing HMIS. Therefore it would be vital to carry out a project to strengthen the HMIS with a new approach that will promote:-

- Efficiency in all aspects of the system
- The supply of quality information on timely bases for different users
- This will enhance the whole process of strengthening HMIS
- Good working relationship with different partners

Health Industry has a significant role in Information System field, even though health industry has not yet received much attention in IS research, and the one of the important area of research in Information System is Technology evaluation and strengthening. The IS implemented in the organization must be of sufficiently high quality that use of the system fulfill the need of all interested parties.

**OBJECTIVES**

The overall objective of the proposed project is to improve and strengthen the HMIS and information usage at all levels of health information delivery system in Australia. Most importantly, to the best of our knowledge, there has been no application of technology acceptance and evaluation focused on the HMIS usage by individual health department workers. Thus applying a program of technology effectiveness evaluation and strengthening in HMIS contest is important and necessary in order to promote usage of the HMIS in rural health care system. Therefore the objective of this research is

- To investigate the HMIS effectiveness and acceptance level of users by applying HMISTAM.
- To improve and strengthen the HMIS and information usage at all levels and thereby ensure sustainability of the HMIS
- To ensure that the HMIS provides and disseminate quality essential indicators such as completeness and timeliness

**METHODOLOGY**

The type of research design to be considered in this study is descriptive study which portrays the characteristics of a particular employee's involved in Health Management Information System of AIHW. This project begins with the research about the user's acceptance and adoption towards the already existing technology and establishing various



**Bhagyalakshmi Rajaram and Manimaran**

programs to strengthen HMIS. The project will be organized in integrated but two semi-independent modules called "HMIS Programs" (HMISP), which enables the management of cost, tasks, deliverables and milestones – all according to timeline. The first HMISP1 is labeled HMIS strengthening and represents the core area of HMIS program and entails the improvement of HMIS effectiveness and its roll-out to 1/3<sup>rd</sup> of the AIHW during 3 years. The second HMISP2 is labeled HMIS capacity development creating a training scheme that would support the roll-out, based on an initial Human Resource assessment (staff and training needs).

**Target population and sample size to be covered**

The present project pertains to the AIHW sample of the study. It is decided to target those respondents who are directly or indirectly involved in the collection and processing of HMIS data in AIHW.

**Method of Data Collection**

The data collection on the research topic using the questionnaire and interview techniques will be done after selecting 14 Health Unit as the clusters under study and the stratified random sampling of blocks in each district, the Joint directors of health services and Deputy Directorate of AIHW would be approached for their assistance and help in the collection of data for the present investigation. 30 per cent of health workers (ranging from pharmacist, doctors, ANM, CHN, Lab technicians etc.) each may be randomly selected from the health units associated in these blocks and rapport will be established through personal contacts. At the district level a Health Metrics Network (HMN) a framework will be developed with to collect the data with the aim to strengthen HMIS. The HMN goal is to increase availability and use of timely, reliable health information, through coordinated investment in HMIS. In order to ensure the HMIS sustainability the HMIS program will focus on developing capacity within the AIHW in all aspects of management of HMIS data collection, analysis and dissemination.

**Sources of the data**

In order to ensure that a comprehensive list of items is included, an extensive review of previous work may be conducted. To ensure reliability while performing the research constructs, this research will try to choose those items that had been validated in literature reviews and previous research.

**Reference period of the data to be covered :- 2011 to 2018**

The key outcome of the project is seen to be information use at Sub centre (SUB), Community Health Centre (CHC), Primary Health Centre (PHC) and District level. This will be obtained through the comprehensive tool for assessing the level of information use during 2011 to 2013.

**Method of processing and analyzing**

All measurement items internal consistency reliabilities are processed based on Cronbach's alphas and another internal consistency measure, for the survey, is the inter-item correlation values. A Correlation analysis is a unique approach of establishing construct legitimacy validity for this research other than discriminate validity. Correlation analysis assesses the degree to which two measures of the same concept are correlated. High correlations indicate that the scale is measuring its intended concept (Hair, Black, Babin, Anerson & Tatham 2006). Content validity for this research using Kaiser-Mayer-Olkin may prove that the distribution of values is adequate for conducting Confirmatory Factor.

**Analysis.**

Based on the hypothesis and evaluation requirement of the HMIS Weighted Least Square Regression, Comparative Analysis like Paired sample t – test, Wilcoxon matched-pairs signed-ranks test, ANOV, Chi- square test and Multiple Regression Analysis, One way ANOVA, Multiple Discriminant Analysis and Confirmatory Factor Analysis will be applied. After the data has been processed, the first HMIS Program1 starts with developing and implementing a "tool kit" for the management based on the analysis on data collected for the management of data at district level



**Bhagalakshmi Rajaram and Manimaran**

with revision in indicators. And the second HMIS Program<sup>2</sup> will be processed through the development of “best practices” in selected health regions. Integrating computer based system at facility level (ERP) in the HMIS will also be explored in HMISP<sup>2</sup>, Specifically data quality, using information for action and user friendly HMIS guideline booklet for SUB, CHC, PHC and District staffs.

**Expected benefits**

The evaluation will examine the relevance and effectiveness of the interventions while addressing the proposed objectives. In addition, the evaluation will exercise a convert in the likelihood of continuing the project in future. If top management at the health department understand and utilizes this information to proactively design interventions (e.g. training) targeted at populations of users that may be less inclined to use the HMIS in their work in order to prepare health service providers to gain more knowledge and experience of using HMIS, not only will this help Health staffs to have better health information technology practice, personal development and quality of health services or working life, but it will also help the Australian Government to achieve the National Rural Health Mission goals and ‘Health For All’ strategy. This research methodology has seemed to be made at the right moment and in the right place to the best of its style. It is expected that key findings especially the HMIS Technology Acceptance Model will help in supporting AIHW and National policies especially the policy to provide ‘Health for all’ and Successful implementation of HMIS in all the states of Australia.

**Limitation of the study**

The results of this study were valuable because this research is pertained to be drawn upon a wide range of theoretical viewpoints and comprised a rather large sample size which covers major districts where the HMIS has been successfully implemented within all locations of Australia. However, there are still some limitations for this study. As such, no research study can claim to be prescriptive and the final verdict above the phenomenon investigated upon. The findings of the present piece of research do suffer from unavoidable limitations arising out of constraints of human and material resources and the time at the disposal of the researcher. Besides, the scope of the findings may be limited to the area chosen, tools used, methodology employed, design followed and ultimately the approach utilized for analysis and interpretation of data. These would also be subject to the delimitations envisaged at the planning stage.

**REFERENCES**

1. Ann Dadich, Hosseinzadeh H, “Healthcare reform: implications for knowledge translation in primary care”, BMC health services research 13 (1), pp 490, 2013.
2. Emily Callander, Sarah Larkins and Lisa Corscadden, “Variations in out-of-pocket costs for primary care services across Australia: a regional analysis”, Australian Journal of primary health, Vol 23 (4), pp 379 – 385.
3. Irene Ngune, Moyez Jiwa, Ann Dadich, Jaco Lotriet, Deepa Sriram, “Effective recruitment strategies in primary care research: a systematic review”, Quality in primary care, Volume 20 (2), 2013.
4. Janna Anneke Fitzgerald and Ann Dadich, “Using Visual Analytics to Improve Hospital Scheduling and Patient Flow”, Journal of theoretical and applied electronic commerce research, Volume 4 (2), pp. 20 – 30, 2009.
5. Louise K. SchaperGraham, Pervan P, “ICT and OTs: A model of information and communication technology acceptance and utilisation by occupational therapists”, International Journal of Medical Informatics, Volume 76, pp s212 – s221, 2007





## An Updated Review on Nanostructured Lipid Carrier of Non-Steroidal Anti-Inflammatory Drugs for Antiarthritic Delivery

Jenny G<sup>1\*</sup>, Killimozhi D<sup>2</sup> and Selvamuthukumar S<sup>2</sup>

<sup>1</sup>Research Scholar, Department of Pharmacy, Annamalai University, Chidambaram, Tamil Nadu, India.

<sup>2</sup>Associate Professor, Department of Pharmacy, Annamalai University, Chidambaram, Tamil Nadu, India.

Received: 18 Jan 2020

Revised: 20 Feb 2020

Accepted: 25 Mar 2020

### \*Address for Correspondence

#### Jenny G

Research Scholar,  
Department of Pharmacy,  
Annamalai University,  
Chidambaram, Tamil Nadu, India.  
Email: jennyip.1986@gmail.com



This is an Open Access Journal / article distributed under the terms of the **Creative Commons Attribution License** (CC BY-NC-ND 3.0) which permits unrestricted use, distribution, and reproduction in any medium, provided the original work is properly cited. All rights reserved.

### ABSTRACT

Rheumatoid arthritis (RA) is a chronic, inflammatory joint disease of autoimmune disease. Non-steroidal anti-inflammatory drugs (NSAIDs) are the first line drugs and afford symptomatic relief in pain, swelling, morning stiffness, immobility of RA. The conventional formulations of the NSAIDs are associated with the limitations like poor bioavailability, and non-disease specific so that development of novel delivery for the NSAIDs is important. Many of the researchers are reported the novel drug delivery of NSAIDs and also some of the review papers were available in literature of novel drug delivery of NSAIDs. Apart from this summarizing review on nanostructured lipid carriers for NSAIDs, in addition to this review is focused on Novel nanostructured lipid carriers on NSAIDs for antiarthritic delivery.

**Key Words:** Rheumatoid arthritis, nanoparticles, NDDS, Particle size, Zeta potential.

### INTRODUCTION

Rheumatoid arthritis (RA) is a chronic, inflammatory joint disease of autoimmune nature characterized by autoantibodies to immunoglobulin G (IgG; that is, rheumatoid factor) and citrullinated proteins (that is, anti-citrullinated protein antibodies). If insufficiently treated, RA can lead to accumulating joint damage and irreversible disability (1, 2, 3). RA is a heterogeneous disease, with variable clinical presentation and pathogenetic mechanisms involved between individuals with the same formal diagnosis or across different disease stages. RA is widely prevalent throughout the world. The overall worldwide prevalence is 0.8% and steadily increases to 5% in women over the age of 70. RA is two to three times more common in women compared to men. In India the prevalence has



**Jenny et al.**

been estimated to be 0.7%. Non-steroidal anti-inflammatory drugs (NSAIDs) are the first line drugs and afford symptomatic relief in pain, swelling, morning stiffness, immobility of RA (4, 5). The conventional formulations of the NSAIDs are associated with the limitations like poor bioavailability, and non-disease specific so that development of novel delivery for the NSAIDs is important (6). Many of the researchers are reported the novel drug delivery of NSAIDs and also some of the review papers were available in literature of novel drug delivery of NSAIDs. But there is summarizing review on nanostructured lipid carriers for NSAIDs, so that this review is focused on Novel nanostructured lipid carriers on NSAIDs for antiarthritic delivery.

**Non-steroidal anti-inflammatory drugs**

There are now more than 50 different NSAIDs on the global market. These drugs provide symptomatic relief from pain and swelling in chronic joint disease such as occurs in osteo- and rheumatoid arthritis, as well as in more acute inflammatory conditions such as fractures, sprains, sports and other soft tissue injuries. Several NSAIDs are available over-the-counter and they are widely used for other types of minor aches and pains. There are many different NSAID formulations available, including tablets, injections and gels. NSAIDs, their primary pharmacology are related to their shared ability to inhibit the fatty acid COX enzyme, thereby inhibiting the production of prostaglandins and thromboxanes. There are two common isoforms of this enzyme, COX-1 and COX-2. There may also be other COX enzymes that can generate prostaglandins but these have not been completely characterised. While COX-1 and COX-2 are closely related (> 60% sequence identity) and catalyse the same reaction, it is clear that there are important differences between the expression and role of these two isoforms. Some important NSAIDs are aspirin, ibuprofen, naproxen, indometacin, piroxicam and paracetamol. Newer agents with more selective inhibition of COX-2 (and thus fewer adverse effects on the gastrointestinal tract) include celecoxib and etoricoxib (7).

**Limitations for Conventional dosage form of NSAIDs**

The conventional formulations of the NSAIDs are associated with the limitations like poor bioavailability, and non-disease specific, poor solubility and non-target specific.

**Importance of novel drug delivery systems**

It implies for selective and effective localization of pharmacologically active moiety at predetermined (preselected) target in therapeutic concentration, while restricting its access to non-target normal cells (8,9). The colloidal drug delivery systems such as liposomes, niosomes, nanoparticles enhances the bioavailability of drugs. In general, these colloidal carrier systems have the nanometric size range, in this size range the liver cannot uptake the drug from the delivery system and are not metabolized by the liver. Hence, the drug will be circulated in the blood levels for prolonged period of time and delivers the drug at constant time which will reduce the toxicity. This may be achieved by using carrier systems, where reliance is placed on exploiting both intrinsic pathway that these carriers follow, and the bioprotection that they can offer to drugs during transit through the body (10, 11).

**Nanostructured Lipid Carriers**

NLCs, as a new drug delivery system, appeared in the late 1990s. This delivery system involves the modification of SLNs and a mixture of solid and liquid lipids prepared by heating and cooling crystallization. Compared to SLNs, the advantages of NLCs are as follows: a disordered crystal structure, which can help prevent leakage of the drug load and providing higher drug payload (12, 13). NLC can be loaded with hydrophobic or hydrophilic drugs with a wide range of drug-loading properties; the carrier material is biodegradable and exhibits low in vivo toxicity. NLCs can also be surface-modified. The carrier exhibits a certain organizational targeting pattern. The physical and



**Jenny et al.**

chemical properties of the NLC particles are stable. NLCs are designed by controlling the blending of solid lipids with liquid oil, prompting uncommon nanostructures in the matrix (14,15).

**Importance of NLCs**

NLCs are higher ratio of surface area to volume, show improved pharmacokinetics and bio distribution of therapeutic agents and it minimize toxicity by their preferential accumulation at the target site. And these are having the important aspects such as site specific action, increasing half-life for clearance, increasing specificity for receptor, enhanced therapeutic Effect and improved bioavailability (16).

**Various types of NLCs**

Based on structural, the NLCs are classified into three types such as disordered NLC, amorphous NLC and multiple NLC. The Imperfect NLCs are crystal lattice/matrix structure with high drug pay loading, the amorphous NLCs are amorphous matrix structure with moderate drug loading and multiple NLCs are solid lipid matrix structure with high drug pay loading (17, 18).

**NLC development methods**

The researchers has reported various preparation methods of NLCs such as hot high pressure homogenization, cold high pressure homogenization, emulsification ultrasonication method, solvent diffusion method, solvent emulsification evaporation method, microemulsion method, ultrasonic method and melt emulsification method. For these methods the basic ingredients are used to develop the NLCs like active pharmaceutical ingredient (Raw drug), Lipid phase, and surfactants and some of the researchers have used polymers for sustained and target action (19, 20, 21).

**Characterization of NLCs**

The characterization techniques are measuring the structural properties, surface charge and morphology of particle size. The carrier drug interaction, charge determination, chemical analysis of surface, drug stability, nanoparticle dispersion stability, particle size and distribution are commonly used characteristic parameters for NLCs. For this concern differential scanning calorimetry, laser doppler anemometry, zeta potentiometer, static secondary ion mass spectrometry, bioassay of drug extracted from nanoparticles chemical analysis of drug, critical flocculation temperature, atomic force microscopy, laser defractometry, photon correlation spectroscopy, scanning electron microscopy, transmission electron microscopy and X-ray photoelectron spectroscopy were used by the researchers (22, 23, 24).

**NSAIDs loaded NLCs for antiarthritic delivery**

The NSAIDs are commonly used for the management of pain and swelling in chronic joint disease such as occurs in osteo- and rheumatoid arthritis. Many of the researchers/scientists have reported the NLCs formulations of NSAIDs for antiarthritic delivery which is listed out in the Table 1.

**CONCLUSION**

NLCs are the one of novel delivery system and this review summarizes the NSAIDs loaded in NLCs. Future this review is useful for the researchers to find out the literature of NSAIDs loaded NLCs.



**Jenny et al.****REFERENCES**

1. Konig MF et al. Aggregatibacter actinomycetemcomitans-induced hypercitrullination links periodontal infection to autoimmunity in rheumatoid arthritis. *Sci. Transl Med.* 2016; 8: 176-369.
2. Pianta A et al., Two rheumatoid arthritis-specific autoantigens correlate microbial immunity with autoimmune responses in joints. *J. Clin. Invest.* 2017; 127: 2946–2956.
3. Verschueren P et al. Methotrexate in combination with other DMARDs is not superior to methotrexate alone for remission induction with moderate-to-high-dose glucocorticoid bridging in early rheumatoid arthritis after 16 weeks of treatment: the Care RA trial. *Ann. Rheum. Dis.* 2015; 74: 27-34.
4. Gopalsatheeskumar K, Komala S, Soundarya R, Parthiban S, Divya Bharathi B, Elango S. Review on Emulgel Formulations with Non-Steroidal Anti-inflammatory Drugs For Topical Administration. *Pharma Science Monitor: An International Journal of Pharmaceutical Sciences.* 2017; 8(1): 238-254.
5. Saravanan J, Neethu Devasia, Gopalsatheeskumar K, Sanish Devan V, Thanga Kokila K, Sanjay M. Anti-Inflammatory, Antipyretic And Antibacterial Study of Kabasura kudineer choornam. *International Journal of Current Advanced Research.* 2018; 7(2):9992-9997.
6. Gopalsatheeskumar K, Komala S, Mahalakshmi M. An Overview on Polymeric Nanoparticles used in the treatment of Diabetes Mellitus. *PharmaTutor.* 2017; 5(12):40-46.
7. H P Rang, M M Dale, J M Ritter, R J Flower and G Henderson. Rang and Dale's Pharmacology 7th Edition. Elsevier publication. 2007; 357-359.
8. Sanvicens N, Marco MP. Multifunctional nanoparticles—properties and prospects for their use in human medicine. *Trends in biotechnology.* 2008;26(8):425-33.
9. Khang G, Kim SW, Cho JC, Rhee JM, Yoon SC, Lee HB. Preparation and characterization of poly (3-hydroxybutyrate-co-3-hydroxyvalerate) microspheres for the sustained release of 5-fluorouracil. *Bio-medical materials and engineering.* 2001;11(2):89-103.
10. Goyal P, Goyal K, Kumar SV, Singh AJ, Katare OP, Mishra DN. Liposomal drug delivery systems—clinical applications. *Acta Pharm.* 2005;55(1):1-25.
11. Xu X, Chen X, Ma PA, Wang X, Jing X. The release behavior of doxorubicin hydrochloride from medicated fibers prepared by emulsion-electrospinning. *European Journal of Pharmaceutics and Biopharmaceutics.* 2008;70(1):165-70.
12. Lancelot AST, Serrano JL. Nanostructured liquid–crystalline particles for drug delivery. *Expert Opin. Drug Deliv.* 2014; 11:547–564.
13. Pardeike J, Hommoss A, Muller RH. Lipid nanoparticles (SLN, NLC) in cosmetic and pharmaceutical dermal products. *Int. J. Pharm.* 2009; 366:170–184.
14. Liu CH, Wu CT. Optimization of nanostructured lipid carriers for lutein delivery. *Colloid Surf A.* 2010; 353:149–156.
15. Zhang WL, Gu X, Bai H, Yang RH et al., Nanostructured lipid carriers constituted from high-density lipoprotein components for delivery of a lipophilic cardiovascular drug. *Int. J. Pharm.* 2010; 391:313–321.
16. Alexis F, Rhee JW, Richie JP, Radovic-Moreno AF, Langer R, Farokhzad OC. New frontiers in nanotechnology for cancer treatment. *Urol Oncol.* 2008; 26:74–85.
17. Muller RA, Mder K, Gohla S. Solid lipid nanoparticles (SLN) for controlled drug delivery - a review of the state of the art. *Eur. J. Pharm. Biopharm.* 2000; 50:161-177.
18. Shidhaye SS, Vaidya R, Sutar S, Patwardhan A, Kadam VJ. Solid lipid nanoparticles and nanostructured lipid carriers- Innovative generations of solid lipid carriers. *Curr. Drug Deliv.* 2008; 5:324-331.
19. Westesen K, Bunjes H, Koch MHJ. Physicochemical characterisation of lipid nanoparticles and evaluation of their drug loading capacity and sustained release potential. *J Control Release.* 1997; 48:223–236.
20. El-Helw AR, Fahmy UA. Improvement of fluvastatin bioavailability by loading on nanostructured lipid carriers. *Int. J. Nanomed.* 2015; 10:5797–5804.





**Jenny et al.**

21. Shah NV, Seth AK, Balaraman R, Aundhia C, Maheshwari RA, Parmar GR, Nanostructured lipid carriers for oral bioavailability enhancement of raloxifene: design and in vivo study. *J. Adv. Res.* 2016; 7:423–434.
22. Zheng M, Falkeborg, Zheng Y, Yang T. Formulation and characterization of nanostructured lipid carriers containing a mixed lipids core. *Colloids Surf. A: Physicochem. Eng. Asp.* 2013; 430:76–84.
23. Jores K, Mehnert W, Drechsler M, Bunjes H. Investigations on the structure of solid lipid nanoparticles (SLN) and oil-loaded solid lipid nanoparticles by photon correlation spectroscopy, field-flow fractionation and transmission electron microscopy. *J Control Release.* 2004; 95(2):217–227.
24. Fang JY, Fang CL, Liu CH, Su YH. Lipid nanoparticles as vehicles for topical psoralen delivery: solid lipid nanoparticles (SLN) versus nanostructured lipid carriers (NLC). *Eur. J. Pharm. Biopharm.* 2008; 70(2):633–640.
25. Vishal RR, Dhaval AS, Rutesh HD. Systematic implementation of quality by design (QbD) to develop NSAID-loaded nanostructured lipid carriers for ocular application: preformulation screening studies and statistical hybrid-design for optimization of variables. *Drug Development and Industrial Pharmacy.* 2020:1-13.
26. Naglakshmi S, Shanmuganathan S, Sandhya K, Anbarasan B. Design, Development and Characterization of Nano Structured Lipid Carrier for Topical Delivery of Aceclofenac. *Indian Journal of Pharmaceutical Education and Research.* 2018; 52(4):581-586.
27. Dalia AG. Nano-lipid particles of naproxen for topical application: In vitro / in vivo study. *Journal of Innovations in Pharmaceutical and Biological Sciences.* 2019; 6(1):31-36.
28. Atul AP, Praveen DC. Development and evaluation of Nanostructured Lipid Carrier (NLC) based topical delivery of an anti-inflammatory drug. *Journal of pharmacy research.* 2013; 7:677-685.
29. Blanka SS, Kozma G, Kukovecz A et al., Development of ibuprofen-loaded nanostructured lipid carrier-based gels: characterization and investigation of in vitro and in vivo penetration through the skin. *International Journal of Nanomedicine.* 2016; 11:1201–1212.
30. Gonullu et al. Formulation and characterization of solid lipid nanoparticles, nanostructured lipid carriers and nanoemulsion of lornoxicam for transdermal delivery, *Acta Pharm.* 2015; 65: 1–13.
31. Widyaningrum I, Hariyadi DM, Hendradi E. Anti-Inflammatory Evaluation of NLC (Nanostructured Lipid Carriers) Meloxicam In-Vivo. *International Journal of Drug Delivery Technology* 2017; 7(4); 327-331.
32. Viviane AG, Ligia NMR, Ana CSA. Improved efficacy of naproxenloaded NLC for temporomandibular joint administration. *Scientific Reports.* 2019; 9:11160

**Table 1. NSAIDs loaded NLCs for antiarthritic delivery**

Name of the drug	Lipid	Polymer	Surfactant used	Method of preparation	Author
Ibuprofen	DynasanVR 114 Precirol VRATO 5 ImwitorVR 900K GelucireVR 50/13 MiglyolVR 840 MiglyolVR 812 CaptexVR 355 CaptexVR 200P	-	KolliphorVR P188 KolliphorVR EL KolliphorVR HS15 KolliphorVR RH40 KolliphorVR PS80	Melt emulsification and Ultrasonication technique	Vishalet al., (25)
Aceclofenac	Phospholipon 90 H Stearic acid Oleic acid	Carbopol 940 P	Tween 80	Ultra sonication or High Speed Homogenization method	Naglakshmiet al., (26)
Naproxen	Compritol® ATO 888, Miglyol® 812, lecithin	Carbopol 971P NF	Poloxamer 188 Sodium Lauryl Sulfate	High shear homogenizer	Dalia et al., (27)







**Jenny et al.**

Aceclofenac	Compritol 888 ATO- PEG-8 Miglyol 812	-	Polysorbate 80	Melt Ultrasonication and High speed homogenization	Atul <i>et al.</i> , (28)
Ibuprofen	Witepsol E85 Miglyol 812	-	Lutrol F68	Hot High-pressure homogenization method	Blankaet <i>et al.</i> , (29)
Lornoxicam	Compritol® 888 ATO and Lanette® O Oleic acid	-	Pluronic® F68	High pressure Homogenization technique	Gonullu <i>et al.</i> , (30)
Meloxicam	Monostearin Miglyol 808	-	Tween 80	Emulsification	Widyaningrumet <i>et al.</i> , (31)
naproxen	Cetyl palmitate Capric/caprylic Triglycerides	-	Pluronic® F68	Emulsification- sonication method	Vivianeet <i>et al.</i> , (32)





## Controlled Synthesis of ZnO Materials: Nanorods to Thin Films

Suchismita Acharya<sup>1</sup>, Sachindra N Sarangi<sup>2</sup> and Susanta Kumar Biswal<sup>1\*</sup>

<sup>1</sup>Department of Chemistry, School of Applied Sciences, Centurion University of Technology and Management, Odisha, India

<sup>2</sup>Institute of Physics, Bhubaneswar, Odisha, India

Received: 18 Jan 2019

Revised: 22 Feb 2020

Accepted: 25 Mar 2020

### \*Address for Correspondence

**Susanta Kumar Biswal**

Department of Chemistry,  
School of Applied Sciences,  
Centurion University of Technology and Management,  
Odisha, India

Email: dr.skbiswal@cutm.ac.in



This is an Open Access Journal / article distributed under the terms of the **Creative Commons Attribution License** (CC BY-NC-ND 3.0) which permits unrestricted use, distribution, and reproduction in any medium, provided the original work is properly cited. All rights reserved.

### ABSTRACT

In this report, we have adopted a simple approach to prepare ZnO nanostructures on a Si- substrate using zinc nitrate ( $Zn(NO_3)_2 \cdot 6H_2O$ ) and hexamethylenetetramine (HMT) ( $(CH_2)_6N_4$ ) salts as starting materials. The effect of precursor variation on the morphology and crystalline characteristics of the ZnO nanostructures are investigated by using X-ray diffraction (XRD) and field emission scanning electron microscopy (FESEM) techniques. The FESEM image of the different samples showed that by varying the precursor concentration, the morphology of ZnO nanostructures can be tuned from nanorods morphology to microstructure like thin films. Similarly, XRD results show that the prepared ZnO nanostructures exhibit hexagonal wurtzite structure and modified structural properties by varying the precursor concentration. Hence, the growth mechanism suggests, the variance in the precursor concentration, results in various nucleation habits, which induce the formation of ZnO compound semiconductor with different morphologies and structures.

**Key Words:** ZnO Nano rods, Hydrothermal technique, FESEM, Lattice deformation.

### INTRODUCTION

The huge interests in preparation of one-dimensional semiconductor nanostructures such as nanorods, nanowires, nanosheets, and nanotubes have attracted much attention due to their unique optoelectronic properties which is useful for developing diverse applications [1-9]. Zinc oxide (ZnO) has been widely studied since 1935 [1], due to its different morphology and various applications in the field of optoelectronics[2], photo detector[3], photo catalysis[8], sensors[4] and nanotechnology [2-6]. In addition to that, ZnO nanomaterial exhibit novel biomedical applications as



**Suchismita Acharya et al.**

well as environmental application for the societal benefits [6, 7]. Zinc oxide is a low-cost n-type semiconductor with a wide direct band gap of 3.4 eV at room temperature belonging to the group of the II–VI semiconductors [8]. Also, ZnO has a large exciton binding energy of 60 meV which makes it useful in lasing actions that are based on exciton energy [8]. ZnO exists in three polymorphs such as wurtzite, zinc blende, and rock salt phase. Out of all the three, the wurtzite structure seems to be the most stable at room temperature and in ambient pressure, with Zn and O atoms forming separate hexagonal close-packed (hcp) sub lattice, where every atom has a tetragonal coordination [9].

Regarding its synthesis, both physical and chemical deposition techniques like, laser ablation [10], hydrothermal methods [11], electrochemical depositions [12], sol–gel method [13], chemical vapor deposition [14], thermal decomposition [15], and combustion method [16,17] are employed for the deposition of ZnO materials on different substrates. However, many solution-phase methods have been used to synthesize ZnO nanostructures because of their popular chemical procedure and it attributed to the simplicity of solution-phase synthesis, which is carried out at ambient or slightly elevated temperature. Among many solution-phase methods, hydrothermal growth technique is found to be a simple and cost-effective technique for preparing ZnO nanorods [7,11]. In the present work, ZnO nanorods were prepared by hydrothermal growth technique and the effect of precursor concentration on the morphology and crystalline structure of the ZnO nanostructures have been investigated.

## EXPERIMENTAL

Si (100) wafers were used as substrates for the synthesis of ZnO compound semiconductor via hydrothermal technique. Prior to the deposition, the wafers were dipped for 1 min into aqua regia to remove native oxide. Then the samples were ultrasonically cleaned with acetone, ethanol, and deionized water for 5 min respectively. Finally the wafers were rinsed with de-ionized water and then dried in ambient. The synthesis was carried out by varying the precursor concentrations from 10mM to 500mM, keeping the other synthesis parameters constant. Equimolar, Zinc nitrate ( $\text{Zn}(\text{NO}_3)_2 \cdot 6\text{H}_2\text{O}$ ) and hexamethylenetetramine (HMT) ( $(\text{CH}_2)_6\text{N}_4$ ) salts were dissolved in aqueous deionized (DI) water solution to form a 100 mL solution. Then from the above, 50 mL solution were transferred to a glass beaker of 100 mL capacity. The cleaned substrates were dipped in the solution mixture and placed in an oil bath. The glass beaker was covered with an aluminum foil and kept in an electric oven at 90 °C for 3 h for 10mM concentration and 6hr for 500 mM concentrations respectively. After the required growth, the samples were subsequently removed from the bottle, rinsed in DI water and dried in air at 60 °C for several hours. The sample for 10 mM concentration designated as S1 and the sample for 500 mM concentration designated as S2. The morphology and structural properties of samples were investigated by field-emission scanning electron microscopy (FESEM), and a X-ray spectrometer (Philips X'Pert) for X-ray diffraction (XRD) measurement where X-ray diffractometer equipped with a monochromatic  $\text{CuK}_\alpha$  radiation source (1.54178Å ).

## RESULTS AND DISCUSSION

### Preparation of ZnO Nanorods and thin films

Zinc nitrate ( $\text{Zn}(\text{NO}_3)_2 \cdot 6\text{H}_2\text{O}$ ) was used as precursor and hexamethylenetetramine (HMT) ( $(\text{CH}_2)_6\text{N}_4$ ) as surfactant for ZnO growth. The precursor solution was prepared by dissolving equimolar concentrations (10 mM and 500 mM) of zinc nitrate and HMT in deionized water under vigorous stirring for 15 minute. Then, the silicon substrates were immersed in this solution at 90 °C for 3h and 6h for Sample S1 and Sample S2 respectively. It was observed that a white ZnO precipitated at the flask bottom. Finally, the samples were thoroughly washed with deionized water and allowed to dry. The reaction mechanisms proposed for the hydrothermal synthesis is already reported by S. N. Sarangi and coworkers [7]. The corresponding chemical reaction for this particular hydrothermal synthesis is as follows





Suchismita Acharya et al.

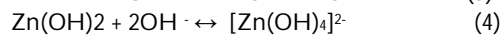
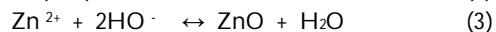
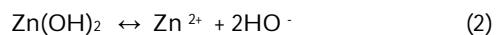
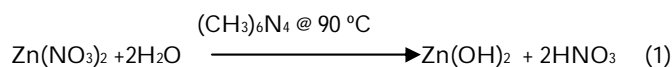

In the above reaction,  $\text{Zn}^{2+}$  ions are combined with  $\text{OH}^\cdot$  radicals in the aqueous solution to form a  $\text{Zn}(\text{OH})_2$  colloid through the reaction  $\text{Zn}^{2+} + 2\text{OH}^\cdot \rightarrow \text{Zn}(\text{OH})_2$ . Later, in the hydrothermal process, the  $\text{Zn}(\text{OH})_2$  is separated into  $\text{Zn}^{2+}$  ions and  $\text{OH}^\cdot$  radicals according to reaction (2). Then, ZnO nuclei are formed.

### Mechanism for the growth of ZnO nanorods and its transformation to thin films

HMT plays a very important role in producing different morphology in ZnO nanostructures. During the ZnO nanostructure growth, reaction of  $\text{Zn}(\text{NO}_3)_2$  and HMT produces  $\text{OH}^-$  anions as shown in the chemical equation 2. The  $\text{OH}^-$  concentration can control the formation process of new  $[\text{Zn}(\text{OH})_4]^{2-}$  ions and suppress/ enhance the crystal growth along a particular crystallographic direction. It is known that the hexagonal ZnO crystal has both polar and nonpolar faces. The polar faces with surface dipoles are thermodynamically less stable than nonpolar faces; often undergo rearrangement to reduce their surface energy [18]. The preferential adsorption leads to different growth rates of planes, that is,  $V(0001) > V\{10\bar{1}1\} > V\{10\bar{1}0\} > V\{10\bar{1}1\} > V(000\bar{1})$  [19]. Hence, in the absence of structure modifiers under hydrothermal condition, the (0001) polar plane is energetically unfavorable and has a faster growth rate than other planes. In our case, HMT, being a non-ionic tertiary amine derivative and a nonpolar chelating agent, preferentially attaches to the nonpolar facets of the ZnO crystal, thereby exposing only the (001) plane for the growth. Usually, preferential growth of ZnO occurs along the [0002] direction in case of seed deposited substrates or on lattice matched substrates. In our case, we have taken a Si substrate without seed layer deposition. The mechanism for the growth of ZnO nanorods and its transformation to thin films is as follows. Initially the ZnO nanorods grown on Si substrates for 3 hours represented as S1 as shown in figure 1. With increasing precursor concentration from 10 mM to 500 mM, the growth of ZnO nanorods continues and the nanorod's growth fused together to form thin film structure. With increasing the precursor concentration, the nanorods are extend radially from the center and grow as thick nanorods and cover the Si substrate as thin film form shown in Figure 1. At the same time, when the precursor concentration increased by 50 times, i.e 500 mM, due to large number of nucleation sites the nanorod's growth overlap with each other and the average growth rate increased by many fold, thus produces a thin film rather than a nanorod morphology as shown in step II of the schematic figure 1

### Structural properties

To investigate the effect of the precursor concentration on the crystalline structure of ZnO nanorods, XRD analysis was performed on ZnO grown on Si substrate by hydrothermal technique. It can be seen from Figure 2, that all patterns have peaks at 31.76, 34.40, 36.24, 47.56, 56.64, 62.86, 66.87, 68.09 and 69.70 corresponding to the (100), (002), (101), (102), (110), (103), (200), (112) and (201) planes of ZnO, respectively, which correspond to the typical diffraction peaks of hexagonal wurtzite ZnO (JCPDS No. 36-1451). The presence of several peaks in the XRD reveals that the nanorods are polycrystalline. No impurity phases were observed in XRD spectra. Hence, the use of zinc nitrate and HMT precursors seems to be an effective way to grow ZnO nanorods by hydrothermal technique without inducing any kind of undesired compounds.

This is important to observe (002) peak for ZnO material because it decides the orientation, phases and disorder in crystal of the ZnO sample. We have made the Gaussian fittings of (002) peak (figure not shown here) of samples S1



**Suchismita Acharya et al.**

and  $S_2$  and calculated the structural parameters such as inter-planer spacing, lattice constants  $a$ ,  $c$ ,  $c/a$  ratio, unit cell volume, bond length and strain which are presented in Table 1.

The full-width-half-maximum (FWHM) values of (0 0 2) peak of ZnO nanorods samples (Sample  $S_1$ ) on Si substrate are found to be more than the sample thin film sample (Sample  $S_2$ ). This result suggests that as the precursor concentration increases, the FWHM value of (0 0 2) peak decreases, thus improves the crystallinity quality of ZnO. The reasonably narrow FWHM widths for ZnO thin film (sample  $S_2$ ) demonstrate the high crystal quality of ZnO sample obtained by hydrothermal technique on Si substrates. The (002) peak positions have a slight shift towards lower angles, generating a deformation in original structure, hence there is overall change in all the structural parameter such as inter-planer spacing, lattice constants  $a$ ,  $c$ ,  $c/a$  ratio, unit cell volume, bond length and strain as shown in Table 1.

**Morphological Studies by FESEM**

The morphology of the hydrothermally grown ZnO materials were investigated by FESEM. Figure 3 shows the FESEM images of ZnO materials and the effects of precursor concentration on the morphology of ZnO. Figure 3 (a) shows the morphology of sample  $S_1$  where the precursor concentration was chosen to be 10 mM. The growth pattern shows well-arranged ZnO nanorods uniformly distributed over the substrate surface. The length of the nanorods found to be varied from 2.0  $\mu\text{m}$  to 6.0  $\mu\text{m}$  approximately. However the diameter of the ZnO nanorods is in the range of 70 to 90 nm. Similarly, Figure 3 (b) shows the morphology of sample  $S_2$  where the precursor concentration was chosen to be 500 mM. It is clearly evidenced from the FESEM micrograph of Figure 3 (b), that there is no nanorod present in the sample and the morphology of this sample clearly depicts ZnO material in thin film form. Macroscopic structures of ZnO are present on the Si substrate. This result suggests that, with increasing the precursor concentration, the rate of growth of ZnO nanorods increases on Si substrate.

This is because, the availability of more nucleation center on the surface of the substrate due to increased precursor concentration. The effect of precursor concentration on morphology and size are clearly visible in these set of samples. A model has been proposed to understand the growth of ZnO nanorods to ZnO thin film, which is schematically represented in Figure 1 and discussed in previous section. Thus, the precursor concentration is a key factor in the hydrothermal technique to achieve controlled ZnO nanostructure growth.

**CONCLUSION**

In conclusion, controllable synthesis of ZnO material is possible using hydrothermal technique by varying the precursor concentration. The structural and morphological properties of ZnO materials fabricated by varying the precursor concentration using hydrothermal technique have been investigated. The FESEM studies showed that ZnO morphology can be tuned from nanorods to thin film form by varying the precursor concentration. The structural analysis has confirmed the improvements in crystallinity in high precursor concentration sample i.e in thin film form. The results obtained in this study demonstrate that the structure and morphology of ZnO can be tailored by tuning the precursor concentration. This result suggests that the variance in the precursor concentration, results in various nucleation habits, induces the formation of ZnO compound semiconductor with different morphologies and structures which can be used for opto-electronic device applications.

**REFERENCES**

1. Bunn, C W, Phys. Soc. London, 47(1935) 835
2. Chen H, Zhao L, Wang G & Fang W, Clean Techn Environ Policy, 19(2017) 1335
3. Zhao Y, Yu N, Dong X & Yan H, Materials Research Innovations, 21 (2017) 447





## Suchismita Acharya et al.

4. Husham M, Nizar M, Paiman H, S Abuelsamen, A A Farhat, O F Al-Dulami, A A, Sensor Act. A 263 (2017) 166
5. M Jeem, L Zhang, J Ishioka, T Shibayama, Iwasaki, T Kato and S Watanabe, Nano Lett. 17(2017) 2088
6. Tiwari, S. et al. Zinc oxide nanorods functionalized paper for protein preconcentration in biodiagnostics. *Sci. Rep.* 7, 43905; doi: 10.1038/srep43905 (2017)
7. [Sarangi, S. N., Nozaki, S. Sahu, S. N., ZnO nanorod-based non-enzymatic optical glucose biosensor, *J. Biomed. Nanotech.* 11 (6), 988-996 (2015)
8. Prasad, N., Saipavitra V. M. M., Swaminathan, H., Thangaraj, P., Viswanathan, M. R., Balasubramanian, K., Microstress, strain, band gap tuning and photocatalytic properties of thermally annealed and Cu-doped ZnO nanoparticles, *Appl. Phys. A* 122, 590- (2016)
9. J.M. Azpiroz, E. Mosconi, F.D. Angelis, Modeling ZnS and ZnO nanostructures: structural, electronic, and optical properties. *J. Phys. Chem. C* 115, 25219–25226 (2011).
10. Scarisoreanu, N., Metai, D. G., Dinescu, G., Epurescu, G., Ghica, C., Nistor, L. C., Dinescu, M., Properties of ZnO thin films prepared by radio-frequency plasma beam assisted laser ablation. *Appl. Surf. Sci.* 247, 518–525 (2005).
11. Ni, Y. H., Wei, X. W., Hong, J. M., Ye, Y., Hydrothermal synthesis and optical properties of ZnO nanorods. *Mater. Sci. Eng., B, Solid State Mater. Adv. Technol* 121, 42–47 (2005).
12. Chang, S., Yoon, S. O., Park, H. J., Sakai, A., Luminescence properties of Zn nanowires prepared by electrochemical etching. *Mater. Lett.* 53, 432–436 (2002).
13. Ristiac, M., Musiac, S., Ivanda, M., Popoviac, S., Sol-gel synthesis and characterization of nanocrystalline ZnO powders. *J. Alloys Compd.* 397, L1–L4 (2005)
14. Wu, J.J., Liu, S.C., Low-temperature growth of well-aligned ZnO nanorods by chemical vapor deposition. *Adv. Mater.* 14, 215–218 (2002).
15. Wang, R. C., Tsai, C. C., Efficient synthesis of ZnO nanoparticles, nanowalls, and nanowires by thermal decomposition of zinc acetate at a low temperature. *Appl. Phys. A.* 94, 241–245 (2009)
16. Lamas, D. G., Lascalea, G.E., Walsoc, N.E., Synthesis and characterization of nanocrystalline powders for partially stabilized zirconia ceramics. *J. Eur. Ceram. Soc.* 18, 1217–1221 (1998).
17. Badhuri, S., Badhuri, S. B., Enhanced low temperature toughness of Al<sub>2</sub>O<sub>3</sub>-ZrO<sub>2</sub> nano/nano composites. *Nanostruct. Mater.* 8, 755–763 (1997).
18. Guo, W., Liu, T., Huang L., Zhang H., Zhou, Q., Zeng W., HMT assisted hydrothermal synthesis of various ZnO nanostructures: Structure, growth and gas sensor properties, *Physica E*, 44, 680-685 (2011).
19. W. Li, E. Shi, W. Zhong, Z. Yin, Growth mechanism and growth habit of oxide crystals, *Journal of Crystal Growth*, 203 186-196 (1999).
20. O. Lupan, T. Pauporte, L. Chow, B. Viana, F. Pelle, L.K. Ono, B. Roldan Cuenya, H. Heinrich, Effects of annealing on properties of ZnO thin films prepared by electrochemical deposition in chloride medium, *Appl. Surf. Sci.* 256, 1895 (2010).
21. Salhotra K R & Chattopadhyay R, *Indian J Chem Technol*, 52 (1982)317.

Table 1. Structural parameters of the ZnO materials

Sample	Interplanar spacing, d(Å)	Lattice constants(Å) a,c		c/a ratio	Unit cell Volume, V(Å <sup>3</sup> )	Bond length, L(Å)	Strain(%)
S <sub>1</sub>	2.604291021	3.006005074	5.206553515	1.732050807	41.83067934	1.880144325	0.01063225125
S <sub>2</sub>	2.594434708	2.994628416	5.186848566	1.732050807	40.28165849	1.873028649	0.8932076834





Suchismita Acharya et al.

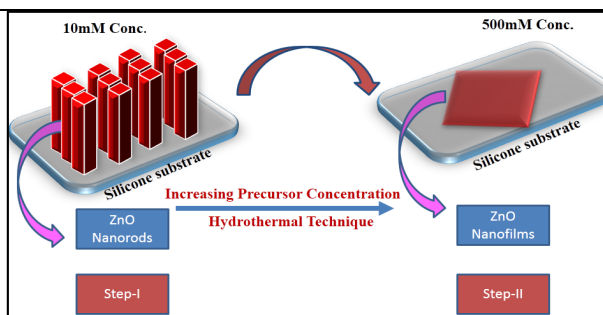

Figure 1 Schematic diagram for transformation of ZnO Nano rods to ZnO thin films

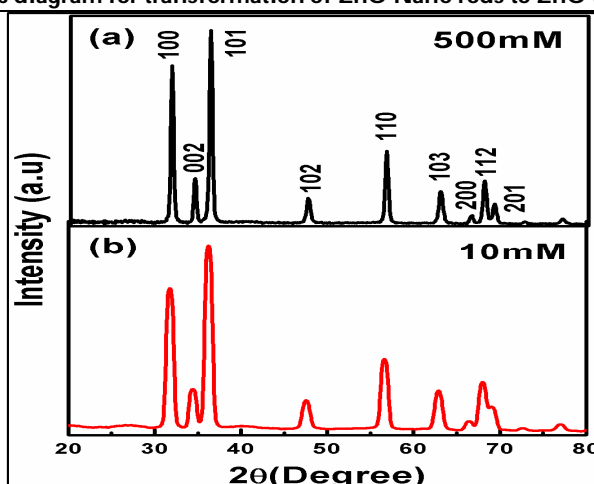

Figure 2 XRD patterns of ZnO material deposited on Si substrate (a) 500 mM concentration (sample S<sub>2</sub>), (b) 10 mM concentration (sample S<sub>1</sub>).

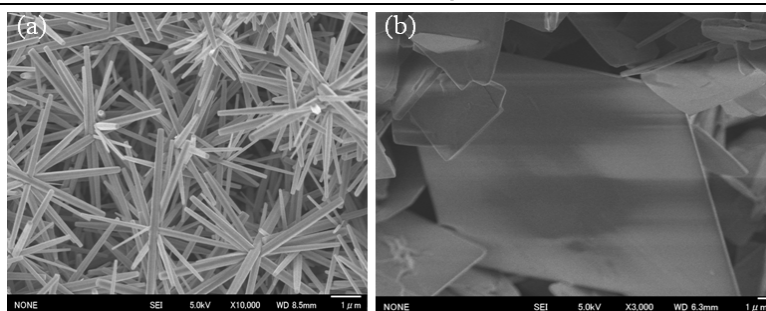

Figure 3 The FESEM image of ZnO nanostructures (a) Sample S<sub>1</sub> (10mM concentration), (b) Sample S<sub>2</sub>, (500mM) concentration.





## COVID-19 and SARS-CoV-2: Molecular Genetics Perspectives

Muhammed Elayadeth-Meethal<sup>1\*</sup>, SHYJU OLLAKKOTT<sup>2</sup> and Godavarma Girish Varma<sup>3</sup>

<sup>1</sup>Assistant Professor, Kerala Veterinary and Animal Sciences University, Pookode, Wayanad, Kerala, India.

<sup>2</sup>Ph.D Scholar, Kerala Veterinary and Animal Sciences University, Pookode, Wayanad, Kerala, India.

<sup>3</sup>Faculty Dean (Poultry Science), Kerala Veterinary and Animal Sciences University, Pookode, Wayanad, Kerala, India.

Received: 19 Jan 2020

Revised: 21 Feb 2020

Accepted: 25 Mar 2020

### \*Address for Correspondence

#### Muhammed Elayadeth-Meethal

Assistant Professor,

Kerala Veterinary and Animal Sciences University,

Pookode, Wayanad, Kerala, India.

Email: dremmuhammed@gmail.com.



This is an Open Access Journal / article distributed under the terms of the **Creative Commons Attribution License** (CC BY-NC-ND 3.0) which permits unrestricted use, distribution, and reproduction in any medium, provided the original work is properly cited. All rights reserved.

### ABSTRACT

Corona virus disease-19 (COVID-19) is a zoonotic viral disease caused by severe acute respiratory syndrome corona virus (SARS-CoV-2), which was first reported from Wuhan, Hubei province, in China in December 2019. The source of virus is believed to be from bats and the intermediate host is pangolins (ant eaters). The SARS-CoV-2 genome is fully sequenced and genome data are available now. Recent molecular studies on the three corona viruses- SARS-CoV, MERS-CoV(Middle East Respiratory Syndrome Corona virus), and SARS-CoV-2 can shed light on the mechanisms of COVID-19 infection, which could help the world to identify therapeutic target molecules, formulate control measures, and adopt appropriate preventive measures including development of vaccine(s).

**Key Words:** COVID-19, SARS-CoV-2, MERS-CoV, genome, infection, sequence.

### INTRODUCTION

Severe acute respiratory syndrome (SARS) was reported from China in 2002-2003 and the causative corona virus was named SARS corona virus (SARS-CoV). Later in 2011, a corona virus named MERS-CoV was reported to cause Middle East Respiratory Syndrome (MERS) in Saudi Arabia. A third time in the *late 2019*, the latest corona epidemic was reported from Wuhan, Hubei province, in China, from a sea food and live animal market, whence the disease was named corona virus disease-19 (COVID-19) by the World Health Organisation (WHO). Subsequently, WHO declared COVID-19 as a Public Health Emergency of International Concern (PHEIC) on 31<sup>st</sup> of January 2020 directing an international coordinated response across the globe. The International Virus Classification Commission named the causative virus of COVID-19 as SARS-CoV-2. of late, WHO declared COVID-19 as pandemic, which

18751





**Muhammed Elayadeth-Meethal et al.**

means that the virus can spread across the globe rapidly so that it may affect people worldwide and cautioned countries to take measures to contain the spread of COVID-19 (Heymann and Shindo, 2020; Lu *et al.*, 2020)

**Molecular genetics of SARS-CoV-2**

Corona viruses are usual inhabitants in wild as well as domestic animals. The viruses become infective and cause diseases under two conditions: (1) when virulence (capacity of virus to produce disease) of viruses increases under suitable conditions such as changed climate; and/or (2), when the immunity of the host (animals/humans) decreases under conditions of stress. This article addresses the current knowledge on mechanistic processes at molecular level leading to increase in virulence of viruses and factors leading to immune deficits making humans more susceptible to the corona virus attack.

All viruses, in general, are obligatory intracellular, in the sense that a virus to survive it needs to be inside a living cell. Outside the living cell, viruses survive only for a short while. Entry of corona viruses into the living cell is through the mucosa of respiratory or digestive tract or eyes. That is how disinfecting hands (by frequent washing and use of sanitizer) and avoidance of hands touching mouth, nose and eyes help to prevent entry of viruses in to the body. Viruses possess either RNA or DNA as their genetic material. Unlike other cells, viruses neither contain a nucleus nor cell organelles like mitochondria or ribosomes. Instead, they use the host cellular machineries for their normal metabolic processes. For example, when corona virus infects human cells they use the human cellular organelles and ultimately kill the cells.

SARS-CoV-2 has a single stranded positive stranded RNA genome, which is of 26-32kb in size (Figure 1). The genome size of SARS-CoV and MERS-CoV is 27.9 kb and 30.1 kb, respectively. Among the four corona virus genera of  $\alpha$ ,  $\beta$ ,  $\gamma$  and  $\delta$ ,  $\alpha$  (HCoV-229E and NL63) and  $\beta$  (MERS-CoV, SARS-CoV, HCoV-OC43 and HCoV-HKU1) corona viruses infect humans. The efforts to identify the source of SARS-CoV-2 are in progress and maximum genetic identity of the SARS-CoV-2 (99%) was with the corona virus in pangolins (ant eaters)(Zeng *et al.*, 2020; Prompetchara *et al.*, 2020).

The genome of corona virus encodes non-structural proteins (NSPs) that forms viral replicase transcriptase complex (that controls viral multiplication inside human cells) and four structural proteins, viz, spike (S), envelope (E), nucleocapsid (N) and membrane (M) proteins. NSPs coded by two-third of the viral genome, control replication of viruses (virus multiplication) and formation of proteins once they enter inside the human cells (viral transcription). The remaining one-third of the viral genome codes structural proteins, which has a pivotal role in the entry of viruses in to the cells.

The virus enters in to the human cells through the receptors located on the surface of the human cells. The cell surface receptors on human cells are unique for each virus and this determines the susceptibility of various organs in the human body for viral attack. The genome sequence analysis using spike protein determining entry of receptor-binding domain (RBD) shows that for both SARs-CoV and SARs-CoV-2, the predominant cell surface receptor is angiotensin-converting enzyme 2 (ACE-2), where as, for MERS-CoV the predominant receptor is dipeptidyl peptidase 4 (DPP4, also known as CD26). The basic reproductive number ( $R_0$ ), the average number of individual getting infected from an infected individual, in COVID-19 ranges from 2.2 to 2.6, with a doubling time of 6.4 days. Continued transmission is predicted if  $R_0$  is greater than 1. The  $R_0$  value of SARS-COV and MERS-COV was less than 1 and 1.4 - 2.5, respectively. The higher  $R_0$  of SARS-COV-2 implies more contagious nature of the virus and the potential of SARS-CoV-2 as a pandemic, as we see now [5]. An interdisciplinary research into the molecular mechanisms and better understanding of the receptor binding and viral entry mechanisms will help to understand how SARS-CoV-2 virus causes disease conditions in humans and how we can prevent the viral entry.



**Muhammed Elayadeth-Meethal et al.****Molecular genetics of COVID-19**

As mentioned earlier, the structural envelope spike glycoprotein (S) is the significant determinant of viral entry in to the human cells. ACE-2 receptors are ubiquitous in a wide range of wild and domestic animal species except in rats and mice. In the lungs, the ACE-2 receptors are predominantly seen in a specific subset of cells in the lung alveoli- the alveolar type 2 cells. The immune cells in the lung- monocytes and macrophages also express ACE-2 receptors, but only a few cells have ACE-2. Recent studies show additional mechanisms of viral entry into susceptible individuals. The S protein binds to the ACE-2 and TMPRSS-2 receptors in case of SARS-COV-2, to the ACE-2 and CD209L (L-SIGN, a C-type lectin) in case of SARS-CoV and, to the DPP4 in MERS-CoV. Other mechanisms identified for the corona virus entry in to the human cells are through S protein activation mediated either through proteolytic cleavage of S protein or through furin-mediated activation. Moreover, the affinity of SARS-CoV-2 to ACE-2 is also different- SARS-CoV-2 has 10-20 fold more affinity to ACE-2 compared to SARS-CoV, another reason for high virulence of SARS-CoV-2. After receptor binding, viral envelope protein fuses with plasma membrane (the outer membrane of human cells) enabling the entry of virus in to the cells. After viral entry in to the cell, viral genome is released in to the cytoplasm of the cell, starts multiplying (replication) and produce structural and non-structural proteins (translation). The new viruses thus formed fuses with the plasma membrane of the cells and virus infection of the cell is complete resulting in disease condition-COVID-19, in infected individual (Ahmed *et al.*, 2020).

The SARS-CoV infection reported in 2003 was successfully contained, thanks to the concerted efforts of scientists, public and policy makers in making aware the whole population regarding the threats of a pandemic. After the SARS outbreak in 2003, there were only a few follow-on disease reports mainly due to accidental out breaks in research laboratories. After 2003, there had been no new reports of SARS-CoV and hence SARS-CoV was considered eliminated from human populations. The origin of SARS-CoV, MERS-CoV and SARS-CoV-2 is common bats; and the intermediate hosts harboring the viruses are palm civets; camels and pangolins, respectively. SARS-CoV causing contagious pneumonia like infection in healthcare personals originated from the live animal market in Guangdong province in China (Wu *et al.*, 2020).

The mean incubation period of SARS-COV-2 is 6.4 days within a range of 2.1 to 11.1 days and the primary mode of infection is human-to-human transmission through close contact. The SARS-COV-2 gets entry in to the body through exhaled air or through cough or sneeze. The international travel of infected people mainly caused spread of the disease across the nations. SARS-CoV-2 has a different epidemiology and it behaves like other corona viruses that cause common cold. They predominantly replicate at the upper respiratory tract initially without causing any abrupt severe symptoms. Hence, infected individuals carry significant viral load at the upper respiratory tract while they carry on usual day-to-day activities, allowing others to get infected.

The pandemic spread of SARS-CoV -2 is mainly due to its transmission through asymptomatic carriers (persons who do not show any symptoms while they carry virus). In a study among 277 COVID-19 confirmed individuals in Wuhan, 200 of them had never visited Wuhan market and were not in close contact with severely ill patients. Conversely, SARS-CoV mainly spread through persons who were severely ill, and thus the control of infection was relatively easy compared to SARS-CoV-2. Moreover, mathematical disease modeling of SARS-CoV shows transmission rate of 5% during asymptomatic period. Interestingly, SARS-CoV-2 also has affinity towards lower respiratory tract causing all the three common clinical symptoms of corona virus infection- common cold, mild pneumonia and acute severe pneumonia with acute respiratory distress syndrome (ARDS). Thus, although the case fatality rate of SARS-CoV-2 is low (2.8% compared to SARS-CoV (9.14%)and MERS-CoV (34.4%), SARS-CoV-2 is more disruptive than SARS-CoVand MERS-CoV due to its chances of rapid spread and the ability to produce life threatening respiratory syndrome in affected individuals (Rabi *et al.*, 2020).

The Scientific and Technical Advisory Group for Infectious Hazards (STAG-IH), under WHO regularly assess the risk of COVID-19 in various countries. The current understanding on COVID-19 is that SARS-CoV-2 causes mild to



**Muhammed Elayadeth-Meethal et al.**

severe attacks in infected individuals producing life threatening ailments to the old and people with other illnesses such as diabetes and pulmonary disease pointing that immune-competent individuals have a lower risk of severe symptoms.

In a study among 752 COVID-19 patients in China, fever (86-90%), cough (49.1-51%), fatigue (25.2-27.1%), discharge of sputum (20- 23.1%) and headache (9.8-11.1%) were the common symptoms. The mortality rate also varied in different regions: 4.6% in Wuhan, 1.9% in Beijing, and 0.9% in Shanghai. In the same study the researchers also compared the results in 14,117 normal controls. There exists phenomenon of lymphocyte depletion (PLD)-a compensatory mechanism in patients with low immunity such as in HIV patients or in those under chemotherapy. The age related increased susceptibility to COVID-19 is explained through differential lymphocyte levels. As the age increased, the natural killer (NK) cells were elevated and the CD4, CD8 and B-lymphocytes decreased suggesting an age-dependent decline of B and T cell immune function. This clinical case study also revealed the reference ranges of individuals at high risk of COVID-19 infection- CD3+, CD4+ and CD8+ lymphocytes less than 900, 500 and 300 cells/mm, respectively. Study also recommended screening for lymphocyte subsets as soon as individuals are diagnosed as COVID-19 positive in order to assess the severity of viral attack (Zenet *et al.*, 2020). Quantitative real time polymerase chain reaction (qRT-PCR) helps clinicians to assay lymphocyte subsets and assess severity of illness.

When an individual comes in close contact with SARS-CoV-2 source (virus carriers like bats or pangolins or with infected individuals) the human cells respond to the entry of viruses through antigen processing cells (APCs) called major histocompatibility complex (MHC) or human leucocytic antigens (HLAs) and virus-specific cytotoxic T lymphocytes (CTLs). The polymorphisms (gene sequence differences) in HLA genes explain individual differences in susceptibility of SARS-CoV-2 in different populations. Gene polymorphisms in mannose-binding lectin (MBL) also cause differences in corona virus susceptibility among different individuals and populations. The innate immune cells identify viral entry in to the cells by recognizing pathogen associated molecular patterns (PAMPS). For COVID-19, TLR3 and TLR7, the RNA receptors in the endosomes, and RIG-I/MDA5, RNA sensor in the cytosol, recognize either positive stranded RNA of SARS-CoV-2 or intermediary double stranded RNA generated from SARS-CoV-2 at its replication stage. Subsequently virus enters in the nucleus of the infected cell; and this is called nuclear translocation. This results in the induction of type 1 interferon and other pro-inflammatory cytokines, thus sparking the first line of defense against viral attack in the cells. This type 1 interferon mediated response trigger JAK-STAT pathway through interferon AR (IFNAR) and phosphorylate JAK1 and STAT1 using JAK1 and TYK2 kinases. Activated JAK-STAT form complex with IRF 9 and this activated complex stimulate expression of interferon-stimulated genes (ISGs) with the help of interferon stimulated response element (ISRE) (Li *et al.*, 2020). If this interferon mediated response is successful, viral replication and dissemination is suppressed at an early stage; it means that the human host cells won the battle and the individual escaped from viral attack.

It was found that SARS-CoV and MERS-CoV mount suppression of type 1 interferon response leading to severe clinical manifestations. For example, SARS-CoV degrade MAVS and TRAF3/6-the RNA sensor adaptor molecules while, MERS-CoV repress modification of histones; both these potentially inhibit type 1 interferon response (Li *et al.*, 2020). Many COVID-19 therapeutic experimental protocols under trial target this interferon mediated disease defense pathway where timing of intervention is found to be the most important factor in breaking the chain of disease progression.

Subsequent to antigen presentation, another line of defense against SARS-CoV-2 infection is the B cell and T cell mediated humoral and cellular immunity. In severe acute viral infections, there is a typical pattern of immunoglobulin G and M (IgG and IgM) profile, where IgM is present only for a few weeks; IgG lasts longer. IgG is S and M specific in SARS-CoV infection. T cell proliferation, delayed type hypersensitivity (DTH) response and production of interferon- $\gamma$  (IFN- $\gamma$ ) persist for years in recovered individuals. The plasma of the recovered individuals may contain an abundance of immune molecules; this is the basis of convalescent serum therapy, also



**Muhammed Elayadeth-Meethal et al.**

called donated plasma therapy. As we can imagine, the action of convalescent serum would be transient, and may require repeated infusions for getting a prolonged effect (Li *et al.*, 2020).

Acute respiratory distress syndrome is the major cause of death in SARS-CoV-2 mediated through cytokine storm (that is, uncontrolled release of pro-inflammatory cytokines such as interferons and interleukins). The cytokine storm induced progression of disease severity is common for SARS, MERS and COVID-19. In general, the cytokine flux initiates virus-induced sepsis and lung inflammation causing shock, organ failure, respiratory failure and potentially, death. However, some of the interferons have protective effect against SARS-CoV and MERS-CoV (for example IFN- $\alpha$  and IFN- $\beta$ ), which are strong therapeutic target molecules as SARS-CoV-2 specific drugs.

For diagnosis, the first clue is obtained from the epidemiological history and clinical manifestations. The auxiliary diagnostic methods include detection of viral nucleic acid (the single stranded SARS-CoV-2 RNA, either through qRT-PCR or nucleic acid sequencing), CT scan, immunoglobulin assay (point-of-care testing, POCT) of IgM/IgG, enzyme-linked immunosorbent assay (ELISA) and the blood culture. For qRT-PCR diagnosis of SARS-CoV-2, the Chinese Center for Disease Control and Prevention (China CDC) suggests using specific primers and probes in the open reading frame 1ab (ORF1ab) and N gene regions. Once both targets are positive, they suggest, the COVID-19 is confirmed (Nguyen *et al.*, 2020). The qRT-PCR can be done using saliva samples, which makes sample collection easy and non-invasive. CT scan images show bilateral pulmonary parenchymal ground glass and consolidative pulmonary opacity making CT scan a valuable aid for clinicians for differential diagnosis.

**Vaccines against COVID-19**

Since the immune response is identical in SARS, MERS and COVID-19, there exists a possibility of designing cross-reactive immunization against all the three human corona viruses – SARS-CoV, MERS-CoV and SARS-CoV-2. Deoxyribo nucleic acid (DNA) vaccine, viral vector vaccine, subunit vaccine, vaccine using virus like particles, live attenuated virus vaccine and formaldehyde/gamma irradiated whole virus vaccine are most promising COVID-19 vaccines. Full-length S protein or S1 that contains receptor-binding domain (RBD) is considered a good antigen, as explained in the previous sections. This vaccine can target viral attachment to the host cell preventing early infection (Ahmed *et al.*, 2020).

**Treatment against COVID-19**

Developing treatment protocols mainly target repurposing of current antiviral drugs to intervene viral entry or disease progression pathways. Long-term memory of immune cells in corona-infected individuals may also help devising therapeutic strategy against COVID-19- including the one described earlier, the convalescent serum therapy or donated plasma therapy (Li *et al.*, 2020).

**Conclusions and future strategies**

In a pandemic like COVID-19, control of spread of the disease and developing therapeutic strategy are of primary concerns. Identifying the molecular mechanisms operating at cellular level may help to develop vaccines and formulate control measures. This may also help to find therapeutic target molecules and effective drugs against the disease. Extensive viral detection and characterization of SARS-CoV-2 in different regions of the world may aid to identify genetic differences among the virus and formulate vaccines and antiviral drugs.

The big challenges we are facing such as in developing vaccine for SARS-CoV-2, or treating COVID-19 patients, identifying causes of increasing virulence of SARS-CoV-2, and understanding mechanisms of reduced immunity among animals and humans against COVID-19, cannot be solved by a single discipline alone. Emphatically, insight



**Muhammed Elayadeth-Meethal et al.**

into the holistic/stand alone approaches of the ayurvedic and several other indigenous systems have promising role in the future transdisciplinary consortium to address the impending issues across the globe, including those arising from climate change.

**Authors**

Dr. Muhammed Elayadeth-Meethal is a veterinarian turned molecular geneticist by training and works as Assistant Professor at Kerala Veterinary and Animal Sciences University. His research focuses on genetics of climate change adaptation and mitigation. He was awarded Crawford fellowship for research at University of Western Australia, Perth, Australia. He is also Rothamsted International Fellow at Rothamsted Research, UK. He can be contacted at dremmuhammed@gmail.com muhammed@kvasu.ac.in, or +91 9447409406.

SHYJU OLLAKKOTT is a Senior Medical Officer in dept. of Indian Systems of Medicine under Government of Kerala and a PhD scholar in biosciences (Molecular genetics) at Kerala Veterinary and Animal Sciences University. He can be contacted atrshyju@gmail.com or +919747552074.

Prof (Dr) Godavarma Girish Varma, is the Faculty Dean (Poultry Science) and Dean, College of Avian Sciences, Kerala Veterinary and Animal Sciences University. He has attained his Masters degree in Animal Physiology & Climatology from the Deemed University of Indian Veterinary Research Institute, Izzathnagar, U.P., India. Prof. Varma was later awarded PhD by the University of Edinburgh, UK for his research at Roslin Institute under BBSRC on "molecular characterization of 'leptin-like' gene in the chicken genome". He can be contacted at girish@kvasu.ac.in or +91 9446229673

**REFERENCES**

1. Heymann, D.L. and Shindo, N., 2020. COVID-19: what is next for public health?. *The Lancet*, 395: 542-545
2. Lu, R., Zhao, X., Li, J., Niu, P., Yang, B., Wu, H., Wang, W., Song, H., Huang, B., Zhu, N. and Bi, Y., 2020. Genomic characterisation and epidemiology of 2019 novel coronavirus: implications for virus origins and receptor binding. *The Lancet*, 395(10224), pp.565-574.
3. Zeng, Q., Li, Y.Z., Huang, G., Wu, W., Dong, S.Y. and Xu, Y., 2020. Mortality of COVID-19 is Associated with Cellular Immune Function Compared to Immune Function in Chinese Han Population. *medRxiv*.
4. Prompetchara, E., Ketloy, C. and Palaga, T., 2020. Immune responses in COVID-19 and potential vaccines: Lessons learned from SARS and MERS epidemic. *Asian Pac J Allergy Immunol*.
5. Li, X., Geng, M., Peng, Y., Meng, L. and Lu, S., 2020. Molecular immune pathogenesis and diagnosis of COVID-19. *Journal of Pharmaceutical Analysis*.
6. Ahmed, S.F., Quadeer, A.A. and McKay, M.R., 2020. Preliminary identification of potential vaccine targets for the COVID-19 coronavirus (SARS-CoV-2) based on SARS-CoV immunological studies. *Viruses*, 12: 254.
7. Wu, F., Zhao, S., Yu, B., Chen, Y.M., Wang, W., Song, Z.G., Hu, Y., Tao, Z.W., Tian, J.H., Pei, Y.Y. and Yuan, M.L., 2020. A new coronavirus associated with human respiratory disease in China. *Nature*, 579:265-269.
8. Rabi, F.A., Al Zoubi, M.S., Kasasbeh, G.A., Salameh, D.M. and Al-Nasser, A.D., 2020. SARS-CoV-2 and Coronavirus Disease 2019: What We Know So Far. *Pathogens*, 9: 231.
9. Nguyen, T., Duong Bang, D. and Wolff, A., 2020. 2019 Novel Coronavirus Disease (COVID-19): Paving the Road for Rapid Detection and Point-of-Care Diagnostics. *Micromachines*, 11: 306.
10. Li, C., Yang, Y. and Ren, L., 2020. Genetic evolution analysis of 2019 novel coronavirus and coronavirus from other species. *Infection, Genetics and Evolution*, 23: 104285.



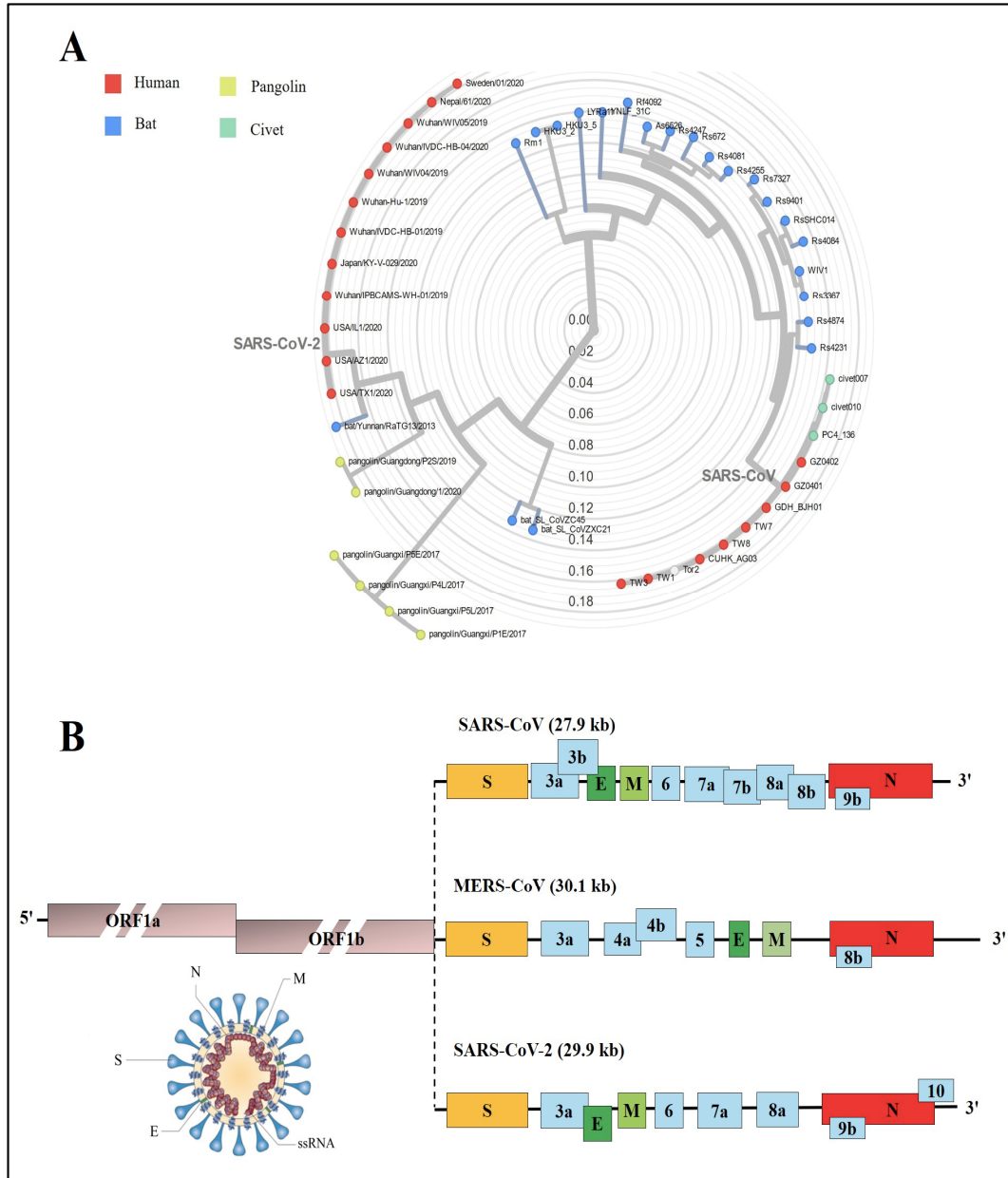

Figure 1. Molecular phylogeny and structure of recent corona viruses. A) The relationship between the SARS-CoV and SARS-CoV-2 identified from different sources. Note that the SARS-CoV-2 was more closely related to corona virus isolated from bats and pangolins (ant eaters). B) The structure of corona virus and its genome organisation. ssRNA-single strand RNA; M, N, S and E-the viral structural proteins; ORF-open reading frame; the total genome size of SARS-CoV, MERS-CoV and SARS-CoV-2 is also given (adapted from Li et al., 2020).





## Studies on Limnological Parameters of Bramhani Pond Water, Sundargarh (Odisha)

Ankita Patel and Pradip Kumar Prusty\*

Department of Zoology, School of Applied Sciences, Centurion University of Technology and Management, Odisha, India.

Received: 19 Jan 2020

Revised: 21 Feb 2020

Accepted: 25 Mar 2020

### \*Address for Correspondence

#### Pradip Kumar Prusty

Department of Zoology,  
School of Applied Sciences,  
Centurion University of Technology and Management,  
Odisha, India.

Email: pradipkumar.prusty@cutm.ac.in



This is an Open Access Journal / article distributed under the terms of the **Creative Commons Attribution License** (CC BY-NC-ND 3.0) which permits unrestricted use, distribution, and reproduction in any medium, provided the original work is properly cited. All rights reserved.

### ABSTRACT

Limnology is related to the study of fresh water ecosystem as well as their physical, chemical, geological and biological aspects of that ecosystem. Bramhani pond spread over nearly about two hectares of area at the centre of Sundargarh town, Odisha, India. The study of different physico-chemical parameters were done for about five alternative days in the month of winter from 24<sup>th</sup> December, 2019 to 2<sup>nd</sup> January, 2020. For the studvarious parameters, the sampling of water from the different sites of pond at the morning time that is 9.00 AM. The analysis of water was carried out in laboratory using the standard method of APHA-AWWA-WEF, 1999, Abbasi,1998 and by using the systronic water analyser – 371. The results of this study revealed that the physico-chemical parameters were slightly change. During the period of this study different parameters were determined that are atmospheric temperature, water temperature, colour, transparency, pH, conductivity, salinity, turbidity, total hardness, Magnesium hardness, Calcium hardness, BOD,COD,total dissolved solid, dissolved oxygen. Also study the biological species like zooplankton, fishes and birds. Correlation of the above different parameters can be obtained by simple linear regression equation of type  $Y=A+Bx$ . Due to different practises like increasing population, advance agriculture, presence of various contaminants and anthropogenic activities the water of the pond become highly polluted. Water is play a vital role in survival of human, plants, animals and microbes and also for the aquatic ecosystem surround it. Availability of good water also able to prevent the diseases and improve the water quality. This study gives idea about the present status of Bramhani pond and also determined the suitability of water for the irrigation, agriculture, fishery and mainly for drinking purpose. This present status determine by both quality and quantity of the different parameters of that pond. The value of this water is compare with WQI value and found that water of this pond is in moderate condition, suitable for various practices and quite unfit for the drinking purpose.

18758



**Ankita Patel and Pradip Kumar Prusty**

The important attributes of the water quality such as water temperature (12.52 C -19.7 C ), electrical conductivity (406 $\mu$ S/cm-411.4 $\mu$ S/cm ), salinity ( 0.256ppt-0.268ppt ), turbidity (1.214NTU), pH (6.97-7.124), dissolve oxygen (9.21mg/l-10.836mg/l), BOD (4mg/l), COD (24mg/l), Magnesium hardness (14.58mg/l), Calcium hardness (49.69mg/l ), total hardness( 184mg/l), TDS(206.6mg/l-229.2mg/l) were observed.

**Keywords:** Limnology, electrical conductivity, salinity, dissolved oxygen

**INTRODUCTION**

Water is one of the most important natural resource of the ecosystem. It fulfil the basic need of all living organisms found on earth and their growth and survival. It is generally a chemical compound that is form by the combination of the two chemical elements that is hydrogen and oxygen, also it contain many other dissolve substances. It is one of the most essential compound found is everywhere. Earth is the only planet which have 70% of water. It is also scientifically proved that life is form from the aquatic body and to determine their physical and chemical parameters are quite difficult to understand. Two hundred years ago Aristotle , gave a statement that water is one of the most important component among four fundamental component they are air, soil and fire. According to WHO it is estimated that about 97.25% water is in ocean and 2.05% found as glacier condition and also these are manage the other water bodies like lake, dam, pond etc.

Limnology is the part of environmental science that correlate the various branch of science like physics, chemistry, geology and biology. The word Limnology comes from the Greek word "Limne" means "Lake" and "logos" means "Knowledge". But in this study many other water bodies are also consider that are pond, wetland, river, stream, reservoir etc. Prof.F.A. Forel of Switzerland first coined the term "Limnology". This study include different physical, chemical parameters with the biological aspects which are mostly affected by the environmental conditions. Limnological study is beneficial for the long term goal for the various practices. Flora and fauna are not sufficient to determine the water condition so in earlier period the scientist were consider the physical and chemical parameters with biological aspects like flora and fauna and also their environmental conditions found in aquatic ecosystem. Now a days the water level become fluctuated and the density of the organisms are also decreases due to environmental pressures like degradation of habitat, overpopulation, flow modification and water pollution. So that, analysis of physical and chemical parameters of water is therefore essential (Salodia,1996). Limnological study was previously done by various scientist in various places. The variation in the physico-chemical parameters of the lake has been studied in India and abroad by Dhamija and Jain (1994), Swarnalatha (1994), Kagalouet. al;(2001), Sedamkar and Angadi (2003), Salaskar and Yeragi,(2003), Abegaz et. al;(2005), Sachidanandamurty and Yajurvedi (2006), Akin et. al;(2008), Mathur et.al;(2010), Verma et. al;(2011), Telkhade et. al;(2012), Joshi and Patel (2012), Hardikar and Acharya (2013)and Siddhartha et. al;(2013).

Measuring the physico-chemical parameters of water is the first step of management of the water body. It also help to improve the water quality and fulfil the future need in different sectors. The physico-chemical parameters are changes periodically and it also directly relate with the biological production. Planktons are very much sensitive community found in water body in floating condition and their growth and density also depend on the above parameters. Fishes and birds species are also very much affect the aquatic ecosystem. Sometimes they also depend on the water body for their food.





**Ankita Patel and Pradip Kumar Prusty**

## MATERIALS AND METHODS

Odisha situated in the east coast of India. Sundargarh is one of the district present westpartof the Odisha. Bramhani pond is the one of the oldest pond present in the centre of the Sundargarh town. The total area cover by the Bramhani pond is around two hectors. The diameter is roughly around 6 meter and the depth is approximately 3 meter. It was constructed by Raja family in the year 1952. It is one of the highly use pond by the local people for different purpose like irrigation, household work and drinking purpose.

### Sampling method and laboratory analysis

Water samples were collected in morning hours at 9.00 am from five different sampling sites of the pond during winter season that is in the month of December of each alternative days from 24<sup>th</sup> December, 2019 to 2<sup>nd</sup> January ,2020. Water samples were collected from the surface area of the pond in a clean and rinsed plastic sampling bottles and further analysis was carried out in the laboratory. The important physico-chemical parameters like pH, electrical conductivity, salinity, turbidity, total dissolve solid, BOD , COD, dissolve oxygen, total hardness , Calcium hardness , Magnesium hardness were analysed in laboratory by following method given by Welch (1952) , Trivedi et. al;(1987) and APHA-AWWA-WEF, 1999;Abbasi,1998;and by using Systronics water analyser-371 kit.

## RESULT AND DISCUSSION

The values of different physico-chemical characteristics of Bramhani pond from the five different sampling site during the time period of 24<sup>th</sup> December, 2019 to 2<sup>nd</sup> January, 2020 were noted in different tables for better analysis.

### Atmospheric temperature and water temperature

Atmospheric temperature is the most important factors that affect all the other parameters. It is varies with the climatic changes. It affects the biological communities. It affects the water temperature on which the parameters are dependent. Water temperature also depends on the concentration of carbon dioxide. Increase in temperature also influence the metabolic activities like increase microbial nutrient cycle , reproductive rate, also increase the growth rate of juvenile pf aquatic plants, micro vertebrates and fishes. During the present study, the maximum atmospheric temperature was recorded in 24<sup>th</sup> December that was 27 °C and the minimum atmospheric temperature was recorded in 26<sup>th</sup> December that was 19 °C. The water temperature was also highest in 26<sup>th</sup> December that was ±1.40 and lowest was in 30<sup>th</sup> December that was ±0.12.

### Transparency

It is directly depending on the amount of suspended organic and inorganic particles arepresent in the water body. The combine effect of colour and turbidity also very much affect with some other factors like fluctuation of weather, rainfall, plankton density, wind velocity etc. In this work the transparency was 38cm.

### pH

The pH value of water depends on the presence of Calcium carbonate and bicarbonates. The pH values of polluted water is either lower or higher than 7, it based on the nature of the pollutants. From the investigation it was noted that the pH range between 6.13 to 7.43.

### Electrical Conductivity

It is depends on the total minerals present in the water body. It is also the numerical expression of the water ability to conduct the electric current. During the investigation period the conductivity was noted range from 387 to 433.





**Ankita Patel and Pradip Kumar Prusty**

**Dissolve Oxygen**

It is the most important parameter that affects chemical as well as biological aspects of the ecosystem. These parameters also depend on the water temperature. During the research the dissolve oxygen ranges from 9.07 mg/l to 11.12mg/l.

**Salinity**

The ideal salinity range from 0.1ppt to 0.25ppt .In this pond the recorded salinity range was 0.24ppt to 0.28ppt. So here the water salinity is between the acceptable range and it also suitable for healthy fish.

**Turbidity**

It is determine by the suspension of particle present in the water interfering with scattered of light. It is generally measure by the Nephelometer. Maximum value of turbidity is due to rainfall and runoff water bringing lots of sediments from the surrounding. During the study period recorded turbidity value was 1.17 NTU to 1.26 NTU

**Total Dissolve Solid (TDS)**

It is determine by the amount of solid present in the water in dissolve condition. Maximum value of TDS was 254 mg/l and the minimum value was 201 mg/l recorded during the study period.

**Other Parameters**

**Total Hardness**

Total hardness of water is cause due to divalent cations such as Magnesium , Calcium determine due and earth metal like iron, strontium etc. Magnesium and calcium causes temporary hardness and sulphate and Chloride causes permanent hardness.The result was recorded from this study was 184mg/l. That means the hardness of Bramhani pond water is very hard for drinking purpose.

**Magnesium Hardness**

The main source of Magnesium is rocks so it is consider as one of the main element of the earth crust. It able to influence the hardness but found in fewer amounts than the amount of calcium.

**Calcium Hardness**

The main source of calcium deposition in the water is dolomite, limestone and other calcium breaking rocks. It is also main nutrient for micro -organisms and also use by molluscs. In this study the Calcium Hardness recorded was 49.69 mg/l.

**Biological Oxygen Demand(BOD)**

BOD is determine by the amount Oxygen used by the microorganisms in aerobic condition. Generally this value gives idea about the load of water pollution and efficiency of the wase water treatment. In this study the recorded BOD value was 4 mg/l. That means this results indicate that the water of this pond is slightly polluted.

**Chemical Oxygen Demand(COD)**

It determines the amount of Oxygen equivalent to the organic content of the water. It is measured by open reflux method. The recorded value of Bramhani pond water was 24 mg/l.

**Zooplankton**

These are types pf plankton found in waterbodies. Many factors like temperature, light intensity, conductivity, turbidity are affect the density of the zooplankton. In this study 15 species of Zooplankton were identified among them 4 species of Protozoa , 4 species of Rotifera , 3 species of Cladocera , 2 species of Ostracode and 2 species of Copepoda.



**Ankita Patel and Pradip Kumar Prusty****Fishes**

In the Bramhani pond water there are generally 5 dominant species of fishes were identified by their morphological characters.

**Birds**

In Bramhani pond there are generally 10 species birds were identified by their morphology. They are belonging from different family. They are able to find their food in this pond water.

**CONCLUSION**

From the present investigation, it is clear that the physico-chemical characteristics of Bramhani pond varies comparable and considerably from the other fresh water bodies. The result of this study gives idea about the water quality of the pond and also it may suitable for the primary producer and fish production due to presence of basic nutrients . Also the environmental condition suitable for that. All the physico-chemical parameters are found in the permissible limits. Hence it can be concluded that water of Bramhani pond is suitable for the various purposes like irrigation, agriculture, pisciculture and drinking purpose etc. This study also beneficial for the management and conservation of the pond and its ecosystem.

**REFERENCES**

1. Ade, P.P., Wankhede,GN.2001. Limnological studies of Amravati University Reservoirs with reference to trophic status and conservation,Ph.D.Thesis,Amravati University, Amravati.
2. Ahmed,M.andKrishnamurty, R.1990. Hydrobiologicalstudies of Woharreservoir Aurangabad (Maharashtra state),India,J.Environ.Biol.,11(3):335-343.
3. APHA (1989). Standard method for examination of water and waste water (17<sup>th</sup> End.).American Public Health Association,Washington,D.C.
4. Arjariya, A . (2003) Physicochemical profile and plankton diversity of Ranital lake, Chhatarpur, M.P. Nature Env .Polln. Techno., 2(3):327-328.
5. Basavaraja,Simpi, S. M., Hiremath,K. N. S. Murthy , K. N. Chandrashekarappa,Anil N. Patel , E.T. Puttiah, Analysis of water Quality Using Physico-Chemical Parameters Hosahalli Tank in Shimoga District , Karnataka , India, Gopal Journal of Science Frontier Research ,2011,1(3),pp31-34.
6. Bhagat S, Chauhan , SK Sagar. Impact of pollutants on water quality of river Sutlej in Nangal Area of Punjab , India, Biological Forum – An International Journal 2013;5(10):113-123.
7. Bhandri , N. S. and K . Nayal (2008)Correlation study on physicochemical parameters and quality assessment of Kosi river water , Uttarakhand, e- Journal of Chemistry , 5(2):342-346
8. Chaturbhuj,M.,Sisodia,R.,Kulshreshtha,M., and Bhatia,A.L.2004.A.Case study of the Jamwaramgarrhawetland with species reference to physico-chemical properties of water and its environs,Department of Zoology , University,respected of Rajasthan,Jaipur ,India Sethi Colony ,Jaipur , Rajasthan, India ., Journalof Hydrobiology.,pp16.
9. Dash,B. 1993.Biological nitrogen fixation in freshwater pond ecosystem with reference to hydrobiological conditions Ph.D. Thesis,O. U.A.T.,Bhubaneswar,pp.318.
10. Dubey, M.,Tiwari,A.K.,and Ujjania,N.C.2013.The study of physico-chemical properties pf Sahapura Lake, Bhopal, (India).International Journal of Advanced Research.1(8):158-164.
11. Farnaz, S. and Md. Rahmatullah (2013) Study of water quality using physico-chemical parameters of Gangasagar pond at. Darbhanga district, Bihar, India Streams Research Journal , 3(3):1-6.
12. Ishaq , F. and A. Khan (2013) Comparative assessment of physicochemical conditions and Plankton diversity of river Tons and Asan in Dehradun District of Uttarakhand . Advances in Applied Science Research , 4(2):342-355.





### Ankita Patel and Pradip Kumar Prusty

13. Jain, R.(2008) Physicochemical seasonal analysis of Singwasa reservoir Guna, M.P.(India). Journal of Environmental Research and Development, 39(1):191-197.
14. Joshi,P . S.(2011) Studies on Zooplanktons of Rajura Lake of Buldhana district , Maharashtra,India.Science Research Reporter 1(3):132-137.
15. Krishnan (2008)Investigation on hydrobiology and water quality parameters of Periyar Lake, Thekkady, Kerala, Ph.D .Thesis, Mahatma Gandhi University , Kerala.
16. ManjushaBhor ,PrakashKadave , AbhijitBhor. Water Quality Assessment of the River Godavari, At Ramkund ,Nashik , (Maharashtra), India International Journal of Engineering and Science . January 2013;2(2):64-68.
17. Mishra,s. and R. C. Panigrahy,(1996)Copepods of Bahuda estuary(Orissa),east coast of India.Indian J. Marine Sci.,25(2):98-102.
18. Pandey , B. N.,R.Siddhartha,K.D.Tanti, and A.K.Thakur (2013)Seasonal variation in zooplanktonic community in Swamp of Purnia (Bihar),India Aquatic Biology Research Sciknow Publications Ltd. ,1(1):1-9.
19. Patra, A. P., J. K. Patra , N. K. Mahapatra , S. Das and G. C. Swain (2010)Seasonal variation in physicochemical parameters of Chilika lake after opening of new mouth near Gabakunda, Orissa, India. World Journal of Fish and Marine Sciences, 2(2):109-117.
20. Sharma ,D.K. and R. P. Singh , (2012)Seasonal variations in zooplankton diversity in Tiger reservoir, Gwalior (Madhya Pradesh ) , India J.Sci. Res.,3(2):155-161.
21. Tambekar,P, Morey P, Batra RJ. Physico-chemical parameter evolution of water quality around Chandapuer District , Maharashtra , India , Journal of Chemical and Pharmaceutical Research. 2013;5(5):27-36.
22. V.K.Balai , L.L.Sharma and N.C. Ujjania,(2016) Limnological study of Jaisamand Lake (India) and its suitability for aquaculture and fisheries, International Journal of Applied And Pure Science and Agriculture. 2016;2(1):25-30

**Table 1. Atmospheric temperature and water temperature**

Date	Atmospheric temperature
24.12.2019	27
26.12.2019	19
28.12.2019	24
30.12.2019	23
2.01.2020	26

**Table 2. Other Parameters**

BOD (mg/l)	4
COD (mg/l)	24
Total Hardness(as CaCO <sub>3</sub> )(mg/l)	184
Calcium (as Ca)(mg/l)	49.69
Magnesium(as Mg)(mg/l)	14.58

**Table 3. List of Zooplankton recorded in Bramhani pond**

Protozoa	<i>Amoeba proteus</i> Muller
	<i>Arcella gibbosa</i> pennard
	<i>Colpoda aspera</i> Kahl
	<i>Paramecium caudatum</i> Ehrenb
Rotifera	<i>Asplanchna priodonta</i> Mastax
	<i>Branchionus quadridentates</i> Hermann
	<i>Filina longiseta</i> Ehrenb
	<i>Notholca cuminata</i> Goose
Cladocera	<i>Ceriodaphnia rigaudi</i> Richard
	<i>Daphnia carinata</i> King





## Ankita Patel and Pradip Kumar Prusty

	<i>Macrothrix sp.</i> Baird
Ostracoda	<i>Centrocypris sp.</i>
	<i>Stenocypris malcalmsoni</i> Brady
Copepoda	<i>Mesoclops leuckartii</i> Claus
	<i>Mesoclops hyalinus</i> Rehberg

Table 4. List of Fishes recorded in Bramhani pond

Common name	Scientific name	Order	Family
Spotted snakehead	<i>Channa punctate</i>	Anabantiformes	Channidae
Striped snakehead	<i>Channa striatus</i>	Perciformes	Channidae
Walking catfish	<i>Clarias batrachus</i>	siluriformes	Clariidae
limbing perch	<i>Anabas testudineus</i>	Perciformes	Anabantidae

Table 5. List of Birds recorded in Bramhani pond

Common Name	Scientific Name	Family
Lesser Whistling Duck	<i>Dendrocygna javanica</i>	Dendrocygnidae
Northern Pintail	<i>Anas acuta</i>	Anatidae
Cattle Egret	<i>Bubulcus ibis</i>	Ardeidae
Little Egret	<i>Egretta garzetta</i>	Ardeidae
Eurasian Coot	<i>Fulica atra</i>	Rallidae
Southern Coucal	<i>Centropus (sinensis) parroti</i>	Cuculidae
White throated Kingfisher	<i>Halcyon smyrnensis</i>	Alcedinidae
Green Bee-eater	<i>Merops orientalis</i>	Meropidae
Black Drongo	<i>Dicrurus macrocercus</i>	Dicruridae
Indian pond Heron	<i>Ardeola grayii</i>	Ardeidae

Table 6. Variation in physico-chemical parameters

Days	24.12.19		26.12.19		28.12.19		30.12.19		2.01.20	
	Mean	±S.D	Mean	±S.D	Mean	±S.D	Mean	±S.D	Mean	±S.D
Physico-chemical parameters										
Water temperature	19.7	0.438	12.52	1.408	17.08	0.132	17.56	0.12	18.2	0.509
pH	6.98	0.270	6.97	0.320	6.974	0.443	7.124	0.103	7.11	0.108
Electrical conductivity	411.4	10.287	406	13.053	410.6	13.093	409.6	2.787	410	5.549
DO	9.21	0.107	10.836	0.183	9.64	0.046	9.72	0.029	9.55	0.056
Salinity	0.266	0.014	0.256	0.013	0.268	0.026	0.262	0.011	0.26	0.014
TDS	214	3.577	208.6	6.280	206.6	1.356	221	6.131	229.2	12.655





**Ankita Patel and Pradip Kumar Prusty**

**Table 7. Co-relation of the physico-chemical parameters**

	Water Temperature	pH	Electrical conductivity	TDS	DO	Salinity
Water Temperature	1					
pH	0.329244	1				
Electrical conductivity	0.959481	0.15766	1			
TDS	0.454571	0.892467	0.243627	1		
DO	-0.99221	-0.26567	-0.98646	-0.37923	1	
Salinity	0.69345	-0.22711	0.859303	-0.25975	-0.7671	1



**Fig. 1. Bramhanipond ,Sundargarh, Odisha**

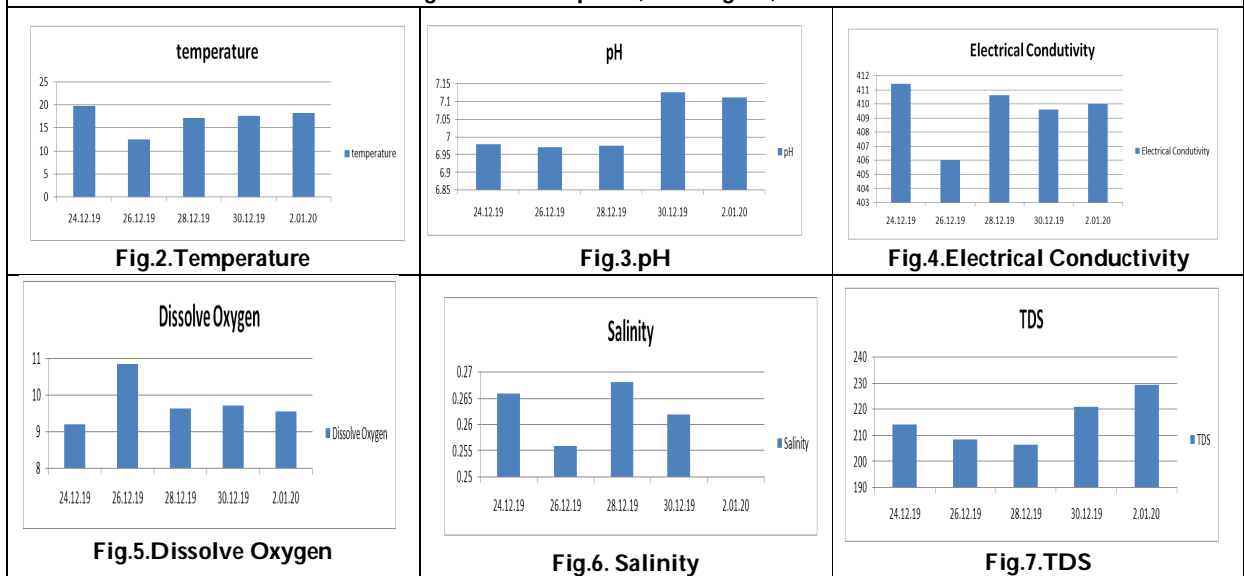



## Isolation, Identification and Screening of Enzyme Producing Bacteria from Groundnut Rhizospheric Soil Samples Collected from Idappadi Block of Salem District in Tamil Nadu, India

T.Sathya<sup>1</sup>, P.Yogeshwari<sup>1</sup>, S.Shalini<sup>1</sup>, S.Sowmiya<sup>1</sup>, K.Sri Sivambiga<sup>1</sup>, R.Surya<sup>1</sup>, S.Thilagavathi<sup>1</sup>, S. Saranya<sup>1</sup>, P.M. Ayyasamy<sup>2</sup>, R. Rajakumar<sup>3</sup> and Annadurai Sakthi Thesai<sup>1\*</sup>

<sup>1</sup>Department of Microbiology, Vivekanandha College of Arts and Sciences for Women (Autonomous), Elayampalayam, Tamil Nadu, India

<sup>2</sup>Department of Microbiology, Periyar University, Salem, Tamil Nadu, India.

<sup>3</sup>Department of Marine Biotechnology, Bharathidasan University, Tiruchirappalli, Tamil Nadu, India

Received: 21 Jan 2020

Revised: 23 Feb 2020

Accepted: 25 Mar 2020

### \*Address for Correspondence

#### Annadurai Sakthi Thesai

Department of Microbiology,

Vivekanandha College of Arts and Sciences for Women (Autonomous),

Elayampalayam, Tamil Nadu, India

Email: drsakthithesai@vicas.org



This is an Open Access Journal / article distributed under the terms of the **Creative Commons Attribution License** (CC BY-NC-ND 3.0) which permits unrestricted use, distribution, and reproduction in any medium, provided the original work is properly cited. All rights reserved.

### ABSTRACT

The use of associated plant-based, native beneficial microbes for sustainable farming is increasing worldwide acceptance as they colonize effectively under stress conditions at specific plant habitat to maximize crop productivity. In the present study, indigenous plant growth promoting bacterial isolates were isolated from the rhizospheric soil of groundnut plants aiming to investigate their enzyme producing capability. Totally 24 bacterial isolates were isolated from the two rhizospheric soil samples collected from the agricultural field. Out of twenty four bacterial isolates were 13 isolates were amylase positive, 13 isolates were protease positive, 4 isolates were phosphatase. As a result, this study revealed novel native microbes are potential for the development of groundnut plants.

**Keywords:** Groundnut, Amylase, Protease, Phosphatase, Enzyme.

### INTRODUCTION

Food security issues are growing daily as demand for cereals to increase production by 50 percent from agricultural land, which is expected to be 30% lower than today by using less water, chemical fertilizer and labor. As per capita availability of cultivated area to 0.11 ha by 2020 CE [1], in an agricultural priority country such as India, it could be negative and a threat to food security for ever-increasing world population. Among the crops producing oil, groundnut (*Arachis hypogaea* L.) is one of the major, productive crops grown all year round in India and India is a

18766



**Sathya et al.**

world leader in groundnut farming with 8 million hectares of cultivated area in the 2002-2003 periods [2]. When it is related to the global scenario, it is predicted that 20 percent of cultivable land and 33 percent of irrigated agricultural land will be affected by high salinity, which is expected to rise by 10 percent annually to impact over 50 percent of arable land by 2050 [3]. The existing unfavorable surrounding environment in agriculture (mainly abiotic stress) destabilize the structure, physiology, and expression of various plant household cell macromolecules, resulting in decreased crop production [4,5,6].

Groundnut, *Arachis hypogaea L.*, a part of the leguminous family, is an economically significant crop that is cultivated across the world in about hundred countries. The biggest contributors are, India, Nigeria, United States and other climatic tropical and subtropical countries [7]. Some existing heavy metals interacts with various enzymes i.e nitrate reductase, nitrite reductase, peroxidase, catalase, glutathione reductase, superoxide dismutase, ascorbate peroxidase, in diverse parts of groundnut plants, follow-on in reduced root, shoot length and enhance in proline, phenolic flavonoids substance and lignin biosynthesis in plant [8,9,10]. On the other hand, soil enzymes are extraordinary biomolecules that show remarkable specificity in catalyzing biological reactions, significant for both soil microorganisms and plants [11]. Further, they act as vital indices of soil fertility [12]. The widespread application of pesticides lead to interference with the normal enzyme activity of proliferating soil microorganisms and disturbing the delicate balance of soil enzymes in maintaining soil biodynamics [13,14].

The use of associated plant-based, native helpful microbes for sustainable agriculture is expanding worldwide acceptance as they colonize successfully under stress conditions at specific plant habitat to increase crop productivity. So the native microbes produce many regulators for plant growth and protect plants from adversity such as salt and metal stress [15,16,17,18]. Since bacteria live at the bottom of the trophic stage, they are very important for their survival and adaptability to any infinitesimal changes in the surrounding environment. The present study aims at screening plant growth promoting bacteria from rhizospheric soil.

## MATERIALS AND METHODS

### Sample collection

The two different soil samples were collecting from kallapalayam and kollapatty village of Idapadi, Salem district in Tamil Nadu. The latitude for Idappadi is 11.584286 and the longitude is 77.837013. The sampling sites are known to be groundnut cultivated agricultural field and sampling sites were presented in Fig.1. The soil samples about 1kg were taken from the depth of 15 cm, pooled and then sieved. Samples were transported to the laboratory, air dried and stored in sterile polyethylene bags at 4°C for further study.

### Enumeration of bacteria

One gram of soil sample was taken and mixed with 100 ml sterile distilled water and kept as aliquate with in a mechanical shaker (120 rpm) for 15 minutes for serial dilution then spread plate and pour plate technique were carried out on nutrient agar for the enumeration of bacteria species from the soil sample. Then all plates were incubated at 37°C for 24 hours. After the incubation the total numbers of bacterial colonies were counted in each plate. The plating was performed in duplicates and average was recorded. The bacterial species were isolated based on the colour, appearance and colony morphology and then isolates were stored in the nutrient agar media for further studies [19].

### Identification of bacteria

The obtained bacterial isolates were examined for Gram staining and microscopic viewing for identification of bacterial strains. Followed by the isolates were identified by performing several biochemical tests like Fermentation test, Catalase test, oxidase test, Citrate utilization test, Methyl-red test, and Voges-Proskauer test by standard methods.





**Sathya et al.****Preparation of pure culture of bacteria**

The entire morphologically different bacterial colony was picked up into inoculation loop and performed quadrant streak on nutrient agar plate. Then all plates were incubated at 37°C for 24 hour. After that individual colony was streaked on sterilized nutrient agar slant they were incubated at suitable condition. After the incubation the culture bottles were stored at 4°C for further studies.

**Screening of amylase producing bacteria (Starch iodine Test)**

Identified isolates have been screened for amylolytic activity by dot the individual isolates on 1% starch dextrose agar medium. The agar plate had been incubated 24-48 hours at 37°C. Culture plate has been flooded with iodine to define clearing zone around culture. The diameter of the clearing zone formed represents the amylolytic activity of isolated strain [20].

**Screening of protease producing bacteria**

Identified isolates have been screened for proteolytic activity by dot the individual isolates on 1% skim milk agar medium. The agar plate had been incubated 24-48 hours at 37°C. After the incubation the culture plates were for clearing zone around culture. The diameter of the clearing zone formed represents the proteolytic activity of isolated strain [21].

**Screening of Phosphatase producing bacteria**

For phosphate solubilization efficiency one loopful of pure culture of isolated individual strain was dotted on sterilized PVK agar medium separately. After that all plates were incubated at a temperature  $28^{\circ}\text{C} \pm 2^{\circ}\text{C}$  for a maximum period of 15 days. Based on the appearance of clear halo zone colonies, strains were visually assayed [22].

**RESULT AND DISCUSSION****Isolation of microorganisms in soil samples**

The total heterotrophic bacteria were estimated in soil samples collected from Idappadi block of Salem District, Tamil Nadu in India. The enumeration of bacterial count was done for the entire soil samples and isolation was carried out on the nutrient agar by spread plate technique. Colour, appearance and morphologically different bacterial colonies were observed and they were isolated. Among the two samples obtained, the soil sample 1 (Kallapalayam) contained the colonies about  $110 \times 10^4$  CFU/g. The sample 2 (Kollapatty) contains  $92 \times 10^4$  CFU/g. A total of 24 different bacterial strains were isolated from the rhizosphere soil obtained from agricultural areas. The isolated colonies were picked up from plates according to their different morphology, purified and sub-culturing respectively onto fresh nutrient agar plate using the streak plate technique. The isolated and purified bacterial strains were selected for identification. These all strains were maintained at 4°C for further studies.

**Identification of bacteria**

The isolated all bacterial strains were identified up to the generic level based on the colour, appearance and morphology according to the Bergy's Manual of Determinative Bacteriology. Fig.2 was showed that the distribution of the bacterial genera obtained in soil samples. Out of 24 bacterial strains, 52.17% was noted as *Bacillus spp.* and it was the predominant and higher in numbers among isolated strains. Then second most popular group was *Micrococcus spp.* 17.39%, followed by *Acinetobacter spp.* was 13.04%, *Azotobacter spp.* was 8.7%, *Pseudomonas spp.* was 4.35% and *Lactobacillus spp.* was 4.35%. The collected bacterial strains were isolated to pure culture on nutrient agar medium using streak plate method and incubated for 24-48 h at 37°C. The pure culture isolates were stored on nutrient agar slants as stock culture for further studies. Table.1 was showed the identification of bacterial isolates from soil samples. The higher plant root systems are connected to a large population of metabolically active microorganisms. There are higher inorganic and organic issues around the plant roots which create a unique habitat



**Sathya et al.**

around the roots for microbial species to thrive well adjacent to the root area. The population of microbes in this region would be much higher than the root-free soil, the difference may be both quantitative and qualitative [23].

### Screening of amylase producing bacteria

Out of 24 bacterial isolates 13 strains were showed the amylase activity on the starch agar plates. Amylase activity was observed from the zone of hydrolysis observed on agar surface and results presented in Fig.2. The enzyme amylase plays a crucial role in catalyzing the hydrolysis and solubilization of starch. Starch hydrolyzing enzymes are usually extracellular and inducible. The difference in total bacterial diversity between plant rhizospheres is due to that all microorganisms are not attracted in the same way by the root. Indeed, the roots exudates vary from plant to another which leads to a variation in type and quantity of rhizospheric microorganisms [24]. The previous study reported that isolated *Bacillus sp.* B3 was found to be effective starch hydrolyser [25].

### Screening of protease producing bacteria

Out of 24 bacterial isolates 13 strains were showed the protease activity on the skim milk agar plates. Protease activity was observed from the zone of hydrolysis on agar surface and results presented in Fig.3. The similar results were reported that 178 bacterial strains were isolated from the soil samples collected from different regions of India out of which, 20 bacterial isolates were selected for alkaline protease production [26]. Followed by similar results were reported that forty-eight *Bacillus* species were isolated from soil samples and among these ten isolates gave clear zones when screened on casein agar [27].

### Screening of Phosphatase producing bacteria

Out of 24 bacterial isolates 4 strains were showed the phosphatase activity on the PVK agar medium. The Phosphatase activity was observed from the halo zone of PVK agar medium and results presented in Fig.4. Phosphorus is present in soil in the form of organic and inorganic form, so plant does not utilize the complex material of phosphorous. Due to the presence of phosphate solubilizing bacteria in soil, the complex material is converted into simple form to plants. The similar results were reported that a phosphate solubilizing bacterium, PSB-37, was isolated from mangrove soil of the Mahanadi river delta region [28].

## CONCLUSION

Soil vegetation, which is the variety of species living under our feet, has many essential features and functionality. Soil organisms exhibit a fascinating variety of body types, living habits, and ecological interactions. Soil biodiversity is a crucial parameter for maintaining soil fertility and productivity-thus safeguarding food production. The need for increased agricultural production, or the climate change adaptation criteria, present challenges for humanity. Soil is a resource that is limited and increasingly diminishing, and is likely to come under rising pressure from human activities like agriculture. The dynamic ecological relationships between soil species and agriculture are still not well understood. Nevertheless, there are already many tools and management techniques available for sustainable soil management, although the use of these tools and techniques could be enhanced. As is so often the case with problems of this nature, solutions can be elusive, and consensus between stakeholders is hard to come by. All should accept, however, that soil is of utmost importance, and therefore strategies for its protection should be found. In this study, there are number indigenous bacterial strains were isolated from the groundnut cultivated soil. The isolated strains comes under the genera of *Bacillus* spp, *Micrococcus* spp, *Acenitobacter* spp, *Pseudomonas* spp, *Lacobacillus* spp and *Azotobacter* spp and have ability to produce the enzyme activity amylase, protease, catalase, oxidase and phosphatase. These enzyme activities significantly influence the growth of plants. Soil requires farmers, the public and policy makers to protect and carefully maintain it - this is necessary if we are to sustain the mechanism that supports our lives and help us to develop our future.





Sathya et al.

## REFERENCES

- Alexandratos, N., Bruinsma, J., 2012. World agriculture towards 2030/2050: the 2012 revision (No. 12-03, p. 4). ESA Working paper. FAO, Rome.
- FAO, 2004 Food and Agricultural Organization of the United States. Production yearbook, 51(142):104-5.
- Shrivastava, P., Kumar, R., 2015. Soil salinity: a serious environmental issue and plant growth promoting bacteria as one of the tools for its alleviation. Saudi J. Biol. Sci. 22, 123-131.
- Clemens, S., Ma, J.F., 2016. Toxic heavy metal and metalloids accumulation in crop plants and foods. Annu. Rev. Plant Biol. 67, 489-512.
- Kamran, M.A., Eqani, S.A.M.A.S., Bibi, S., Xu, R.K., Monis, M.F.H., Katsoyiannis, A., Bokhari, H., Chaudhary, H.J., 2016. Bioaccumulation of nickel by *E. sativa* and role of plant growth promoting rhizobacteria (PGPRs) under nickel stress. Ecotoxicol. Environ. Saf. 126, 256-263.
- Ma, Y., Rajkumar, M., Zhang, C., Freitas, H., 2016. Inoculation of *Brassica oxyrrhina* with plant growth promoting bacteria for the improvement of heavy metal phytoremediation under drought conditions. J. Hazard. Mater. 320, 36-44.
- FAOSTAT, Food and Agricultural Organization of the United Nations, Statistics Division, 2013. Export Quantities for 'Groundnuts shelled' in 2013; Crops and Livestock Products; Pick Lists for Regions/World List/Export Quantity (Retrieved 15th July April 2017).
- Dinakar, N., Nagajyothi, P.C., Suresh, S., Udaykiran, Y., Damodharam, T., 2008. Phytotoxicity of cadmium on protein, proline and antioxidant enzyme activities in growing *Arachis hypogaea* L. seedlings. J. Environ. Sci. 20, 199-206.
- Shi, G., Cai, Q., 2009. Leaf plasticity in peanut (*Arachis hypogaea* L.) in response to heavy metal stress. Environ. Exp. Bot. 67, 112-117.
- Wang, G., Wu, L., Zhang, H., Wu, W., Zhang, M., Li, X., Wu, H., 2016. Regulation of the phenylpropanoid pathway: a mechanism of selenium tolerance in peanut (*Arachis hypogaea* L.) seedlings. J. Agric. Food Chem. 64, 3626-3635.
- Moreno, J.L., Garcia, C., Hernandez, T., 2003. Toxic effect of cadmium and nickel on soil enzymes and the influence of adding sewage sludge. Euro. J. Soil. Sci. 54, 377-386.
- Pascual, J.A., Garcia, C., Hernández, T., M. Ayuso, 2000. Changes in the microbial activity of an arid soil amended with urban organic wastes. Biol. Fert. Soil. 24(4): 429-434.
- Nannipieri, P., Kandeler, E., Ruggiero, P., 2002. Enzyme activities and microbiological and biochemical processes in soil. In: Burns, R.G., Dick, R.P. (Eds.), Enzymes in the Environment: Activity, Ecology and Applications. Marcel Dekker, New York, pp. 1-33.
- Rodriguez, H., Fraga, R., 1999. Phosphate solubilizing bacteria and their role in plant growth promotion. Biotechnol. Adv. 17 319-339.
- Bal, H.B., Nayak, L., Das, S., Adhya, T.K., 2013. Isolation of ACC deaminase producing PGPR from rice rhizosphere and evaluating their plant growth promoting activity under salt stress. Plant Soil. 366, 93-105.
- Suarez, C., Cardinale, M., Ratering, S., Steffens, D., Jung, S., Montoya, A.M.Z., Geissler-Plaum, R., Schnell, S., 2015. Plant growth-promoting effects of *Hartmanniella diazotrophicus* on summer barley (*Hordeum vulgare* L.) under salt stress. Appl. Soil Ecol. 95, 23-30.
- Banik, A., Mukhopadhyaya, S.K., Sahana, A., Das, D., Dangar, T.K., 2016b. Fluorescence resonance energy transfer (FRET)-based technique for tracking of endophytic bacteria in rice roots. Biol. Fert. Soils. 52, 277-282.
- Sobariu, D.L., Fertu, D.I.T., Diaconu, M., Pavel, L.V., Hlihor, R.M., Drăgoi, E.N., Curteanu, S., Lenz, M., Corvini, P.F.X., Gavrilescu, M., 2016. Rhizobacteria and plant symbiosis in heavy metal uptake and its implications for soil bioremediation. New Biotechnol.
- Banik, A., Mukhopadhyaya, S.K., Dangar, T.K., 2016a. Characterization of N<sub>2</sub>-fixing plant growth promoting endophytic and epiphytic bacterial community of Indian cultivated and wild rice (*Oryza* spp.) genotypes. Planta 243, 799-812.
- Bertrand, T.F., Frederic, T., Robert, N., 2004. Production and Partial Characterization of a thermostable amylase from Ascomycetes yeast strain isolated from starchy soil. McGrawHill Inc, New York. pp. 53-55.





## Sathya et al.

21. Bala, J.D, Abioye, O.P, Auta, H.S, Damisa, D, Adabara, N.U, Tuggen, T.O., 2013. Screening of soil microorganisms for amylase production. Bio. Tech. Ind. J. 7(1): 22-27.
22. Tiwari, M, Ghosh, A, Satyapal, G.K, Kumar, A., 2018. Phosphate Solubilization Activity of Bacterial Strains Isolated from Gangetic Plains of North Bihar. J. Biotech. Biochem. 4, 1-8.
23. Whipps, M.J., 2001. Microbial interactions and biocontrol in the rhizosphere. J. Expe. Botany. 52, 487-511.
24. Fuchs, J.G and Herisse, J.M., 1999. Fertilite des sol. Biopht sa. 1-41.
25. Singh, P, Kumari, P., 2016. Isolation and characterization of amylase producing Bacillus spp. from selected soil sample. Int. J. Res. Biosciences. 5, 24-29.
26. Saxena, A.K, Yadav, A.N, Kaushik, R, Tyagi, S, Kumar, M, Prasanna, R, Shukla, L., 2014. Use of microbes from extreme environments for the benefits of agriculture. In: Afro-Asian Congress on microbes for human and environmental health. Amity University, Noida New Delhi.
27. Suberu, Y, Akande, I, Samuel, T, Lawal, A, Olaniran, A., 2019. Optimization of protease production in indigenous Bacillus species isolated from soil samples in Lagos, Nigeria using response surface methodology. Biocat. Agri. Biotechnol. 18, 101011.
28. Behera, B.C, Yadav, H, Singh, S.K, Mishra, R.R, Sethi, B.K, Dutta, S.K, Thatoi, H.N., 2017. Phosphate solubilization and acid phosphatase activity of Serratia sp. isolated from mangrove soil of Mahanadi river delta, Odisha, India. J. Genetic Engi. Biotechnol. 15, 169-178.

Table 1. Identification of bacteria from agricultural soil samples

S. No	Strain No	Gram's Stain.	Spore Stain.	Motility	Catalase	Oxidase	OF	Genera
1	KA1	G <sup>+Ve</sup> Rod	+	+	+	+	+	Bacillus sp.
2	KA2	G <sup>-Ve</sup> rod	-	-	+	-	-	Acinetobacter sp.
3	KA3	G <sup>+Ve</sup> Cocci	-	-	+	+	-	Micrococcus sp.
4	KA4	G <sup>+Ve</sup> Rod	+	+	+	+	+	Bacillus sp.
5	KA5	G <sup>+Ve</sup> Cocci	-	-	+	+	-	Micrococcus sp.
6	KA6	G <sup>+Ve</sup> Rod	+	+	+	+	+	Bacillus sp.
7	KA7	G <sup>-Ve</sup> rod	-	-	+	-	-	Acinetobacter sp.
8	KA8	G <sup>+Ve</sup> Rod	+	+	+	+	+	Bacillus sp.
9	KA9	G <sup>-Ve</sup> rod	-	-	+	+	+	Pseudomonas sp
10	KA10	G <sup>+Ve</sup> Rod	+	+	+	+	+	Bacillus sp.
11	KA11	G <sup>+Ve</sup> Cocci	-	-	+	+	-	Micrococcus sp.
12	KA12	G <sup>+Ve</sup> rod	+	+	+	+	-	Bacillus sp.
13	KA13	G <sup>-Ve</sup> rod	-	-	+	-	-	Acinetobacter sp.
14	KA14	G <sup>+Ve</sup> Rod	+	+	+	+	+	Bacillus sp.
15	KO1	G <sup>+Ve</sup> Rod	+	+	+	+	+	Bacillus sp.
16	KO2	G <sup>+Ve</sup> Cocci	-	-	+	+	-	Micrococcus sp.
17	KO3	G <sup>+Ve</sup> Rod	+	+	+	+	+	Bacillus sp.
18	KO4	G <sup>+Ve</sup> Cocci	-	-	+	+	-	Micrococcus sp.
19	KO5	G <sup>+Ve</sup> Rod	+	+	+	+	+	Bacillus sp.
20	KO6	G <sup>+Ve</sup> Rod	-	+	+	+	+	Azotobacter sp.
21	KO7	G <sup>+Ve</sup> Rod	+	+	+	+	+	Bacillus sp.
22	KO8	G <sup>+Ve</sup> rod	+	-	-	-	-	Lactobacillus sp.
23	KO9	G <sup>+Ve</sup> Rod	-	+	+	+	+	Azotobacter sp.
24	KO10	G <sup>+Ve</sup> rod	+	-	-	+	-	Bacillus sp.





Sathya et al.

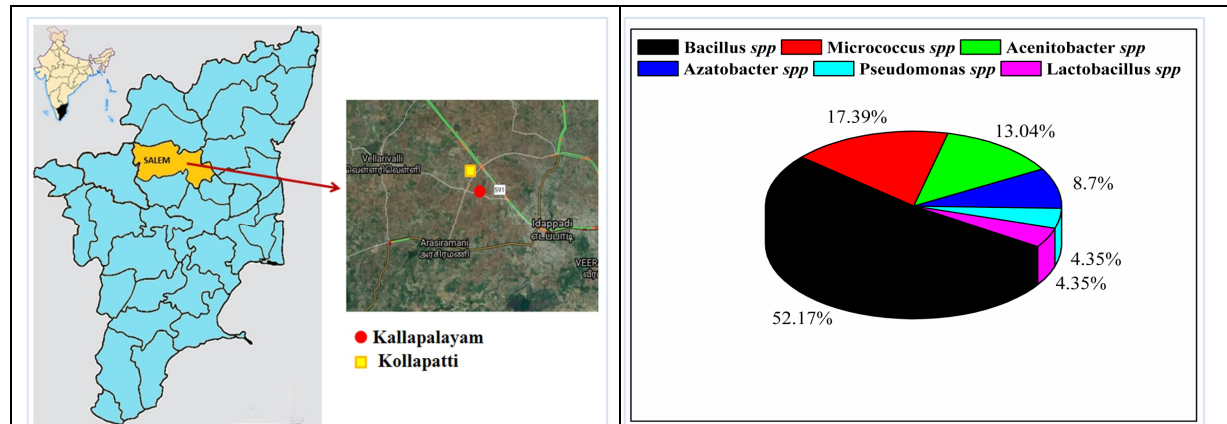

Figure 1. Study area and sampling sites in Idappadi block of Salem district

Figure.2. Percentage of bacterial genera in collected soil sample

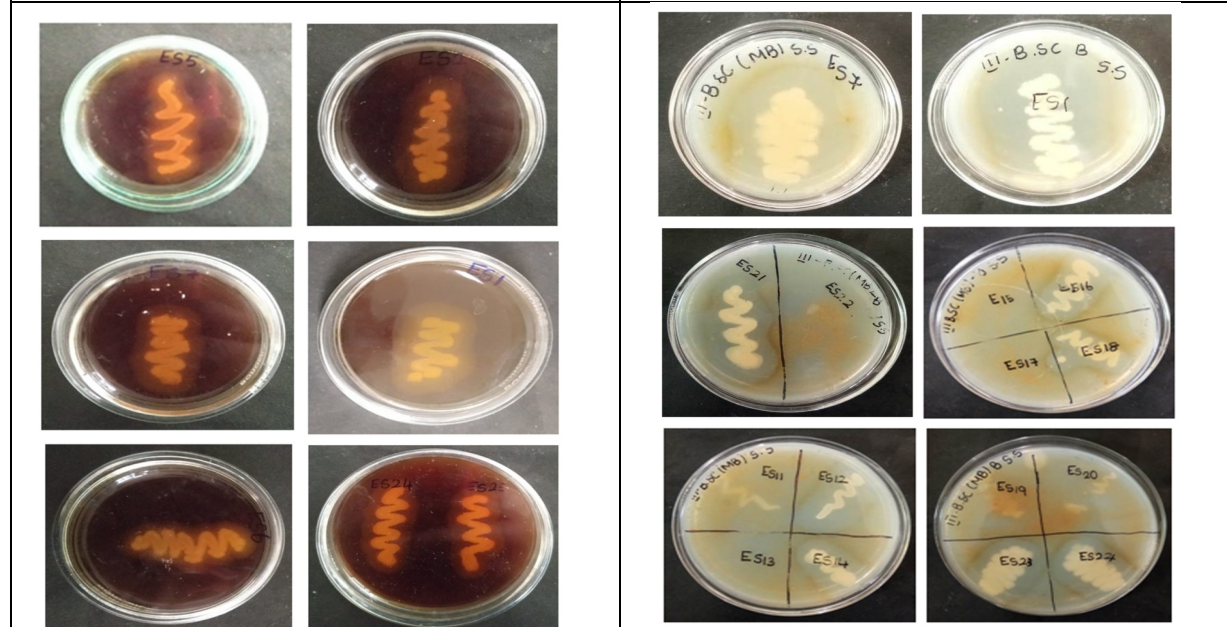

Figure.3. Screening of amylase producing bacteria

Figure.4. Screening of protease producing bacteria

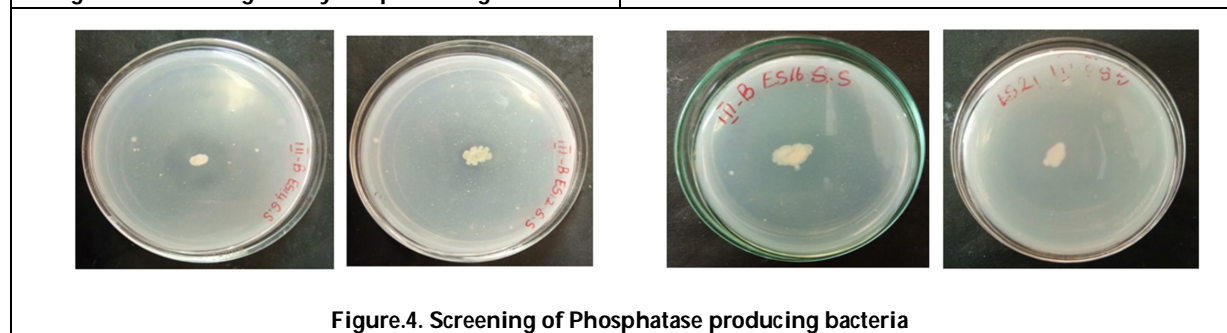

Figure.4. Screening of Phosphatase producing bacteria





## Studies on Limnological Parameters of Sankara Pond, Sundargarh, Odisha

Saibalini Patel and Pradip Kumar Prusty\*

Department of Zoology, School of Applied Sciences, Centurion University of Technology and Management, Odisha, India

Received: 19 Jan 2020

Revised: 21 Feb 2020

Accepted: 25 Mar 2020

### \*Address for Correspondence

#### Pradip Kumar Prusty

Department of Zoology,  
School of Applied Sciences,  
Centurion University of Technology and Management,  
Odisha, India  
Email: pradipkumar.prusty@cutm.ac.in



This is an Open Access Journal / article distributed under the terms of the **Creative Commons Attribution License** (CC BY-NC-ND 3.0) which permits unrestricted use, distribution, and reproduction in any medium, provided the original work is properly cited. All rights reserved.

### ABSTRACT

A pond ecosystem is characterised by relatively quiet water and abundant vegetation. It is a small area of still, fresh water. The present investigation was carried out in Sankara pond which is present in the heart of Sundargarh town, Odisha. The pond is home to many water birds, local as well as migratory. Due to anthropogenic activities there is rapid degradation of water bodies. Hence bioremediation is required in order to restore the affected water bodies. The study was carried out in winter season from 24<sup>th</sup> December, 2019 to 2<sup>nd</sup> January, 2020. Different physico-chemical parameters and biological parameters of water were analysed during this time interval. The value of most of the physico-chemical parameters of water are in desirable limit except the BOD (6mg/l) value which exceeded the normal limit which indicates the enrichment of water due to the uncontrolled dumping of garbage, debris and sewage. The pH of the water was found to be between 6.87 to 9.05, the conductivity was between 344 to 470 $\mu$ S, the salinity was between 0.22 to 0.24ppt, the turbidity was between 1.55 to 2.33 NTU, the TDS was between 200ppm to 218ppm and the total hardness during the study period was 100mg/l, the calcium and magnesium value was 20.84 mg/l and 11.66 mg/l respectively. The water quality of the Sankara pond was moderate for aquatic organisms, for aquaculture and agricultural uses, though it is moderate for aquatic organisms it need to be restored because of the increase in BOD level.

**Key Words:** Limnology, sankara pond, physico-chemical parameters, Zooplankton, water birds.



**Saibalini Patel and Pradip Kumar Prusty**

## INTRODUCTION

Water is a vital component necessary for life without it, there is no life. The study of water bodies is equivalent to the study of life (Dutta and Patra, 2013). The credit of scientific studies on freshwater goes to P.A.Forel (1901). Who used the term 'limnology' for the first time and is regarded as the father of modern limnology. Limnological studies covers the study of freshwater bodies such as lakes, ponds, river, wetland and estuaries but now a days it also includes inland salt water system (Welch, 1952). Studies on freshwater bodies, that may be natural or manmade has gained much importance in recent year because of their multiple uses (Balakrishna et. al., 2013). In recent time limnology plays an important role in water use and distribution as well as in aquatic habitat protection. A basic feature of earth is abundance of water, which extends over 71% of its surface to an average depth of 3800m (Wetzel 2001). About 97% of the total water available is salt water and the remaining 3% is freshwater. Water resources are declining day by day due to increase in population which result in increasing urbanization. Deterioration of the water quality is now a global problem (Mahananda et al., 2010). The purity of water varies from place to place in nature (Patil 2013). The quality of water of any aquatic ecosystem arises by the intercommunication of chemical, physical and biological component. The physico-chemical parameters have important significance in determining the trophic status of aquatic habitats (Sharma et al., 2009). Pond as an ecosystem is characterised by relatively quiet water and abundant vegetation. The important component of pond ecosystem are:

### Abiotic components

The abiotic component of a pond ecosystem includes all the non-living molecules such as water, oxygen, carbon dioxide, calcium, magnesium, potassium etc.

### Biotic components

The biotic components of pond ecosystem includes the living organisms they may be producer (phytoplankton and macrophytes), consumer (zooplankton, fishes, and waterfowl) and decomposer (microorganisms). Sundargarh is a district in the north-western part of Odisha state in eastern India. The district has a sub-tropical climate and intensity mildly extreme. The Sundargarh district lies between 21.47'7" to 22.32'2" N latitude and between 83.32'19" to 84.34'18" E longitude. All the 17 blocks of the district has various water bodies, viz. ponds, reservoirs, streams, wells, paddy fields and river. Sankara pond is situated in the heart of the city. It is an important wetland which is home to resident and winter visitor avifauna. The bird density were more in winter season rather than other seasons as there was optimum water storage, availability of abundant food, increase vegetation and the arrival of migratory birds. The waterfowl population and distribution in the Sankara pond is regulated by invertebrates and the wetland birds largely feed on a wide range of the invertebrate community and small fishes.

## MATERIALS AND METHODS

### Study area

Selected pond is situated in the heart of the city, Sundargarh, Odisha. Sampling sites for the water body are selected to collect water sample. The grab samples were collected from five different sites, enough to assess their physical and chemical and biological parameters at alternate days in the month of December from 24.12.2019 to 02.01.2020 between 9: 00-10:00 am. From each site water samples were collected in thoroughly cleaned 1 litre inert plastic containers. Before the collection of sample the containers were rinsed with distilled water to avoid contamination for the analysis of physico-chemical properties and zooplankton. Water samples were collected in sampling bottle avoiding floating materials. The closed bottle was dipped in the lake at the depth of 0.5M below the surface, and then a bottle was opened inside and was closed again to bring it out at the surface (Verma et al., 2011). The cap of the sample containers were closed properly to prevent outside contamination. The container was labelled describing the date, time and sampling site.



**Saibalini Patel and Pradip Kumar Prusty**

Different physico-chemical parameters such as colour of water, odour, taste, air temperature, water temperature, pH, dissolved oxygen, conductivity, salinity, total dissolved solid were measured by Systronics water analyser 371, whereas the analyses of remaining parameters like BOD, COD, total hardness, calcium, magnesium and free carbon dioxide were determined by in the laboratory by method suggested by Abbasi (1998), APHA-AWWA AND WPCF (2005). The species assemblage of Zooplankton is useful in assessing water quality. Zooplankton was collected using plankton net and the collected sample were preserved in 5% formalin. The preserved sample were brought to laboratory for analysis. Quantitative studies were made by using Sedgwick rafter cell. Zooplankton were identified by using the methods given by Battish (1992) and Dhanapat, (2000). The macrophytes and fishes found in the pond were also observed and recorded. The aquatic birds and other terrestrial birds present around the study area were also observed with the help of binoculars, recorded and identified using photographic field guide to "Birds of Sundargarh Forest Division" (Naik et al., 2017).

**RESULTS AND DISCUSSION**

During the study period (24.12. 2019 to 02.01.2020) the weather condition was bright. The water sample was clear greenish in four sampling sites and light muddy in fifth sampling site.

**Air and water temperature**

The minimum and maximum ambient temperature of Sankara pond ranges from 19°C to 27°C and the water temperature varied from 13°C to 21°C during the study period. The temperature was low in 26.12.2019 and the high temperature recorded in the study period was in 24.12.2019.

**pH**

The pH value recorded ranges from 6.87 to 9.05. The highest value of pH was recorded from the site-1 and the lowest was recorded from site -5. The low pH value indicates that the slightly acidic nature of the pond water and high pH basic nature of the water. The pH value affects most of the biological processes and biochemical reactions in water body (Arya et al., 2011)

**Electrical conductivity**

Conductivity values depends on the nature of the various ions present in the water sample, their relative concentrations and the ionic strength. Conductivity recorded in Sankara pond range from 344 $\mu$ S to 470  $\mu$ S. The high value of conductivity was recorded in site 1 and the low value was recorded in site 5.

**Salinity**

In the Sankara pond the amount of salinity recorded ranges from 0.22 ppt to 0.24 ppt. The maximum value of salinity was recorded in site 5 and the minimum value was recorded in site 1.

**Total dissolved solid**

The solids present in water in the dissolved state are known as total dissolved solids. In the Sankara pond the amount of total dissolved solid recorded ranges from 200 ppm to 218 ppm. TDS values in ponds, Lakes and streams are typically found to be in the range of 50 to 250 ppm.

**Turbidity**

Suspension of particles in water hindering with passage of light is called turbidity. Turbidity in Sankara pond ranges from 1.55 NTU to 2.33 NTU. The high value was recorded in site 5 as the water was light muddy.

**Total hardness**

The hardness causing ions in water are mainly calcium and magnesium and are the measure of the capacity of water to react with soap. The amount of hardness in the water of Sankara pond recorded was 100mg/l.





**Saibalini Patel and Pradip Kumar Prusty****Calcium and magnesium**

Both the calcium and magnesium ions present in water cause the hardness of water. The observed value of calcium in Sankara pond was 20.84mg/l and the observed value of magnesium was 11.66mg/l.

**BOD**

Biological oxygen demand (BOD) is the amount of oxygen required by microorganism for stabilizing biologically decomposable organic matter in water under aerobic conditions. The observed value of BOD in Sankara pond was 6mg/l. As BOD exceeds 3mg/l, hence the water of the Sankara pond need water treatments.

**COD**

Chemical oxygen demand (COD) is the measure of oxygen equivalent to the organic content of the sample that is susceptible to oxidation by a strong chemical oxidant. The observed value of COD in Sankara pond was 20 mg/l.

**Zooplankton**

Zooplankton considered being the ecological indicator of water bodies. Physico-chemical parameters, light intensity, food availability, and predation effect the population dynamics of zooplankton. Low pH or high salinity can reduced their diversity and density. In the present investigation the diversity of zooplankton were represented by *Rotifera*, *Protozoa*, *Cladocera*, *Copepoda* and *Ostracoda*.

**Macrophytes**

Macrophytes in an aquatic ecosystem are particularly important as they are the producer and are responsible for photosynthesis and they provide habitat for many smaller aquatic organism as well as feeding and breeding ground for many fishes by supporting many invertebrate species which take shelter among the macrophytes and also for the water birds. The dominate species of macrophytes present in Sankara pond are *Nymphaeaurubra*, *Elodea sp.*, *Hydrilla sp.* and *Marsilea sp.*

**Fishes**

A comprehensive knowledge of the limnological features of any aquatic environment in which fish live is vital for assessing its productivity and suitability for rearing fish. Biological production in any aquatic body gives direct correlation with its physico-chemical status which can be used as trophic status and fisheries resources potential (Jhingran et al., 1969). The dominate fish species present in Sankara pond were *Channa striatus*, *Channa punctatus*, *Clarius batrachus*, *Anabas testudineus* and *Puntius amphibious*.

**Avifauna**

Wetland provide an important habitat for feeding and breeding for many species of aquatic birds. Many species of birds are highly adapted to live in water bodies. During the course of the present study, the bird species encountered were also recorded. A total of 22 species belonging to 14 family were recorded.

**CONCLUSION**

From the present study it is concluded that limnological study is very useful to get a fairly accurate idea of quality of the water by determining a few physico-chemical parameters. From the study it is reveal that all the physico-chemical parameters of the pond are within the desirable limit except the BOD value. The BOD exceeds the normal value because of the flow of fertilizer from the agricultural land surrounding the pond hence required water treatment. As all the physico-chemical parameters are under desirable limit so, the water of Sankara pond is moderate for aquaculture, bathing and agricultural uses.





**Saibalini Patel and Pradip Kumar Prusty**

## REFERENCES

1. Abbasi, S.A. 1997. Wetlands of India-Ecology and Threats; Discovery Publishing House, New Delhi, 127-148.
2. Abbasi, S.A. 1998. Water quality sampling and analysis; Discovery publishing house, New Delhi.
3. Abraham, S. 1973. The Kanjrankulam breeding bird sanctuary in the Ramanand District of Tamil Nadu. J. Bom. Nat. Hist. Soc., 70(33): 549-552.
4. Akin, B.S., Atici, T. and Katircioglu, H. 2008. Physicochemical, toxicological and ecological analysis of Gokcekaya dam Lake; African Journal of Biotechnology, 7(4), 444-449.
5. Ahmad, U., S. Parveen, A.A. Khan, H.A. Kabir, H. R.A. Mola and A.H. Ganai 2011. Zooplankton population in relation to physicochemical factors of sewage fed pond of Aligarh (UP), India. Biology and Medicine, 3(2) special Issue: 336-341.
6. Ali, S. 1933. The Hyderabad state ornithological survey. J. Bom. Nat. Hist. Soc., 40: 497-499.
7. Ali, S. 1996. The book of India birds. Oxford Univ. Press, London.
8. Allan, J.D., Flecker, A.S. 1993. Biodiversity conservation in running waters; Bioscience, 43(1): 32-43.
9. Anonymous, 2006. Comprehensive wildlife management plan for Nandankanan sanctuary, Forest and Environment Department, Government of Orissa.
10. Anonymous, 2010. Conservation and management of Lakes: An Indian Perspective; Ministry of environment and forests, Government of India.
11. APHA, AWWA, WEF 1999. Standard Methods for the examination of water and wastewater; American Public Health Association, American Water Works Association, Water Environment Federation.
12. Bais, V.S. and N.C. Agrawal 1995. Comparative study of the zooplanktonic spectrum in the Sagar Lake and Military Engineering Lake. J. Environ. Bio., 16(1): 27-32.
13. Balachandran, S.A., Rahamani, A. and Sathiyaselvem, P. 2005. Habitat evaluation of Chilika Lake with special reference to birds as bio-indicators, Final report 2001-2005.
14. Balakishna.D., Reddy, T.R., Reddy, K.V. and Samatha, D. 2013. Physico-chemical parameters and plankton diversity of Ghanpur Lake, Warangal, A.P., India. International Journal of Zoology Research: 44-48.
15. Battish, S.K. 1992. Freshwater zooplankton of India. Oxford and IBH Publishing Co. Pvt. Ltd. New Delhi.
16. BIS 1991. Indian Standard Drinking Water- Specification (BIS 10500: 1991).
17. Choudhary, S.K., M. Nayak, R.B. Singh and P. Bannenee 1991. Diurnal variation in some physicochemical and biological parameters of two ponds at Bhagalpur (Bihar). Natl. Acad. Sci. Lett., 14(10): 403-407.
18. Daniels, R.R.J. 2002. Fresh water fishes of peninsular India; University press, Hyderabad: 04-05.
19. Dhanapathi, M.V.S. 2000. Taxonomic notes on the rotifers from India (from 1889-2000). Indian Association of Aquatic Biologists, Publ. No.10.
20. Dhamija, S.K. and Jain, Y. 1994. Variations in the physicochemical characteristics of a lentic water body of Jabalpur (M.P.); J EnvPolln, 1(3&4) 125-128.
21. Gawas, A.D., Lokhande, P.B. and Mejjawas, H.A. 2006. Study of physico-chemical parameters of surface water in the Mahad Industrial Area. Poll. Res. 25(1): 109-114.
22. Hardikar, R.S. and Acharya, C.A. 2013. Comparative Analysis of physico-chemical properties of two fresh water bodies of Ahmedabad city, Gujarat; Life science leaflets, 4(2013): 81-84.
23. Indresha, G.N., and Patra, A.K. 2014. Seasonal Variation in the Physico-chemical parameters of Kanjia Lake, Nandankanan; e-planet: 55-64.
24. Jain, R. 2008. Physico-chemical seasonal analysis of Singwasa reservoir, Gunu, M.P. (India); Journal of Environmental Research and Development, 3(1):191-197.
25. Jhingran, V.G., A.L. Natrajan, S.M. Banarjee, and A. David 1969. Methodology on reservoir fisheries investigation in India. Bull. Cent. Ini. Fish. Res. Ins. Barrackpore, 12:1-109.
26. Jyoti, M.k., Sharma, K.k, and Sharma, Jyoti 2009. Seasonal variation in physico-chemical aspects of a fish pond, Jammu, India: Current World Environment, 4(1): 207-210.
27. Kamal, S, Indresha, G.N., Mishra, A.K. and Parida, S.P. 2009. Vertebrate faunal diversity at Kanjia Lake, Nandankanan; e-planet, 7(2): 29-33.



**Saibalini Patel and Pradip Kumar Prusty**

28. Mahananda, M.R., B.P.Mohanty and N.R. Behera 2010. Physico-chemical analysis of surface and ground water of Bargarh District, Odisha India. *Int. J. Res. Rev. Appl. Sci.*, 2(3): 23-29.
29. Mathur, P., Patan, s., sharma, K., Nair, N. and Shobhawat, A. 2010. Assessment Physico-chemical properties of Anasagar Lake of Ajmer (India); *Journal of Environmental Research and Development*, 4(3): 780-787.
30. Nayak, B.K., Acharya, B.c., Panda, U.C., Nayak, B.B. and Acharya, S.K. 2004. Variation of water quality in Chilika Lake, Odisha; *Indian J. Mar. Sci.*, 33(2): 164-169.
31. Patil, A.A. 2013. Status of water quality of Bhambarde and Lengre reservoir of Sangli district, Maharashtra, India. *Flora and Fauna*, 19(1): 35-40.
32. Patra, A.P., Patra, J.K., Mahapatra, N.K., Das, S. and Swain, .C. 2010. Seasonal variation in Physico-chemical parameters of Chilika Lake after opening of New MouthnearGabakunda, Odisha, India; *World Journal of Fish and Marine Sciences*, 2(2): 109-117.
33. Postel, s. and Carpenter, s. 1997. *Freshwater Ecosystem Services*; In *Nature's Services*, G.C. Daily (ed.). Island press, Washington D.C.
34. Rahel, F.J. 2002. Homogenization of Freshwater faunas; *Annu. Rev. Ecol. Syst.*, 33: 291-315.
35. Sachidanandamurthy, K.L. and Yajurvedi, H.N. 2006. A study on physicochemical parameters of an aquaculture body in Mysore city, Karnataks, India; *Journal of Environmental Biology*, 27(4): 615-618.
36. Sahib, S.S. (2004) Physicochemical parameters and zooplankton of the Shendurniriver, Kerala. *Journa; of Ecobiology*, 16(2): 32-37.
37. Sharma, K., K. Shvetambri, P. Verma and S.P. Sharma 2009. Physico-chemical assessment of three freshwater ponds of Jammu (J&K), *Curr. World Environ.*, 4(2): 367-373.
38. Siddhartha, R., Tanti, K.D., Mishra, A. and Pandey, B.N. 2013. Seasonal rhythms in the physic\_chemical characteristics of the swamps of Purnia, (Bihar); *Int. J. of Life Sciences*, 1(1): 63-66.
39. Siddiqi, S.z. and Rao, K.V.R. 1995. *Limnology; wetland Ecosystem Series 1: Fauna of Chilika Lake*, ZSI, Calcutta: 11-136.
40. Swarnalatha, N. 1994. Seasonal rhythms of various physico-chemical characteristics of a Lake: *J Mendel*, 11(1&2): 65-66.
41. Telkhade, P.M., Zade, S.B. and Dahegaonkar, N.R. (2012) *Water Quality status of Tadoba Lake*, Chandrapur, Maharashtra, India; *Ecorevolution*, Colombo, Srilanka: 11-14.
42. Verma, P., Chandawat, D., Gupta, U. and Solanki, H. 2012. Water quality of an organically polluted Lake by investigating different physical and chemical parameters: *Int. J Res. Chem. Environ.*, 2(1): 105-11.
43. Welch, P.S. 1948. *Limnological Methods*, McGraw-Hill companies, reprinted copyright © 2003, Narendra Publishing House, Delhi.
44. Wetzel, R.G. 2001. *Limnology: Lake and River Ecosystem*; 3<sup>rd</sup> Edition, Academic Press, London.

**Table-1. water colour during winter season (24.12.2019 to 02.01.2020)**

DATE	SITE-1	SITE-2	SITE-3	SITE-4	SITE-5
24.12.2019 TO 02.01.2020	CLEAR (GREENISH)	CLEAR (GEENISH)	CLEAR (GREENISH)	CLEAR (GEENISH)	LIGHT MUDDY (LIGHT MUDDY)

**Table-2. Variation in air temperature during winter season (24.12.2019 to 02.01.2020)**

DATE	SITE-1	SITE-2	SITE-3	SITE-4	SITE-5	MIN	MAX	MEAN	±S.D
24.12.2019	27.1	26.8	26.4	27.4	26.9	26.4	27.4	26.92	0.331
26.12.2019	19.3	19	18.6	19.2	19.4	18.6	19.4	19.1	0.282
28.12.2019	24.2	24.3	23.8	23.4	24.3	23.4	24.3	24	0.352
30.12.2019	23.1	22.9	22.5	23.2	23.4	22.5	23.1	23.02	0.305
02.01.2020	26.3	26.7	25.6	26.1	26.5	25.6	26.7	26.24	0.377





**Saibalini Patel and Pradip Kumar Prusty**

**Table-3. Variation in water temperature (°C) during winter season (24.12.2019 to 02.01.2020).**

DATE	SITE-1	SITE-2	SITE-3	SITE-4	SITE-5	MIN	MAX	MEAN	±S.D
24.12.2019	21	20.3	19.8	20.4	20.1	19.8	21	20.32	0.3969
26.12.2019	13.1	12.9	11.9	13	13.2	11.9	13.2	12.82	0.4707
28.12.2019	16.9	17	17.2	17.1	17.1	16.9	17.2	17.2	0.1732
30.12.2019	17.2	17	16.8	16.8	17.2	16.8	17.2	17	0.1788
02.01.2020	19	18.1	18.3	18.1	18.2	18.1	19	18.34	0.338

**Table- 4. Variation in pH during winter season (24.12.2019 to 02.01.2020).**

DATE	SITE-1	SITE-2	SITE-3	SITE-4	SITE-5	MIN	MAX	MEAN	±S.D
24.12.2019	9.05	7.9	7.25	7.52	6.97	6.97	9.05	7.684	0.56887
26.12.2019	8	7.4	7.1	6.9	6.88	6.9	8	7.256	0.41634
28.12.2019	9.05	7.9	7.58	7.37	6.95	6.95	9.05	7.77	0.71046
30.12.2019	8.37	7.42	7.24	7.36	6.87	6.87	8.37	7.452	0.4971
02.01.2020	9.03	7.45	7.65	7.48	6.85	6.85	9.03	7.692	0.7217

**Table-5. Variation in conductivity (µS/cm) during winter season (24.12.2019 to 02.01.2020).**

DATE	SITE -1	SITE-2	SITE-3	SITE-4	SITE-5	MIN	MAX	MEAN	±S.D
24.12.2019	450	346	365	350	345	345	450	371.2	40.0469
26.12.2019	445	356	370	365	365	356	445	380.2	32.7133
28.12.2019	470	355	359	364	375	355	470	384.6	43.22314
30.12.2019	420	346	344	356	345	344	420	362.2	29.2191
02.01.2020	435	345	350	370	350	345	435	370	33.6154

**Table-6. Variation in salinity (ppt) during winter season (24.12.2019 to 02.01.2020)**

DATE	SITE-1	SITE-2	SITE-3	SITE-4	SITE-5	MIN	MAX	MEAN	±S.D
24.12.2019	0.22	0.22	0.22	0.23	0.23	0.22	0.23	0.224	0.0048989
26.12.2019	0.23	0.22	0.23	0.23	0.24	0.22	0.24	0.23	0.00632455
28.12.2019	0.22	0.23	0.23	0.23	0.24	0.22	0.24	0.23	0.006324
30.12.2019	0.22	0.23	0.23	0.23	0.23	0.22	0.23	0.228	0.004
02.01.2020	0.22	0.22	0.23	0.22	0.23	0.22	0.23	0.224	0.00489

**Table-7. Total dissolved solid Variation in TDS (mg/l) during winter season (24.12.2019 to 02.01.2020).**

DATE	SITE-1	SITE-2	SITE-3	SITE-4	SITE-5	MIN	MAX	MEAN	±S.D
24.12.2019	215	205	202	211	212	202	215	209	4.7749
26.12.2019	218	204	204	209	215	204	218	210	5.692
28.12.2019	216	203	200	207	210	200	216	207.2	5.5641
30.12.2019	218	208	206	214	214	206	218	212	4.3817
02.01.2020	217	207	203	210	211	203	217	209.6	4.6303

**Table-8. Variation in turbidity (NTU) during winter season (24.12.2019 to 02.01.2020).**

DATE	S-1	S-2	S-3	S-4	S-5	MIN	MAX	MEAN	±S.D
24.12.2019 To 02.01.2020	1.57	1.55	1.64	1.56	2.33	1.55	2.33	1.73	0.30166





**Saibalini Patel and Pradip Kumar Prusty**

**Table-9. Values of BOD, COD, Total hardness, Calcium and Magnesium of water osSankara pond durind 24.12,2019 to 02.01.2020**

Sampling date	24.12. 2019 to 02.01.2020
<b>Parameters</b>	
BOD (mg/l)	6
COD (mg/l)	20
Total hardness (mg/l)	100
Calcium (mg/l)	20.84
Magnesium (mg/l)	11.66

**Table-10. List of some common zooplankton recorded in Sankara pond**

Zooplankton type	
<b>PROTOZOA</b>	
1.	<i>Amoeba sp.</i>
2.	<i>Arcella gibbosa</i>
3.	<i>Paramecium caudatum</i>
<b>ROTIFERA</b>	
4.	<i>Brachionus calcyflorus</i>
5.	<i>Brachionus foricula</i>
6.	<i>Asplanchna priodonta</i>
7.	<i>Filina longiseta</i>
<b>CLADOCERA</b>	
8.	<i>Daphnia carinata</i>
9.	<i>Moina micrura</i>
<b>OSTRACODA</b>	
10.	<i>Cypris sp.</i>
11.	<i>Centro cypris sp.</i>
<b>COPEPODA</b>	
12.	<i>Diaptomus wierzeskii</i>
13.	<i>Mesoclops sp.</i>

**Table- 11. List of some common fish species recorded in the Sankara pond**

SL No.	Common name	Scientific name	Family	Order
1.	Striped Snakhead	<i>Channa striatus</i>	Channidae	Perciformes
2.	Spotted Snakhead	<i>Channa punctatus</i>	Channidae	Perciformes
3.	Magur	<i>Clarius batrachus</i>	Clariidae	Siluriformes
4.	Climbing perch	<i>Anabas testudineus</i>	Anabantidae	Anabantiformes
5.	Scarlet-banded barb	<i>Puntius amphibious</i>	Cyprinidae	Cypriniformes

**Table-12. List of bird recorded around the Sankara pond**

SI No.	Common name	Scientific name	Family	IUCN	Migratory Status
1.	Little Grebe	<i>Tachybaptus ruficollis</i>	Podicipedidae	LC	R
2.	Little Cormorant	<i>Phalacrocorax niger</i>	Phalacrocoracidae	LC	R
3.	Little egret	<i>Egretta garzetta</i>	Ardeidae	LC	R
4.	Cattle egret	<i>Bubu us ibis</i>	Ardeidae	LC	R
5.	Indian pond heron	<i>Ardeolagryii</i>	Ardeidae	LC	R
6.	Lesser whistling duck	<i>Dendrocygna javanica</i>	Anatidae	LC	R





## Saibalini Patel and Pradip Kumar Prusty

7.	Norther pintail	<i>Anas acuta</i>	Anatidae	LC	WV
8.	White breasted waterhen	<i>Amaurornis phoenicurus</i>	Rollidea	LC	R
9.	Common coot	<i>Fulica atra</i>	Rollidea	LC	R
10.	Bronze winged jacana	<i>Metopidius indicus</i>	Jacaniidae	LC	R
11.	Pheasant tailed jacana	<i>Hydrophasianus chirurgus</i>	Jacaniidae	LC	R
12.	Lesser coucal	<i>Centropus bengalensis</i>	Cuculidae	LC	R
13.	White throated kingfisher	<i>Hayon smyrnensis</i>	Alcedinidae	LC	R
14.	Indian roller	<i>Coracias benghalensis</i>	Coraciidae	LC	R
15.	Paddy field pipit	<i>Anthus rufulus</i>	Motacilladea	LC	R
16.	Purple moorhen	<i>Porphyrio porphyrio</i>	Rallidae	LC	R
17.	Gadwall	<i>Anus strepera</i>	Anatidae	LC	R
18.	Cotton teal	<i>Nettapus coromandelianus</i>	Anatidae	LC	R
19.	Black drongo	<i>Dicrurus macrocercus</i>	Dicruridae	LC	R
20.	Little green bee eater	<i>Merops orientalis</i>	Meropidae	LC	R
21.	Cinnamon bittern	<i>Lxobrychus cinnamomeus</i>	Ardeidae	LC	R

LC-Least concern

Migratory status (R- Resident, WV- Winter Visitors).

Table-13. Variation in physic-chemical parameters of Sankara pond

Sampling date	24.12.2019		26.12.2019		28.12.2019		30.12.2019		02.01.2020	
	Mean	±S.D	Mean	±S.D	Mean	±S.D	Mean	±S.D	Mean	±S.D
Air temp (°C)	26.92	0.331	19.1	0.282	24	0.352	23.02	0.305	26.24	0.377
Water temp (°C)	20.32	0.397	12.82	0.471	17.2	0.173	17	0.179	18.34	0.338
pH	7.684	0.568	7.256	0.416	7.77	0.71	7.452	0.497	7.692	0.721
Conductivity $\mu\text{S}/\text{cm}$	371.2	40.046	380.2	32.713	384.6	43.223	362.2	29.219	370	33.615
Salinity (ppt)	0.224	0.0048	0.23	0.00632	0.23	0.00632	0.228	0.004	0.224	0.0048
TDS( $\text{mgL}^{-1}$ )	209	4.774	210	5.692	207.2	5.564	212	4.381	209.6	4.63

Table-14. Correlation coefficient values among different physic-chemical parameters

1	Air temp	Water temp	pH	EC	Sal.	TDS
Air temp	1					
Water temp	0.9764	1				
pH	0.858925	0.810914	1			
EC	-0.33013	-0.39259	0.101082	1		
Sal.	-0.82497	-0.7811	-0.45363	0.552888	1	
TDS	-0.28341	-0.21583	-0.6496	-0.80911	-0.08364	1





Saibalini Patel and Pradip Kumar Prusty



Fig. 1 . Study area



Fig. 2. Showing variation in physic-chemical parameters during 24.12.2019 to 02.01.2020





## Wireless Sensor Network Based Real-Time Monitoring of Underground Mine Environment

Jitendra Pramanik<sup>1\*</sup>, Abhaya Kumar Samal<sup>2</sup>, Singam Jayanthu<sup>3</sup> and Subhendu Kumar Pani<sup>4</sup>

<sup>1</sup>Assistant Professor, Centurion University of Technology and Management, Odisha, India,

<sup>2</sup>Professor, Department of CSE, Trident Academy of Technology, Bhubaneswar, Odisha, India

<sup>3</sup>Professor, Department of Mining Engineering, National Institute of Technology, Rourkela, Odisha, India

<sup>4</sup>Professor, Department of CSE, Orissa Engineering College, Bhubaneswar, Odisha, India

Received: 18 Jan 2020

Revised: 20 Feb 2020

Accepted: 23 Mar 2020

### \* Address for Correspondence

**Jitendra Pramanik**

Assistant Professor,

Centurion University of Technology and Management,

Odisha, India,

Email: jitendra.pramanik@cutm.ac.in



This is an Open Access Journal / article distributed under the terms of the **Creative Commons Attribution License** (CC BY-NC-ND 3.0) which permits unrestricted use, distribution, and reproduction in any medium, provided the original work is properly cited. All rights reserved.

### ABSTRACT

Adverse working conditions in the underground mine environment poses many health challenges to the miners due to presence of toxic and combustible gases and other hazardous factors such as strata behavior, roof sag, temperature, humidity, air pressure, mine fire, etc. Such factors affect the opportunity of achieving desired mining productivity due to threatened safety aspect of the underground miners. The traditional approach of air quality monitoring involve large and expensive scientific equipment permanently installed and professionally maintained as an arrangement in specialized laboratories at selected locations. These labs monitor and measure air quality on the basis of the samples collected from fields on a shift to shift basis, resulting in collection of at best three samples per day from selected hot-spot locations only. Continuous progression in the field of wireless communication and micro-electro-mechanical systems (MEMS) technology has resulted in emergence and design of efficient Wireless Sensor Network (WSN) with expanded scope and possibilities of integrating into diverse fields of application. Mining operation is one such domain that has wide scope of incorporating WSN to achieve trusted level of real-time mining safety monitoring and design efficient early warning system. Integration of big-data analytics and machine-learning techniques can extract a lot of intelligence from the accumulated data regarding the understanding of cause and fluctuations in the air-pollutions, its predict trend and provide early warning of possible threats. The primary objective of this paper is to present the design outline of a real-time early warning and safety monitoring (RT-EWSM) system for improving workplace safety conditions in underground mining environment. Proposed model of the RT-EWSM is built on the basis of concepts of cost-effective, low-power wireless solutions.

**Keywords:** Wireless Sensor Network (WSN), Mining Safety, Early Warning System





**Jitendra Pramanik et al.**

## INTRODUCTION

Underground coal mines tunnels pose an extremely harsh environment and confined working conditions. Though in recent years exposure of mine safety and health awareness has definitely minimized mines mishaps; yet, every year thousands of miners are losing their lives due to severe causalities. Therefore, for the safe working of the miners and underground tunnel and sewage line workers, it is highly essential to continuously and accurately monitor the mine environment on real-time basis. Continuous environmental monitoring is highly essential to provide and maintain a safe working condition and the environment free from toxic contaminants and pathogens. The modern day mines are now a days implementing various safety procedures and protocol, also providing training for the mine workers towards safety measures which significantly improves the work safety in mines. It is fact that working condition in underground coal is very harsh and will remain an alarming issue till fruitful attempt is made to fix them. Hence a real-time smart monitoring system capable of operating in underground mines will a befitting solution for underground miners.

In the underground mine working environment, besides "air," the ambient is mostly made up of primarily approximately 78% nitrogen and 21% oxygen. Carbon dioxide (CO<sub>2</sub>), carbon monoxide (CO), methane (CH<sub>4</sub>), nitrous oxides (NO<sub>x</sub>) and hydrogen sulfide (H<sub>2</sub>S) are five main gases that concern Workers in a coal mine [1]. As it is known that sewer gas is a complex mixture of toxic and nontoxic gases and are being produced and collected in sewage systems by the decomposition of organic household and/or industrial wastes. The major constituent of sewage gases may include hydrogen sulfide, ammonia, methane, esters, carbon monoxide, sulfur dioxide and nitrogen oxides [2].

Different types of monitoring equipment & practices are being implemented widely to access underground mine environment. The used technologies are unable to supply high spatial and temporal resolutions since it works in online mode. On-line monitoring of underground mine environment is being adopted in many advanced countries in order to improve identify & measure various environmental parameters of the underground mines. As the system uses wire communication system for sharing the environmental condition of underground mines it experiences a lot of short comings like damaging of communication cables, high fault rate, inconvenient system maintenance, etc.

In recent years, advancements in the fields of sensor technology, wireless sensor network (WSNs) and cloud computing techniques have led the way toward the development of internet of things (IoT) based solution for real-time control and monitoring actions for many real-life problems; ranging from Smart Grids automation, e-healthcare services, and home automation to environment monitoring, mine safety, etc. Advances in the big-data and data analytics and machine/ deep learning techniques have made the development of efficient real-time prediction system to support design of early warning mechanism.

The purpose of this paper is to present precursor survey leading to the design of IoT based system for ambient environment monitoring and design and early warning system to support safe working in underground mine monitoring applications. The rest of the paper is being arranged as follows: Section 2 presents an overview of background studies; Section 3 various key technologies significant for real-time monitoring of ambient air quality Section 4 precisely presents the fundamental model of the proposed system, discusses the selection of sensors, and data-analytics and machine/ deep learning techniques in brief. Finally, Section 4 presents conclusions, followed by discussions on future scope considerations.

### Back Ground Concept & Technologies Underground Mine Gases

The outer atmosphere air is a mixture of various gases. Its constitutions remains same throughout the earth surface. Instead of being a chemical substance, air is mixture hence the air components can be separated. Different type of



**Jitendra Pramanik et al.**

gases are present in underground mines having various effects on a human health. Some of the gases are flammable in nature like CO<sub>2</sub>, CO, SO<sub>2</sub>. Other impurities are also get added to the environment through blasting, underground fires, bacterial action & exhalation by mine workers. While referring to various hazardous and poisonous gases present in mines, the following are the most commonly used names:

**Blackdamp**

Carbon Dioxide is a fundamental constituent of air & significant component of Black Damp. Biological oxidation of rotting mine timbers is the primary reason creation of carbon dioxide.

**Firedamp**

Firedamp is a collection of combustible gas found in coal mines and mostly consists of methane.

**Whitedamp**

It is a noxious mixture of gases whose constituents are carbon monoxide and hydrogen sulfide .

**Stinkdamp**

It is toxic and explosive in nature & very much similar with sulphureted hydrogen (H<sub>2</sub>S).

**Afterdamp**

It is a choking gas left in mines after the explosions having rich content of carbon monoxide. It's main constituents are carbon dioxide, carbon monoxide and nitrogen. Hydrogen sulfide, another highly toxic gas, may also be present

**Existing Communication System in UG Mines**

The existing communication system in UG mines are wired in nature. These conventional system incorporates telephone magneto, pagers, sound powered telephone etc. for the purpose of communication. Telephone magnetos are the most oldest crank ringer phones which are operated by DC batteries and AC signals [10]. Pagers are basically line wired phone used for voice communication having zero potential in tracking [11]. Usage of high voltage trolley line as a carrier for voice communication is called as trolley carrier phone system. In the hoist rope system , capacitor is used as coupling device along with in order inductively coupled hoist radio signal with hoist rope. Through The Earth (TTE) system used in mines which can transmit low frequency signal to the receiver end. The loop antennas are mounted on the surface of the mines. The TTE can also provide alarming, tracking and messaging facilities [12]. For short-range communication the Ultra Wide Band (UWB) based radio system can be used with very a low power & high data rate [6-10].

The main problem for TTE communication is radio wave attenuation. The radio wave attenuation in TTE communication is basically due to the frequency of radio wave, conductivity of earth, transmission power, antenna type and noise over the surface [12-15]. In order to decrease the attenuation in the communication channel very low-frequency radio signal should be used. As per Mine Safety and Health Administration (MSHA) rules transmitting a high power signal is a very risky due to the presence of the risky conditions and noxious gases in the mine environment. In such conditions, it will be very much helpful to use helical ferrite antennas for a long range duplex voice communication and low power text messaging. Because of the low-cost & small sizes of these antennas, they can be easily mounted around the pillars present in the underground mine. These antennas are capable to provide the communication even in case of a strata failure.

The Sensor Network supporting voice communication underground mine also supports the data communication between the sensors and the their local host[16]. In recent advancement in WSN makes it possible to have bidirectional voice in real time using TDMA. These voice signals are first tamped down and then modulated with the carrier wave of suitable frequency as frequency bandwidth used in WSN is low. ZigBee is a latest wireless



**Jitendra Pramanik et al.**

technology guided by IEEE 802.15.4 Personal Area Network standard. It is basically designed for the long range controlling applications where it will be replacing the existing conventional technologies. Currently it operates in the frequency band of 868MHz at a data rate of 20Kbps in Europe, 914MHz band at 40kbps in USA, and the 2.4GHz ISM bands Worldwide at a maximum data rate of 250kbps. The WSN nodes planted in the underground regions will be collecting and sharing the data to the wireless network and following to database for further analysis.

**Gas Sensing Methods**

The Gases and vapors are always existing as fatal to the working personnel's when exceeds its beyond limits! If gases do not present in their acquainted and respirable atmospheric composition, safe breathing might be a unpredictable. Furthermore: A gas is considered to be potentially hazardous based on their concentration. Different types of gas detection system & instruments are used in order to provide adequate safety & protection to the mine workers & pant. These system are designed and developed to spot dangerous gas concentration , to give pre-alarm and to initiate counter measures.

**Gas Sensing Methods Based on Variation of Electrical Properties  
Metal Oxide Semiconductor**

The affordable cost and high sensitivity are desirable qualities which are present in metal oxide semiconductor sensors [17]. These metal oxides are splitted into two forms 1. Transition 2. Non transition. The metal oxides requires more energy as to form other oxidation. Therefore, transition-metal oxides are able to form different type of oxidation states on the surface, which can be used by metal oxide semiconductors as sensing materials, compared to the non-transition ones. Transition-metal oxides having electronic configurations  $d^0$  and  $d^{10}$  are preferably used in gas sensing applications [16]. The sensors designed with metal oxides are capable to spot combustible & oxidizing gases like  $\text{SnO}_2$ ,  $\text{CuO}$ ,  $\text{Cr}_2\text{O}_3$ ,  $\text{V}_2\text{O}_5$ ,  $\text{WO}_3$ ,  $\text{TiO}_2$  based on the change of resistance due to the presence of hazadous gases [18]. As per the discrepancy of gas concentration the resistance of  $\text{SnO}_2$  changes according (e.g., LPG, CO,  $\text{CH}_4$ ) [19,20].

**Polymers based Gas Sensing devices**

Inorganic gases and various organic compounds can shows significantly higher sensitivity in detecting poisonous & hazardous gases as compare to metal oxide semiconductors. Inorganic gases like  $\text{CO}_2$  and  $\text{H}_2\text{O}$  can be detected by using Polymer-based gas sensors.[17]. Polymer conductors which can be used as gas sensing materials includes polypyrrole (PPy), polyaniline (PAni), polythiophene (PTh) and their derivatives [21]. High sensitivities and short response times can be possible with Polymer-based gas sensors have advantages. Unlike metal oxide semiconductor based sensor, polymer-based sensors can be operated at room temperature. The low energy requirement of polymer based sensor allows their applications in battery operated safety system . Low fabrication cost, simple and portable structures, are the added benefit which encourages the use polymer based sensor [22].

**Carbon Nanotubes**

The primary disadvantage of conventional sensing materials like metal oxide semiconductors is the bad sensitivity shown at room temperature. The carbon nanotubes (CNTs) are considered to be the most material for designing of high-sensitive gas sensors. CNTs, are extensively sensitive towards a small volume of gas seen to exhibit electrical conductivity eg. carbon dioxide ( $\text{CO}_2$ ) and nitrogen oxide ( $\text{NO}_x$ ) at room temperature.

**Gas Sensing-Gas Chromatograph**

Gas Chromatography (GC) is most common method used for sensing gas in laboratories having excellent sensitivity & performance [23]. GC involves significant quantitative analytical methods like FPD & PFPD [24]. GC-OI factometry (GC-O) method [25] which combines human perception of odour and chromatographic separation of compounds, is also a branch of GC. Gas sensing through GC is very costly and more technical advancements are



**Jitendra Pramanik et al.**

needed to make it a portable application. Therefore, it is unable to meet the desired objective required by the industries.

**Electro Chemical Sensors**

The electrochemical sensor just works like a battery, as it produces electron in the presence of toxic gases. It is called as a micro-reactor. The concentration of gases are measure in terms of electric current. It comprises of two electrodes having electrical contact is two separate ways : 1. Using an electrical conductive medium called electrolyte 2. Through an outer electric current circuit. In order to operate the electrochemical sensor a very low electric power is required which is intrinsically within the safe limit.

**Proposed System**

Wireless Sensor Networks (WSN) has emerged as a base component for the realization of vital real-life solutions in IoT framework. WSN is a useful technology viable for the collection gaseous parameters in real-time from the mine work environment. Basically, the sensor network comprises of number of sensor nodes fitted with variety of sensor placed at different locations and communicate with each other. Topology for the base network architecture and protocol employed for the realization of the WSN plays a vital role in implementing a specific method of communication [32] and defines the way in which data is sent around the network. The two popular topologies are mesh and star network topologies. Further, a mesh topology can be a full mesh or partially connected mesh topology. In a full mesh topology, every computer in the network has a connection to each of the other computers in that network while in a partially connected mesh topology, at least two of the computers in the network have connections to multiple other computers in that network. The star topology, each node in the network is connected to a hub or central node forcing each node to communicate with this central hub directly. The topology for the proposed WSN based Mine Safety Network (MSN) is as shown in the figure-1 below.

**Key components in the MSN are**

1. MSN Sensor Node – that attaches variety of sensors units to the SBC which communicates the data to the MSN Gateway Node. MSN Sensor Nodes comprise of multiple Sensor Node modules, battery lifetime monitoring and sensing mechanism, etc. all connected to each other with the help of non-IP based network connectivity over radio links.
2. MSN Gateway Node – that receives the environmental gas concentration data being transmitted by the MSN Sensor Nodes, received through connectivity established over non-IP based network and forwarding the information for remote monitoring and implement various analytics through some open source cloud platform through connectivity established over traditional IP based network, where security enforcement is carried out with the help of some lightweight messaging protocol for small sensors and mobile devices, optimized for high-latency or unreliable networks, like MQTT (Message Queuing Telemetry Transport) – an ISO standard publish-subscribe-based messaging protocol, which works on top of the regular TCP/IP protocol and is designed for connections with remote locations where a "small code footprint" is required (WSN of resource constrained devices) or the network bandwidth is limited (Low Power Radio Networks).
3. Sensor Data Repository deployed in some Open Cloud IoT Platforms, like ThingSpeak, DeviceHive, Thinger.io, Kaa IoT Platform, The Things Network (TTN), Distributed Services Architecture (DSA), etc.
4. Remote Monitoring Stations – these are variety of autonomous end device; mostly deployed as applications in the devices ranging from Desktop PCs to Laptop, PDAs, Smartphones, etc., and runs appropriate applications to retrieve sensor data from the cloud based sensor data repository. Shown in Figure-2 below.

The objective of this paper is to present an outline of the design of a proposed Mine Safety Network (MSN) for an underground coal mine to assess, monitor and measure the presence of poisonous and hazardous mine gases based on the outcome of study various industrial parameters. A functional model of the WSN based Mine Safety Network



**Jitendra Pramanik et al.**

operating in IoT Framework can be depicted with the help of following Figure 1. The data repository deployed with the help of some open source IoT Platforms, such as ThingSpeak, DeviceHive, Thinger.io, Kaa IoT Platform, The Things Network (TTN), Distributed Services Architecture (DSA), etc.

The proposed work will employ real-time data analytics to ensure serving timely insight into the monitoring of environmental conditions. Integrating ML techniques with real-time data analysis of the ambience data combined with other vital environmental parameters, such as temperature, humidity and pressure can help in providing vital indications of many issues that otherwise would have arrived without notice. Real-time analytics with ML techniques will ensure automated response to many crucial catastrophes and emergency situations.

**CONCLUSION**

In general, the conventional systems of monitoring condition of the mine including mine atmosphere and mine equipment are associated with personal observation and intermittent readings and offline analysis of the data. A person goes to the mine working place (for gas analysis, load on supports, electrical parameters of mining equipment to assess the machine condition etc.) and then these readings are analyzed offline. This time taking process is performed in different shifts and has to carefully note down the readings. Therefore, for improved evaluation of mine conditions, wireless systems may be applied for online monitoring of the mine atmosphere, and equipment including supports-hydraulic props, chock shields, loading and cutting equipment and associated machinery. The study of may remote monitoring of UG mining gases lead to autonomous decision in real time using ambient intelligence which provide better results than through common decision making based on intermittent tests and conventional procedures of sample collection and analysis in the laboratory. Emphasis is made on urgent requirement of application of trans-disciplinary research and study the underground mine conditions including online monitoring of mine atmosphere and mine equipment by application of wireless sensor networks and IoT devices.

**REFERENCES**

1. Mine Gases - IMRC 2016, <http://www.imrc2016.ca/UserFiles/ContentPages/Mine%20Gases.pdf>
2. Sewer gas, [https://en.wikipedia.org/wiki/Sewer\\_gas](https://en.wikipedia.org/wiki/Sewer_gas)
3. Cheekiralla Sivaram M. S. L(2001)"Development of a wireless sensor unit for tunnel monitoring", Master of Science in Civil and Environmental Engineering Thesis, Massachusetts Institute of Technology
4. Tan, W., Wang, Q., Huang, H., Guo, Y., Zhang, G. (2007), "Mine Fire Detection System Based on Wireless Sensor Network
5. Li, W., Li, Z., Liu, W., Wei, P. (2009), "The remote monitoring and analysis system of mine safety based on virtual instrument
6. Xiaodong, Z., Yuegang, T., Yan, H. (2014), "Research and Application of Embedded Technology in Remote Network Monitoring System of Coal Mine
7. Bin, G., Huizong, L. (2011), "The research on ZigBee-based Mine Safety Monitoring System"
8. Boddu, R., Balanagu, P., Babu, N.S. (2012), " Zigbee based mine safety monitoring system with GSM".
9. Kumar, M., Sharma, M., Narayan, R., Joshi, S., Kumar, S. (2013), " Zigbee based parameter monitoring and controlling system for induction machine
10. Kumarsagar, Dange, M., Patil, R.T. (2013), "Design of Monitoring System for Coal Mine Safety Based on MSP430
11. Bandyopadhyay, L. K., Chaulya, S. K., & Mishra, P. K. (2010). *Wireless Communication in Underground Mines*, Springer Publication, 1-50, 88,102,117,135.



**Jitendra Pramanik et al.**

12. Underground Mine Communication (in four parts):2. Paging system/compiled by staff- mining research, Pittsburgh Mining and Safety Research Centre. [Washington]: United States Department of the Interior, Bureau of Mines, 1977.
13. B Austin, B. A. (1990, October). Medium frequency body loop antenna for use underground. In *Electrically Small Antennas, IEE Colloquium on* (pp. 3-1). IET.
14. Foerster, J. (2002). Ultra-wideband technology for short-range, high-rate wireless communications. *internet presentation, <http://www.ieee.or.com/Archive/uwb.pdf>*.
15. Foerster, J., Green, E., Somayazulu, S., & Leeper, D (2001). Ultra-Wideband Technology for Short-or Medium-Range Wireless Communications. In *Intel Technology Journal*.
16. Molisch, A. F. (2005). Ultrawideband propagation channels-theory, measurement, and modeling. *Vehicular Technology, IEEE Transactions on*,54(5), 1528-1545.
17. Hamalainen, M., Talvitie, J., Hovinen, V., & Leppanen, P. (1998, September). Wideband radio channel measurement in a mine. In *Spread Spectrum Techniques and Applications, 1998. Proceedings., 1998 IEEE 5th International Symposium on* (Vol. 2, pp. 522-526). IEEE.
18. Chung, K. S. (2000). A radio communications network for voice and data in underground mines. In *TENCON 2000. Proceedings* (Vol. 1, pp. 516-521). IEEE.
19. Liu, Xiao, Sitian Cheng, Hong Liu, Sha Hu, Daqiang Zhang, and Huansheng Ning. "A survey on gas sensing technology." *Sensors* 12, no. 7 (2012): 9635-9665.
20. Batzill, M.; Diebold, U. The surface and materials science of tin oxide. *Prog. Surf. Sci.* 2005, 79, 47–154. [Google Scholar]
21. Hoefler, U.; Böttner, H.; Felske, A.; Kühner, G.; Steiner, K.; Sulz, G. Thin-film SnO<sub>2</sub> sensor arrays controlled by variation of contact potential-A suitable tool for chemometric gas mixture analysis in the TLV range. *Sens. Actuators B* 1997, 44, 429–433. [Google Scholar].
22. Endres, H.E.; Göttler, W.; Hartinger, R.; Drost, S.; Hellmich, W.; Müller, G.; Braunmühl, C.B.; Krenkow, A.; Perego, C.; Sberveglieri, G. A thin-film SnO<sub>2</sub> sensor system for simultaneous detection of CO and NO<sub>2</sub> with neural signal evaluation. *Sens. Actuators B* 1996, 36, 353–357
23. Bai, H.; Shi, G. Gas sensors based on conducting polymers. *Sensors* 2007, 7, 267–307.
24. Munoz, B.C.; Steinthal, G.; Sunshine, S. Conductive polymer carbon black composites-based sensor arrays for use in an electronic nose. *Sens. Rev.* 1999, 19, 300–305.
25. Kim, K.H. Performance characterization of the GC/PFPD for H<sub>2</sub>S, CH<sub>3</sub>SH, CH<sub>3</sub>SCH<sub>3</sub>, and CH<sub>3</sub>SSCH<sub>3</sub> in air. *Atmos. Environ.* 2005, 39, 2235–2242.
26. Catalan, L.J.J.; Liang, V.; Jia, C.Q. Comparison of various detection limit estimates for volatile sulphur compounds by gas chromatography with pulsed flame photometric detection. *J. Chromatogr. A* 2006, 1136, 89–98.
27. Rolf H. Weber, "Internet of Things New security and privacy challenges", *Computer Law and Security Review*, Elsevier Journal, Volume 26, Issue 1, pp 23-30, January 2010.
28. Ashwini Doni, Chidananda Murthy M. V., Dr M.Z. Kurian, "Survey on multi sensor based air and water quality monitoring using IoT", *Indian J. Sci. Res.* 17(2): 147-153, 2018
29. Michael Huff, "MEMS: An enabling technology for the internet of things (IoT)", *Internet of Things and Data Analytics Handbook*, Chapter 9, Published by John Wiley & Sons, Inc., pp. 147-166, February 2017.
30. JackW Judy, "Microelectromechanical systems (MEMS): Fabrication, design and applications", *Smart Materials and Structures*, Institute of Physics Publishing, Vo. 10, pp. 1115–1134, November 2001.





**Jitendra Pramanik et al.**

31. Gastone Ciuti, Leonardo Ricotti, Arianna Menciasci and Paolo Dario, "MEMS Sensor Technologies for Human Centred Applications in Healthcare, Physical Activities, Safety and Environmental Sensing: A Review on Research Activities in Italy", *Sensors*, Vol. 15, pp. 6441-6468, 2015
32. Supervised and Unsupervised Machine Learning Algorithms, <https://machinelearningmastery.com/supervised-and-unsupervised-machine-learning-algorithms/>
33. Valdo Henriques and Reza Malekian, Mine Safety System Using Wireless Sensor Network, *IEEE Access*, Volume 4, pp. 3511-3521, 2016
34. Van Ruth, S.M. Evaluation of two gas chromatography-olfactometry methods: The detection frequency and perceived intensity method. *J. Chromatogr. A* 2004, 1054, 33-37.

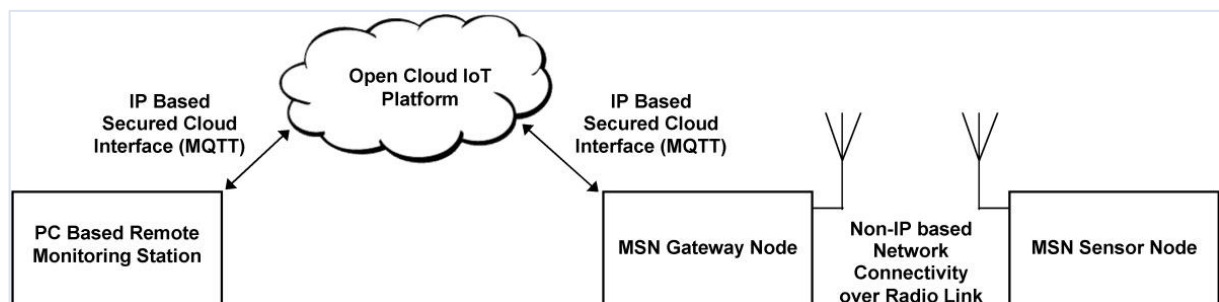

**Figure 1. Functional Model of the WSN based Mine Safety Network operating in IoT Framework**

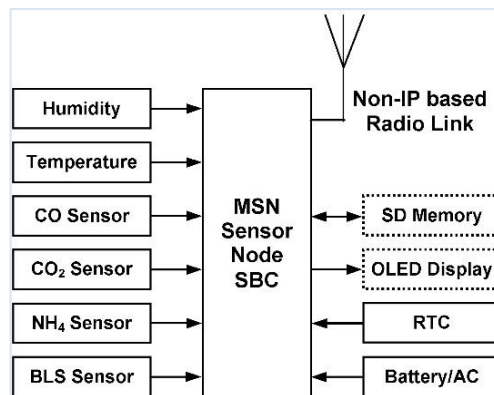

**Figure 2. Functional Model of the MSN Sensor Node**





## ***In vivo* Anti-Diabetic Activity of the Ethanolic Crude Extract of *Vallisneria spiralis* Leaves**

P. Pandian

Associate Professor, Department of Pharmacy, Annamalai University, Annamalainagar, TamilNadu India.

Received: 19 Jan 2020

Revised: 22 Feb 2020

Accepted: 25 Mar 2020

### **\*Address for Correspondence**

**P. Pandian**

Associate Professor,  
Department of Pharmacy,  
Annamalai University, Annamalainagar,  
TamilNadu India.

Email: pandian0071@rediffmail.com



This is an Open Access Journal / article distributed under the terms of the **Creative Commons Attribution License** (CC BY-NC-ND 3.0) which permits unrestricted use, distribution, and reproduction in any medium, provided the original work is properly cited. All rights reserved.

### **ABSTRACT**

Diabetes is a metabolic disorder that causes deficiency in insulin. The insulin is secreted by pancreas lies next to stomach it makes glucose get into our bodies. When diabetes occurs to our body it cannot enough to produce insulin or cannot use its own insulin as well as it should. In this study the plant *Vallisneria spiralis* leaves were collected from in and around of Tirunelveli district, the ethanol extract is used for the studies. 30 rats are used for the study in which 6 rats are divided into five groups, the Streptozotocin 50mg/kg.b.wt used to induce diabetic in rats. The studies reveal about the blood glucose in fasting and postprandial levels it shows normal when the blood glucose levels were compared to the standard and biochemical parameters like serum cholesterol, serum triglycerides, serum HDL, serum LDL, serum creatinine, serum urea are estimated in the extract. The extract shows the normal when compared to the standard metformin. The two-dose level was used ie low dose 250mg/kg and 500mg/kg.

**Keywords :** Diabetes, Ethanol, Metformin, Streptozotocin *Vallisneria spiralis*.

### **INTRODUCTION**

It is a micro and macro vascular complications of metabolic disorders with more significant in morbidity and mortality.it is fifth death causes in the world when compare to other disease. To cure diabetes in modern medicine there is no satisfactory effective therapy was not available. (1) the food which we take converted into glucose or energy to utilized in the body, in diabetes the condition was that the processed food not properly used as energy into the body. The insulin is secreted by pancreas lies next to stomach it makes glucose get into our bodies. (2) when diabetes occurs to our body it cannot enough to produce insulin or cannot use its own insulin as well as it should.







## Pandian

This make more sugars in the blood, due to this the peoples are referring to us diabetes. The heart disease, blindness, kidney failure and lower extremity amputations are all some complications due to diabetes. The Ebers papyrus of about 1550 B.C. the medicinal plants for the treatment of diabetes was used and described throughout the world. (3)

The useful source of medicinal plants provides for the oral hypoglycemic compounds for the dietary supplement and as well for the development of new leads to the pharmaceuticals existing therapies. (4) As per Indian populations shows the higher age related to prevalence of diabetes when compared to the other countries populations. (5) For a given BMI, Asian Indians display a higher insulin level which is an indicator of peripheral insulin resistance. Due to higher body fat percentage the Indians are resistance to insulin. (6,7) Excess body fat, typical abdominal deposition pattern, low muscle mass, and racial predisposition may explain the prevalence of hyperinsulinemia and increased development of type 2 diabetes in Asian Indians. According to the World Health Organization (WHO), up to 90% of the population in developing countries uses plants and its products as traditional medicine for primary health care. (8) The WHO has listed 21,000 plants, which are used for medicinal purposes around the world. Among these, 2500 species are in India. (9) There are about 800 plants which have been reported to show antidiabetic potential. (10) In the treatment of diabetes, the numerous bioactive compound principles representing in plant derived collection are established.

## MATERIALS AND METHODS

### Plant Details

In the world checklist of selected plant families developed by the royal botanical gardens at Kew, England, a total of 28 botanical names of *Vallisneria* species have been listed under the family Apocynaceae of which only *Vallisneria spiralis*, *Vallisneria spiralis* and *Vallisneria spiralis* are accepted names. (11) The *Vallisneria spiralis* (Roth) Kuntze is a climbing shrub often twining and can grow up to 10m tall. (12) leaves are elliptic and densely pubescent on both surfaces flowers are creamy white fragrant with borne in clusters. The species occurs naturally along stream banks in forests of south and Southeast Asia. Traditionally the milky latex of *V.solanacea* can be applied to treat ringworm and other skin infections including sores, cuts and wounds. (13,14).

### Extraction Procedure

#### Collection and Processing of Plant Material

The leaf of *Vallisneria spiralis* was collected in and around of Tirunelveli district. The collected plant material was washed with tap water for 3 times and sterilized by spraying with 70% alcohol. The sterilized plant material was shade dried at room temperature to avoid chemical changes and frequently observed for any fungal contamination as the plant material rich in water content. When the plant material was completely dried it is subjected to prepare fine powder with the help of pestle and motor. The fine powder is collected and used for extraction of crude drug in ethanol solvents by Soxhlet extraction method.

#### Extraction by Soxhlet apparatus

The extraction procedure for the isolation of crude drug from plants has been practiced since long time. The precise mode of extraction naturally depends on the texture and water content of the plant material being extracted and on type of substance that is being isolated. Normally the crude extract is taken from Soxhlet apparatus with the Ethanol solvent. This apparatus mainly consists of three parts, round bottom flask in which the solvent is taken, main jar in which material from which the compounds to be extracted is kept loaded and condenser in which condensation of vapors of solvents takes place. 200 g of the powder of plant material from which the extract has to be taken is packed into Soxhlet main jar. The solvent is poured into the round bottom flask and extract condensation under reduced





## Pandian

pressure and controlled temperature of 60-80°C is set to boil through regulated heating mantle. The vapor of the solvent pass through drive tubes, enter the condenser through the main jar and get condensed where there is continuous flow of water in the condenser. The condensed solvent falls back on the packed material in the main jar before collecting in jar itself. The collection and extraction of material takes place simultaneously in the main jar as seen by the coloring of the solvent as compound of material get dissolved in the solvent. Thus, the crude extract of the plant material is obtained and normally it takes 7-8 hours for complete an extraction. The solvent will be evaporated and finally it yields green extract, this is stored in refrigerator for further usage.

### Experimental animals

Adults male wistar rats 30 (weighing 150-200g) was used for the investigation. Before starting of the experiment, the animals are trained in laboratory conditions for a period of two weeks. They were maintained at an ambient temperature (25±2 0 c) and relative humidity (40-60%) with 12/12hrs of light/dark cycle and all the experiments carried as per the Annamalai University Institutional Animal Ethics Committee proposal number AU-IAEC/1232/1/19

### Induction of Diabetes in Rats

Streptozotocin is used to induce diabetes in rats. Diabetes will be induced by injecting a dose of 50mg/kg (15) of Streptozotocin at intraperitoneally. The blood sample was collected from the tail vein and retro-orbital plexus, after 48hrs fasting, blood glucose levels as well as glycosuria was tested to confirm the diabetic state. Only rats with fasting blood glucose level of at least 250mg/dl is considered diabetic.

### Experimental design

Animals was divided into five groups of six animals each

Group I : Normal control

Group II : Diabetic control (Streptozotocin 50mg/kg.b.wt)

Group III : Diabetic rats received 250mg/kg of *Vallis solanacea* Ethanol extract (orally)

Group IV : Diabetic rats received 500mg/kg of *Vallis solanacea* Ethanol extract (orally) (16)

Group V : Diabetic rats received Standard drug Metformin (100mg/kg .b.wt)

### Study protocol

All 5 groups of rats on 1 st day and 14 th days blood was collected. The parameter like blood glucose level for fasting and post prandial, biochemical parameters are observed and tabulated.

### Statistical analysis

All the results were expressed as Mean ± SEM. Student's t-test was used to assess statistical significance in all groups of animals.

## RESULT

The ethanol leaves extract of *Vallis solanacea* are subjected to antidiabetic activity in albino rats, where in streptozotocin was used as the diabetogenic agent. The mean ± SEM Fasting blood glucose level in normal control rats was on 1st day 89.8±1.52 and 14th day was 80.8±1.30. A marked increase in blood glucose level was seen in diabetic control group. Whereas metformin treated group shows progressive decrease in blood glucose levels at 1st



**Pandian**

day  $192.1 \pm 3.14$  and on 14<sup>th</sup> day  $87.8 \pm 2.47$ . The high dose of extract was reduced the fasting blood glucose level at 1st day  $177.5 \pm 2.58$  and on 14th day was  $102.5 \pm 2.76$  and in low dose of extract was significantly reduced blood glucose level at 1st day  $167 \pm 2.52$  and at 14th day was  $106.6 \pm 2.19$ . The table 1 and graph 1 shows a reduction in fasting blood glucose levels in both metformin and extract treated group i.e. low and high dose of extract when compared with diabetic control group. The post prandial blood glucose is given in the Table 2 and graph 2. The 1st day the extract of low and high dose was slightly increased when compared to diabetic control and 14th day the blood glucose level for low and high dose of extract was decreased when compared to the diabetic control.

**Biochemical Parameters****Serum cholesterol**

A marked rise in serum cholesterol levels was seen in diabetic control group that was  $242.6 \pm 5.55$ . Where low dose of extract group has shown a decrease in serum cholesterol  $180.1 \pm 12.9$  and high dose of extract group has shown a decrease in serum cholesterol  $157.6 \pm 2.09$ . Whereas the standard has shown a decrease in serum cholesterol  $153.8 \pm 2.96$

**Serum triglycerides**

A marked rise in serum triglycerides levels was seen in diabetic control group that was  $164.8 \pm 5.74$ . Where low dose of extract group has shown a decrease in serum triglycerides  $131.1 \pm 2.80$  and high dose of extract group has shown a decrease in serum triglycerides  $106.8 \pm 4.54$ . Whereas the standard has shown a decrease in serum triglycerides  $98.3 \pm 1.20$ .

**Serum HDL**

A marked rise in serum HDL levels was seen in diabetic control group that was  $68.0 \pm 0.57$ . Where low dose of extract group has shown a decrease in serum HDL  $48.5 \pm 1.67$  and high dose of extract group has shown a decrease in serum HDL  $53.3 \pm 0.95$ . Whereas the standard has shown a decrease in serum HDL  $54.6 \pm 1.33$ .

**Serum LDL**

A marked rise in serum LDL levels was seen in diabetic control group that was  $167.8 \pm 3.10$ . Where low dose of extract group has shown a decrease in serum LDL  $130.6 \pm 1.86$  and high dose of extract group has shown a decrease in serum LDL  $99.6 \pm 3.26$ . Whereas the standard has shown a decrease in serum LDL  $98.5 \pm 1.77$ .

**Serum creatinine**

A marked rise in serum creatinine levels was seen in diabetic control group that was  $1.31 \pm 0.04$ . Where low dose of extract group has shown a decrease in serum creatinine  $0.54 \pm 0.03$  and high dose of extract group has shown a decrease in serum creatinine  $0.73 \pm 0.02$ . Whereas the standard has shown a decrease in serum creatinine  $0.68 \pm 0.02$ .

**Serum urea**

A marked rise in serum urea levels was seen in diabetic control group that was  $67.8 \pm 2.15$ . Where low dose of extract group has shown a decrease in serum urea  $46.5 \pm 3.18$  and high dose of extract group has shown a decrease in serum urea  $46.33 \pm 2.65$ . Whereas the standard has shown a decrease in serum urea  $37.6 \pm 1.40$ .

**DISCUSSION**

The antidiabetic activity of *Vallisneria spiralis* was assessed by monitoring the blood glucose levels and change in body weight in diabetic animals at particular time interval i.e. on the 1st and 14<sup>th</sup> days of treatment. Other parameters like serum cholesterol, serum triglycerides, serum HDL, serum LDL, and serum creatinine and serum urea were also noted and shown in the Table 3 and graph 3. The extract showed the significant activity which was compared with standard drug. There is a decrease in blood glucose level on 14th day of treatment, this result revealed a well-defined



**Pandian**

role of herbal drug in suppressing the glucose level in diabetes. Streptozotocin has known to induce diabetes mellitus in experimental animals which may be due to hyperglycemia. This study shows that the herbal extract can reverse this effect.

The possible mechanism by which this extract brings about its hypoglycemic action may be by potentiating the insulin effects of plasma by increasing either the pancreatic secretion of insulin from  $\beta$ -cells of islets of Langerhans or its release from the bound form. The biochemical parameters were decreased significantly but the serum HDL level was increased by the standard metformin and ethanol extract after 14th days of treatment, higher level of HDL cholesterol protect the heart from heart problem like heart attack, stroke etc. In this study the combination of metformin and extract was found more effective in lowering both fasting and post prandial blood glucose levels it is due to presence of different types of active phytochemicals, which may have different mechanism of action, Metformin is widely prescribed for humans with Type 2 diabetes in the world. (17) It is able to inhibit hepatic glucose production and also acts as an insulin sensitizer in isolated skeletal muscle from insulin-resistant humans. (18) It was demonstrated that the enzyme AMP-activated kinase (AMPK) is activated by metformin. (17–21) AMPK is a key sensor of cell energetic balance being activated by increase in the ratio AMP/ATP.

There are indications that the activation of this enzyme is beneficial for the treatment and prevention of Type 2 diabetes and the metabolic syndrome (21–23) its activation leads to increased glucose uptake in rat skeletal muscle. (24) Likewise, the ethanol crude extract of *Vallisneria spiralis* increases glucose uptake in C2C12 cells by means of AMPK activation, which appears to implicate the inhibition of mitochondrial respiration. (25) These cellular and molecular actions may thus play a significant role in the hypoglycemic activity of the plant in vivo. The ethanol extract of *Vallisneria spiralis* leaves exhibited significant hypoglycemic properties. However further experiments are required to identify the active molecules, to elucidate the effect of extract on insulin and in need of human trials for its confirmation into the use of humans.

**REFERENCES**

1. N.Ravi Babu, studies on the evaluation of antidiabetic and antioxidant activities using some selected medicinal plant. International Journal of Herbal Medicine 2016; 4(2):21-24.
2. Grover JK, Yadav S, Vats V. Medicinal plants of India with antidiabetic potential J.Ethanopharmacology. 2002; 81(1):81-100.
3. Kesari AN, Gupta RK, Watal G. Hypoglycemic effects of *Murraya koenigii* on normal and alloxan diabetic rabbits. J. Ethnopharmacol., 2005;11: 223–231.
4. Bailey CJ, Day C. Traditional plant medicines as treatments for diabetes. Diabetes Care, 1989;12: 553–564.
5. M. K. Ali, K. M. V. Narayan, and N. Tandon, "Diabetes & coronary heart disease: current perspectives," Indian Journal of Medical Research, 2010; 132(11): 584–597.
6. M. A. Banerji, N. Faridi, R. Atluri, R. L. Chaiken, and H. E. Lebovitz, "Body composition, visceral fat, leptin, and insulin resistance in Asian Indian men," Journal of Clinical Endocrinology and Metabolism, 1999; 84(1) :137–144.
7. V. Dudeja, A. Misra, R. M. Pandey, G. Devina, G. Kumar, and N. K. Vikram, "BMI does not accurately predict overweight in Asian Indians in northern India," British Journal of Nutrition, 2001;86(1) :105–112.
8. World Health Organization, "Traditional medicine-growing needs and potential," WHO Policy Perspective on Medicines, 2002; 2 :1–6.
9. M. Modak, P. Dixit, J. Londhe, S. Ghaskadbi, and T. P. A. Devasagayam, "Indian herbs and herbal drugs used for the treatment of diabetes," Journal of Clinical Biochemistry and Nutrition, 2007; 40(3) : 163–173.
10. R. Patil, R. Patil, B. Ahirwar, and D. Ahirwar, "Current status of Indian medicinal plants with antidiabetic potential: a review," Asian Pacific Journal of Tropical Biomedicine, 2011; 1(2) : S291–S298,





### Pandian

11. WCPS. Vallaris. Royal Botanic Gardens, Kew; World checklist of selected plant Families. Pharmacognosy Journal.2013;5:242-246.
12. Li B, Leeuwenberg AJM, Middelton DJ. Vallaris Flora china1995; 16:177.
13. Ahmed F, Sadhu SK Ishibashi M. Search of bioactive natural products from medicinal plants of Bangladesh. Journal of Nat Medicine.2010; 64:393-401.
14. Karmakar KU, Ghosh D, Sadhu SK. Assessment of analgesic, cytotoxic and antioxidant activities of Vallaris solanacea (Roth) Kuntze. Stamford Journal of Pharm Sci. 2011; 4:64-68.
15. S.K. Das, P. V Pansuriya, S. T Shukla, K. J Gohil, S. P Roy, A.Choudhury, V.N Sutariya. Preclinical evaluation of Vallaris solanacea (Roth) Kuntze stem for its antiulcer and antioxidant activity in wistar albino rats. Oriental Pharmacy and Experimental Medicine. 2014; 14: 7-13.
16. P.Kemasari S.Sangeetha, P.Venkatalakshmi. Antihyperglycemic activity of *Mangifera indica* Linn. in alloxan induced diabetic rats. Journal Chem.Pharm.Res.2011;3(5):653-659.
17. N. Musi, M. F. Hirshman, J. Nygren et al., "Metformin increases AMP-activated protein-kinase activity in skeletal muscle of subjects with type 2 diabetes," Diabetes, 2002; (51)7:2074–2081.
18. S. A. Hawley, A. E. Gadalla, G. S. Olsen, and D. G. Hardie, "The antidiabetic drug metformin activates the AMP-activated protein kinase cascade via an adenine nucleotide-independent mechanism," Diabetes, 2002;51: 2420–2425.
19. M.-H. Zou, S. S. Kirkpatrick, B. J. Davis et al., "Activation of the AMP-activated protein kinase by the anti-diabetic drug metformin in vivo: role of mitochondrial reactive nitrogen species," Journal of Biological Chemistry, 2004; 279 (42) :43940–43951.
20. A. E. Kitabchi, M. Temprosa, W. C. Knowler, S. E. Kahn, S. E. Fowler, S. M. Haffner et al., "The Diabetes Prevention Program Research Group. Role of insulin secretion and sensitivity in the evolution of type 2 diabetes in the diabetes prevention program: effects of lifestyle intervention and metformin," Diabetes, 2005; 54:2404–2414.
21. D. G. Hardie, "Minireview: the AMP-activated protein kinase cascade: the key sensor of cellular energy status," Endocrinology, 2003;144(12) :5179–5183.
22. L. G. D. Fryer, A. Parbu-Patel, and D. Carling, "The anti-diabetic drugs rosiglitazone and metformin stimulate AMP-activated protein kinase through distinct signaling pathways," Journal of Biological Chemistry, 2002; 277(28) :25226–25232.
23. G. Zhou, R. Myers, Y. Li et al., "Role of AMP-activated protein kinase in mechanism of metformin action," Journal of Clinical Investigation, 2001;08(8) :1167–1174.
24. M. Zang, A. Zuccollo, X. Hou et al., "AMP-activated protein kinase is required for the lipid- lowering effect of metformin in insulin-resistant human HepG2 cells," Journal of Biological Chemistry, 2004;279(46) :47898–47905.
25. A. D. Spoor, L. C. Martineau, J. T. Arnason, and P. S. Haddad, "Mechanisms of anti-diabetic activity of extracts of selected medicinal plant species of the Canadian boreal forest," Diabetes Research and Clinical Practice, 2007; 4:156.

**Table 1. Data showing fasting blood glucose levels at different time intervals**

Groups	Treatment	Fasting blood glucose level (mg/dl)	
		1 <sup>st</sup> day	14 <sup>th</sup> day
I	Normal control	89.8 ± 1.52	80.8±1.30
II	Diabetic control	154.6± 2.62	186.1±2.01
III	250mg/kg of <i>Vallaris solanacea</i> Ethanol extract	167±2.52	106.6±2.19
IV	500mg/kg of <i>Vallaris solanacea</i> Ethanol extract	177.5±2.58	102.5±2.76
V	Standard drug Metformin (100mg/kg .b.wt)	192.01±3.14	87.8±2.47





**Pandian**

**Table 2. Data showing Post Prandial blood glucose levels at different time intervals**

Groups	Treatment	Blood glucose level (mg/dl)	
		Initial Value	Final Value
I	Normal control	94.1 ± 1.79	98.1±2.00
II	Diabetic control	162.8±3.14	193.8±2.22
III	250mg/kg of <i>Vallis solanacea</i> Ethanol extract	174.5±3.49	122±2.27
IV	500mg/kg of <i>Vallis solanacea</i> Ethanol extract	187.1±2.58	103.5±2.47
V	Standard drug Metformin (100mg/kg .b.wt)	199.08±2.90	92.1±1.81

**Table 3. Data showing bio-chemical parameters after 14 days of treatment**

Data showing bio-chemical parameters after 14 days of treatment mean ±SEM							
Groups	Treatment	Serum cholesterol	Serum triglycerides	Serum HDL	Serum LDL	Serum creatinine	Serum urea
I	Normal control	148.8±3.71	82±5.49	50.5±3.00	91±2.89	0.54±0.03	41.6±3.50
II	Diabetic control	242.6±5.55	164.8±5.74	68.0±0.57	167.8±3.10	1.31±0.04	67.8±2.15
III	Low dose of extract	180.1±12.9	131.1±2.80	48.5±1.67	130.6±1.86	0.54±0.03	46.5±3.18
IV	High dose of extract	157.6±2.09	106.8±4.54	53.3±0.95	99.6±3.26	0.73±0.02	46.33±2.65
V	Standard Metformin	153.8±2.96	98.3±1.20	54.6±1.33	98.5±1.77	0.68±0.02	37.6±1.40



**Figure 1. Vallaris solanacea Leaves**

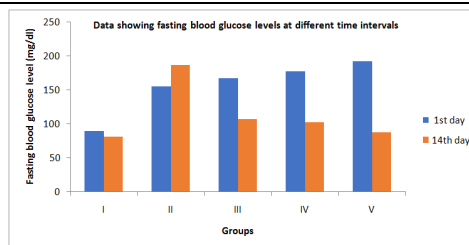

**Figure 2. Data showing fasting blood glucose levels at different time intervals**

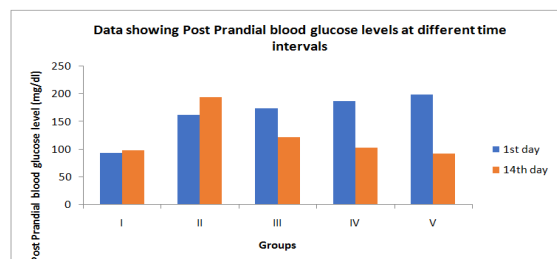

**Figure 3. Data showing Post Prandial blood glucose levels at different time intervals**

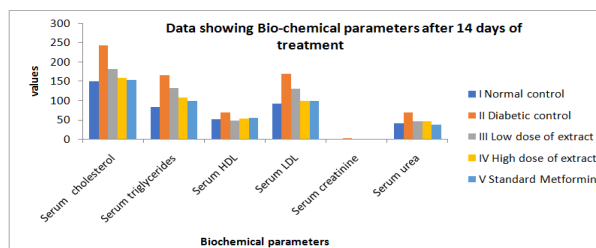

**Figure 4. Data showing bio-chemical parameters after 14 days of treatment**





## Superposition Modulation and its Power Distribution Method

Shibashis Pradhan<sup>1\*</sup>, Subhraraj Panda<sup>2</sup> and Prabhat Kumar Patnaik<sup>1</sup>

<sup>1</sup>Department of Electronics and Communication Engineering, Centurion University of Technology and Management, Bhubaneswar, Odisha, India

<sup>2</sup>Department of Physics, Centurion University of Technology and Management, Bhubaneswar, Odisha, India

Received: 21 Jan 2020

Revised: 23 Feb 2020

Accepted: 25 Mar 2020

### \* Address for Correspondence

#### Shibashis Pradhan

Department of Electronics and Communication Engineering,  
Centurion University of Technology and Management,  
Bhubaneswar, Odisha, India.

Email: shibashispradhan@gmail.com



This is an Open Access Journal / article distributed under the terms of the **Creative Commons Attribution License** (CC BY-NC-ND 3.0) which permits unrestricted use, distribution, and reproduction in any medium, provided the original work is properly cited. All rights reserved.

### ABSTRACT

Superposition Modulation (SM) is a novel mapping technique that uses linear superposition to load binary digits onto finite number of alphabet symbols that are suitable for signal transmission. SM performs superior compared to bit-interleaved coded modulation with PSK or QAM. It is an alternative to signal shaping for approaching the channel capacity in the high SNR case. SM has been examined with different power allocation schemes namely Equal Power Allocation (EPA), Unequal Power Allocation (UPA) and Grouped Power Allocation (GPA) for capacity achievement.

**Keywords :** EPA, UPA, GPA, PSM, IDM, BICM, LDHC.

## INTRODUCTION

Shannon's information theory states that, the capacity of a Gaussian channel can be achieved if and only if the channel outputs are Gaussian distributed [1-2]. The channel outputs can only be Gaussian if the channel inputs have a distribution with a Gaussian-like envelope in case of high SNR. Thus, conventional uniform mapping schemes are no longer suitable. The characteristic feature of SM is that the conversion from binary digits to symbols is done by a certain form of linear superposition instead of bijective mapping. Due to linear superposition, the symbol distribution can be as Gaussian as desired. On the other hand, superimposed components interfere with each other, and the resulting relationship between bit tuples and symbols is often non-bijective. As a result, SM shows many features relating to conventional uniform mapping schemes. Equal power allocation (EPA) provides excellent power efficiency but comes with a limited bandwidth efficiency for a reasonable superposition order. On contrary, unequal power allocation (UPA) provides a high bandwidth efficiency but a degraded power efficiency. The drawbacks of

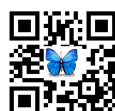



**Shibashis Pradhan et al.**

EPA and UPA has been eliminated ba novel scheme called grouped power allocation (GPA) is proposed. SM-GPA delivers a significantly improved bandwidth efficiency compared to SM-EPA but does not degrade the achievable power efficiency like SM-UPA.

**Superposition Mapping**

The general structure of superposition mapping has been represented in Fig 1. After Serial-to-Parallel (S/P) conversion, the  $N$  input code bits are converted into binary antipodal symbols  $d_n$  using Binary Phase Shift Keying (BPSK). The finite-alphabet out symbols are obtained using linearly superimposed symbols after amplitude allocation. This mapping procedure may be mathematically expressed as in equation (3)

$$x = \sum_{n=1}^N c_n = \sum_{n=1}^N \alpha_n d_n = \sum_{n=1}^N \alpha_n (1 - 2b_n),$$

$$\alpha_n \in R, b_n \in \{0,1\}$$

where  $\alpha_n$  is the magnitude of the  $n^{th}$  binary chip. The set of magnitudes  $\{\alpha_1, \alpha_2, \alpha_3, \dots, \alpha_n\}$  specifies the power allocation among the superimposed chips. Power allocation significantly impacts the acceptable bandwidth efficiency and the achievable power efficiency.

**Equal Power Allocation (EPA)**

Equal Power Allocation (EPA) is the simplest yet the most vital power allocation strategy for SM. The chip amplitudes are all alike for EPA and is denoted by equation (4) as

$$\alpha_i = \alpha_j \quad \forall \quad 1 \leq i, j \leq N \quad (4)$$

Thus, a single  $\alpha \in R$  can be used to designate the chip amplitudes. The value of  $\alpha$  has been chosen to satisfy  $\alpha^2 N = E_s$ . In the case of EPA, for power normalization the amplitude coefficient is customarily chosen as  $\alpha = \sqrt{1/N}$  to ensure that  $E\{x^2\} = E_s = 1$ . To obtain simple expressions,  $\alpha = 1$  is used for illustration purpose while  $\alpha = \sqrt{1/N}$  for the purpose of performance assessment. The superimposed chips  $c_n$  are independent and identically distributed. The inclusive summation of these chips denoted by  $x$  and is represented in Fig. 1. The cardinality of SM-EPA is defined by  $|X| = N + 1$ . The parameter  $x$  has a Gaussian distribution for large  $N$  as given in Fig 2. The symbol distribution being Gaussian-like, the need of active signal shaping is eliminated. The average amount of information, i.e., the entropy of SM symbols can be obtained [4] by the following equation (5)

$$H(x) \approx \frac{1}{2} \log_2 \left( \frac{\pi}{2} eN \right) \text{ bits/symbol} \quad (5)$$

Equation (5) reflects the major drawback SM-EPA in the sense that that the entropy is expected to be  $H(x) \sim N$  rather than  $H(x) \sim \log_2(N)$ .

Table 1. shows the logarithmic variation of symbol entropy of SM-EPA with bit load  $N$  and the decreasing nature of compression rate  $H(x)/N$  with increasing  $N$ .







**Shibashis Pradhan et al.**

**Unequal Power Allocation (UPA)**

The Unequal Power Allocation scheme is characterized by the exponential law and described by the following equation (6)

$$x = \sum_{n=1}^N c_n = \sum_{n=1}^N a_n a_n, \quad a_n \in \{\pm 1\}$$

with  $a_n = a \cdot \rho^{n-1}$ ,  $0 < \rho < 1$  where  $\rho$  is the exponential base and the value of 'a' should be such that  $E\{x^2\} = E_s$  is fulfilled. The symbol distribution for SM-UPA has been shown in Fig. 3. The above Fig 3. shows that symbol distribution for SM-UPA is bijective for  $\rho < 1$ . Moreover, at  $\rho = 0.5$ , the symbol distribution is uniform and probabilistically equal. The symbol entropy varies linearly with the bit load N.

**Grouped Power Allocation (GPA)**

Grouped Power Allocation is a hybrid of equal and unequal power allocation strategy. It shows the advantages of both EPA and UPA while eliminating the disadvantages. SM-GPA is hereby defined as in equation (7)

$$x = \sum_{l=1}^L a_l \sum_{g=1}^G d_{l,g} \quad \text{where } d_{l,g} \in \{\pm 1\},$$

L gives the number of power levels and G gives the group size and  $N=LG$ . The amplitude co-efficient  $a_l$  of the  $l^{th}$  power level is defined as  $a_l = a \cdot 2^{(l-1)}$  with the value of 'a' chosen to satisfy  $E\{x^2\} = E_s$ . The symbol cardinality of SM-GPA is given as  $|X| = G(2^L - 1) + 1$ . The symbol distribution is uniform for  $G=1$  and thus SM-GPA with such a setup is equivalent to SM-UPA and hence not capacity achieving. For  $G=2$ , a triangular envelope distribution is obtained which is not desirable from capacity achieving viewpoint. Thus increasing the group size by three or more groups results in more Gaussian distribution represented in Fig 4. for  $G=6$  and  $L=2$ . The symbol entropy for SM-GPA for large L is given as

$$H(x) \approx \frac{1}{2} \log_2 \left( \frac{\pi}{8} eG \cdot 2^{2L} \right) \sim \log_2 \left( \frac{\pi}{8} eG \right) + L \text{ bits/symbol}$$

It may be seen that SM-GPA is much more efficient than SM-EPA in terms of supportable bandwidth efficiency, given similar bit loads, N and is illustrated by Table 2.

**SIMULATION RESULTS**

QAM, EPA, UPA AND GPA Simulation results are hereby compared.

**SM-EPA.**

The capacity vs SNR curve for SM-EPA is shown in Figure 5. The curve of QAM system has also been included for comparison. The above results validate that SM-EPA is more capacity achieving compared to QAM, as the capacity curves of EPA approach towards the Gaussian curve without using active signal shaping. Fig. 5 shows that a larger value of N is essential to achieve the similar capacity with regard to QAM mapping. As shown in the figure above at an SNR of 8 dB a capacity of 2 bits/symbol is attained with QAM at N=2 while the same capacity is attained with SM-UPA at N=4. This infers that SM-EPA capacity achieving in regard to QAM at the cost of higher value of N.

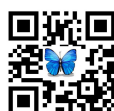

**Shibashis Pradhan et al.****SM-UPA.**

The capacity curves for QAM and SM-UPA for  $\rho = 0.25$  and are demonstrated in Figure 6. With SM-UPA, a higher SNR is vital to achieve the same capacity with respect to QAM. It may be observed from the above figure that with QAM a capacity of 6 bits/symbol is achieved at SNR of 20dB whereas the same capacity is achieved with SM-UPA at an SNR of around 36 dB i.e. at the cost of higher SNR value. Moreover, the capacity curves for SM-UPA for  $\rho = 0.25$  are more deviated from the ideal Gaussian curve as compared to QAM from which we conclude that SM-UPA is not capacity achieving with respect to QAM.

**SM-GPA**

The corresponding capacity curves for SM-GPA have been shown in Fig. 7. It depicts that the capacity curves for SM-GPA method the Gaussian curve for all values of N as compared to QAM. This establishes the capacity achieving nature of SM-GPA. From these analytical results and also from the theoretical results obtained in Table 1 and Table 2 we can conclude that GPA is the most effective power allocation scheme among the three alternatives in terms of its ability to achieve Gaussian channel capacity.

**CONCLUSION**

In this paper, a novel technique of non-bijective mapping called Superposition Modulation has been discussed with specific focus on its diverse power allocation schemes. It has been pointed out that SM is capacity achieving with proper power allocation. Grouped Power Allocation is found to be more suitable when dealt with real-valued signals. SM shows good performance when applied in Bit-Interleaved Coded Modulation (BICM). The work presented in this paper could further extended in conjunction with Orthogonal Frequency Division Multiplexing (OFDM) and also in Multi-Input Multi-Output (MIMO) systems.

**REFERENCES**

1. C. E. Shannon, "A mathematical theory of communication," *Bell System Technical Journal*, vol. 27, pp. 379-423, 623-656, Jul., Oct., 1948.
2. T. M. Cover and J.A. Thomas, *Elements of Information Theory*, John Wiley & Sons, Inc., 1991.
3. L. Duan, B. Rimoldi, and R. Urbanke, "Approaching the AWGN Channel Capacity without Active Shaping," in *ProcIEEE Int'l. Symp. Info. Theory (ISIT'97)*, Ulm, Germany, June/July1997.
4. X. Ma and Li Ping, "Coded modulation using superimposed binary codes," *IEEE Trans. Inf. Theory*, vol. 50, no. 12, pp. 3331-3343, Dec. 2004.
5. Li Ping, "Interleave-division multiple access and chip-by-chip iterative multi-user detection," *IEEE Commun. Mag.*, vol. 43, no. 6, pp. S19-S23, Jun. 2005.
6. Li Ping, L. Liu, K. Wu, and W. K. Leung, "Interleave-division multiple-access," *IEEE Trans. Wireless Commun.*, vol. 5, no. 4, pp. 938-947, Apr. 2006.
7. P. A. Hoeher and T. Wo, "Superposition Modulation : Myths and facts", *IEEE Commun. Mag.*, vol. 49, no. 12, pp.110-116, Dec. 2011
8. Wo, M. Noemm, D. Hao, and P. A. Hoeher, "Iterative processing for Superposition Mapping," *Hindawi Journal of Electrical and Computer Engineering- Special issue on Iterative Signal Processing in Communications*, vol. 2010.
9. T. Wo. and P. A. Hoeher, "Superposition mapping with application in bit-interleaved coded modulation," in *Proc. 8th International ITG Conference on Source and Channel Coding(SCC' 10)*, Siegen, Germany, Jan. 18-21, 2010.





Shibashis Pradhan et al.

Table 1. Symbol Cardinalities, Symbol Entropies and Compression Rates of SM-EPA

N	$ \mathcal{X}  = N + 1$	H(x)	H(x)/ N
4	5	2.03 bits	0.50
8	9	2.54 bits	0.31
12	13	2.83 bits	0.23
16	17	3.04 bits	0.19

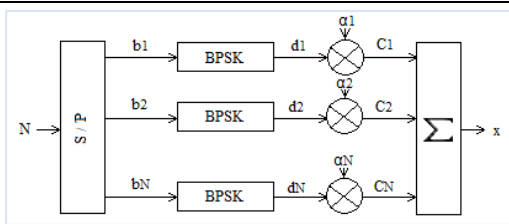

Figure 1. General structure of superposition mapping

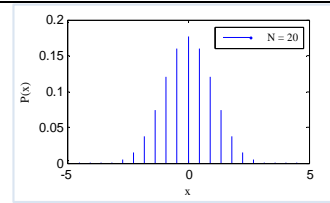

Figure 2. Symbol distribution of SM-EPA,  $E_s = 1$ ,

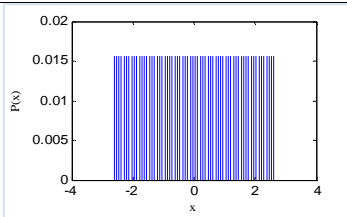

Figure 3. Symbol distribution of SM-UPA,  $q=0.5$ ,  $N=6$ .

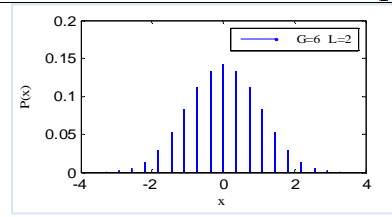
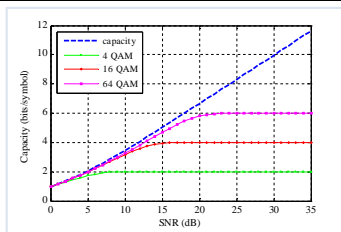
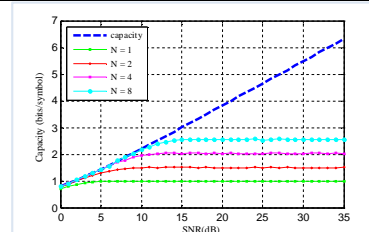

Figure 4. Symbol distribution of SM - GPA,  $E_s = 1$ .



(a) QAM



(b) SM-EPA

Figure 5. Capacity vs. SNR curves

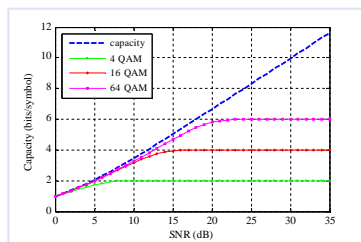

(a) QAM

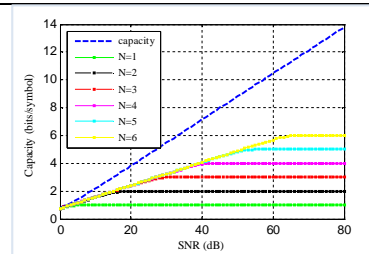

(b) SM-UPA

Figure 6. Capacity vs. SNR curves





**Shibashis Pradhan et al.**

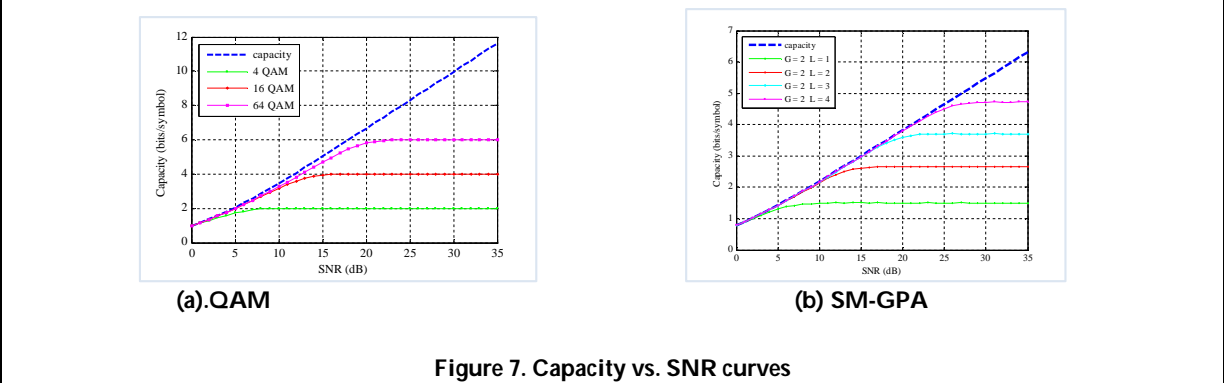

Figure 7. Capacity vs. SNR curves

